

**REPAIR PARTS MANUAL**  
**MODEL NO. 274100**  
**Lawn Tractor**

*16.0 hp Bds 42" Manual gear*

*Rev 6*

**CRAFTSMAN®**

# HOW TO USE THIS MANUAL

This manual is designed to provide the customer with a means to identify the parts on his/her tractor when ordering repair parts. The illustrations may or may not represent the actual assemblies; therefore, it is not recommended to use this manual as a guide to assemble or disassemble the tractor. Some hardware and parts are drawn larger in order to more readily identify them.

Each tractor has its own model number.

The model number for your tractor can be found on the fender under the seat.

When ordering parts, always give the following information:

- Product - "Tractor"
- Model Number - "274100"
- Part Number
- Part Description

## TABLE OF CONTENTS

SCHEMATIC .....	3
ELECTRICAL.....	4-5
CHASSIS.....	6-7
DRIVE.....	8-9
STEERING .....	10-11
ENGINE.....	12
SEAT .....	13
DECALS.....	14
MOWER LIFT .....	15
MOWER DECK .....	16-17
TRANSAXLE.....	18-19
ENGINE BREAKDOWN.....	20-23
WARRANTY.....	24

# TRACTOR- -MODEL NO. 917. 274100

## SCHEMATIC

03059\_197428

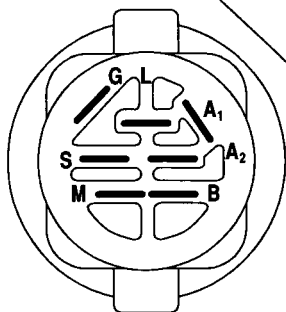
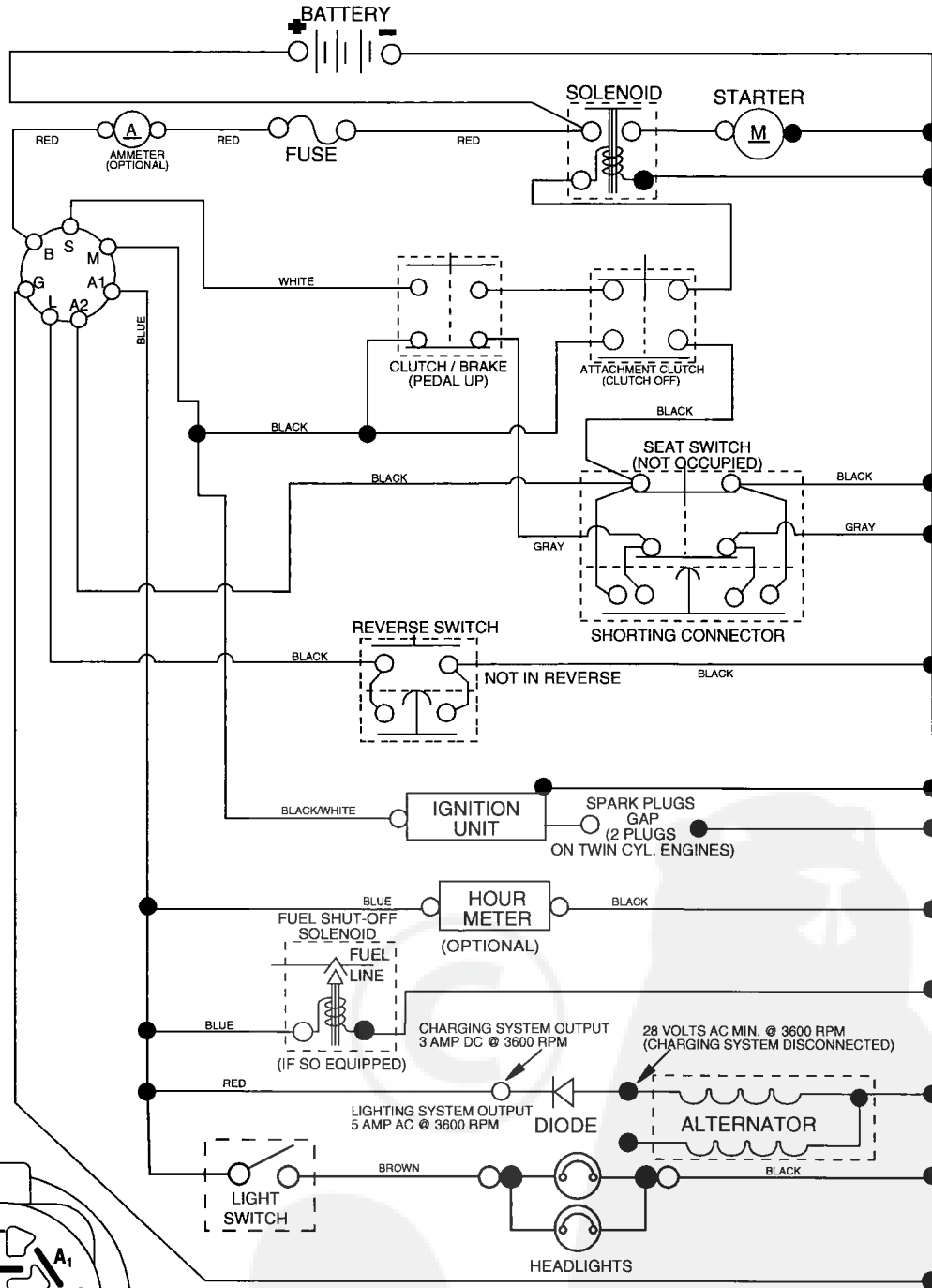

**IGNITION SWITCH**

POSITION	CIRCUIT	"MAKE"
OFF	M+G+A1	
RUN/OVERRIDE	B+A1	
RUN	B+A1	L+A2
START	B + S + A1	

03059

### NOTE

YOUR TRACTOR IS EQUIPPED WITH A SPECIAL ALTERNATOR SYSTEM. THE LIGHTS ARE NOT CONNECTED TO THE BATTERY, BUT HAVE THEIR OWN ELECTRICAL SOURCE. BECAUSE OF THIS, THE BRIGHTNESS OF THE LIGHTS WILL CHANGE WITH ENGINE SPEED. AT IDLE THE LIGHTS WILL DIM. AS THE ENGINE IS SPEEDED UP, THE LIGHTS WILL BECOME THEIR BRIGHTEST.

NON-REMOVABLE CONNECTIONS

REMOVABLE CONNECTIONS

### WIRING INSULATED CLIPS

**NOTE:** IF WIRING INSULATED CLIPS WERE REMOVED FOR SERVICING OF UNIT, THEY SHOULD BE REPLACED TO PROPERLY SECURE YOUR WIRING.

# REPAIR PARTS

TRACTOR- -MODEL NO. 917. 274100

## ELECTRICAL

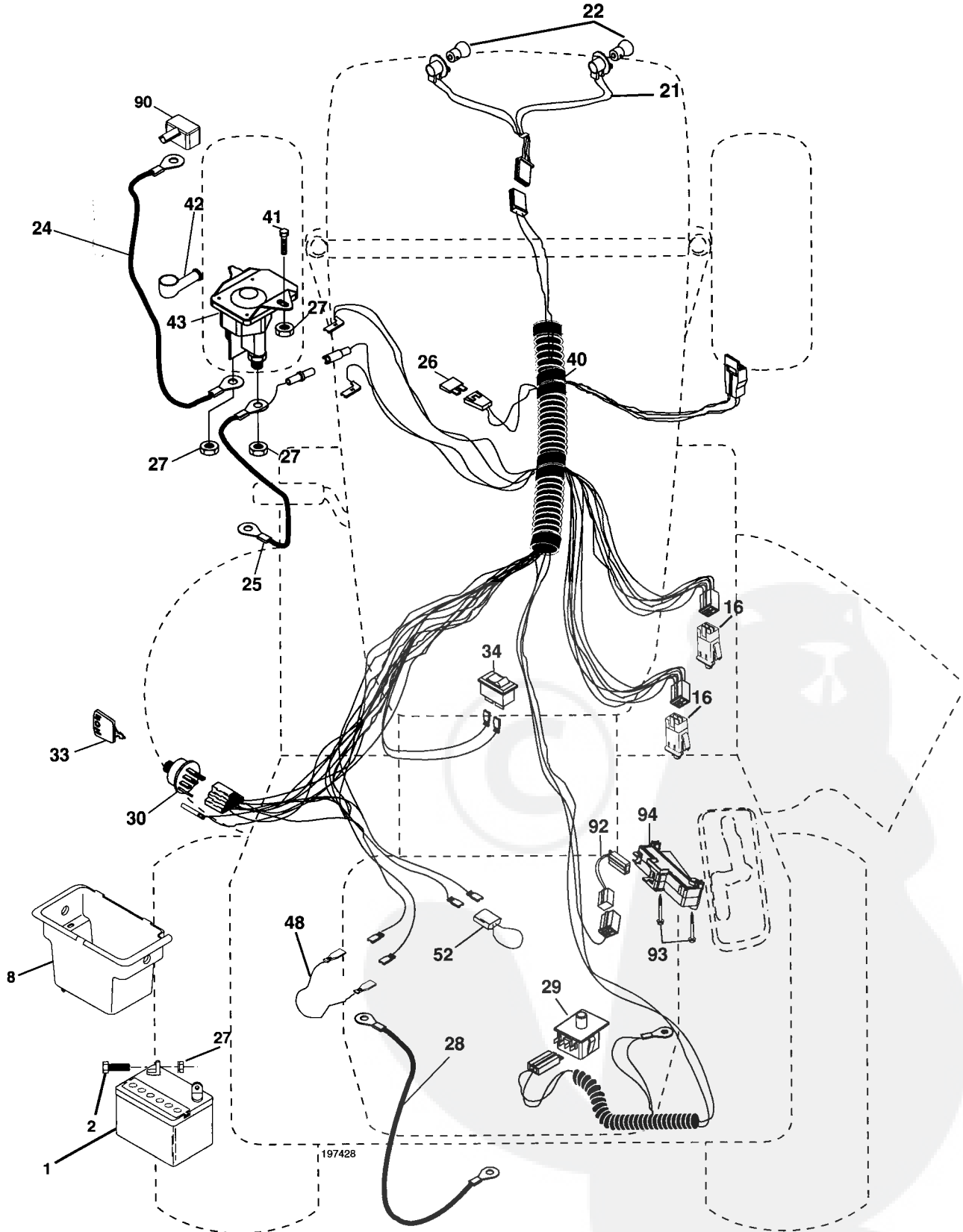

# REPAIR PARTS

## TRACTOR- -MODEL NO. 917. 274100

### ELECTRICAL

KEY NO.	PART NO.	DESCRIPTION
1	163465	Battery
2	74760412	Bolt Hex Hd 1/4-20 unc x 3/4
8	176689	Box Battery Fender
16	176138	Switch, Interlock
21	183759	Harness Asm Light W/4152j
22	4152J	Bulb Light #1156
24	4799J	Cable Battery 6 Ga. 11" red
25	146147	Cable Battery 6 Ga. w/16 wire red
26	175158	Fuse 20 AMP
27	73510400	Nut, Keps Hex 1/4-20 unc
28	4207J	Cable Ground 6 Ga. 12" black
29	192749	Switch Seat
30	193350	Switch Ign
33	140403	Key Ign Molded Craftsman
34	110712X	Switch Light
40	197428	Harness Ign
41	71110408	Bolt Blk. Fin Hex 1/4-20 unc x 1/2
42	131563	Cover Terminal Red
43	192507	Solenoid
48	140844	Adapter Ammeter
52	141940	Protection Wire Loop
90	180449	Cover Battery Terminal
92	196615	Harness Pigtail
93	192540	Screw Plastic 10-14 x 2.0
94	191834	Module Reverse ROS

**NOTE:** All component dimensions give in U.S. inches  
1 inch = 25.4 mm

# REPAIR PARTS

## TRACTOR- -MODEL NO. 917. 274100

### CHASSIS AND ENCLOSURES

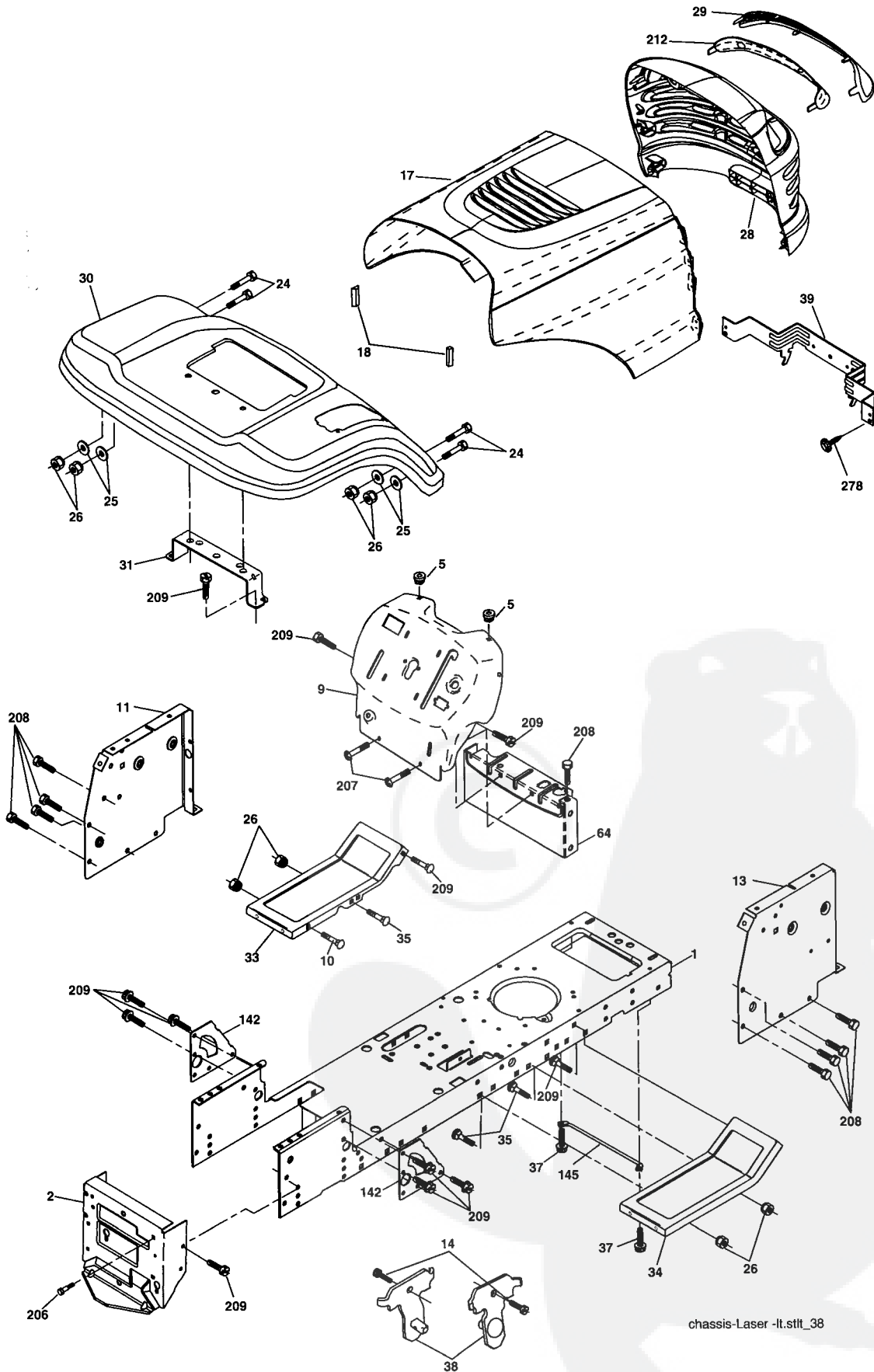

chassis-Laser-It.stlt\_38

# REPAIR PARTS

## TRACTOR- -MODEL NO. 917. 274100

### CHASSIS AND ENCLOSURES

KEY NO.	PART NO.	DESCRIPTION
1	174619	Chassis Stamping
2	176554	Drawbar
5	155272	Bumper Hood/Dash
9	193510X013	Dash
10	STD533710	Bolt, Carriage 3/8-16 x 1
11	174996	Panel, Dash, L.H.
13	172105X010	Panel, Dash, R.H.
14	17490608	Screw Thdrol 3/8-16 x 1/2
17	185682X613	Hood Assembly Laser
18	184921	Bumper Hood Large 1.75
24	STD523710	Bolt Fin Hex 3/8-16 unc x 1 Gr. 5
25	19131312	Washer 13/32 x 13/16 x 12 Ga.
26	STD541437	Nut
28	193258	Grille Lens Asm Laser (Includes Key Nos. 29 and 212)
29	174332X599	Lens, Laser
30	192526X613	Fend/Ftrest Pnt STLT
31	136619	Bracket, Fender Support
33	179716X613	Footrest LH
34	179717X613	Footrest RH
35	STD533707	Bolt Rdhd Sht Sqnk 3/8-16 x 3/4
37	17490508	Screw Thdrol 5/16-18 x 1/2 Tyt
38	175710	Bracket Asm. Pivot Mower Rear
39	174714	Bracket Pivot Laser
64	154798	Dash Lower
142	175702	Plate Reinforcement
145	156524	Rod Pivot Chassis/Hood
206	170165	Bolt Shoulder 5/16 -18 TT
207	17670508	Screw 5/16-18 x 1/2
208	17670608	Screw Thdrol 3/8-16 x 1/2
209	17000612	Screw Hex Wsh Thdr 3/8-16 x 3/4
212	175143	Insert Lens Reflective
278	191611	Screw 10 x 3/4 Single Head-Hex
--	5479J	Plug, Button

**NOTE:** All component dimensions given in U.S. inches  
1 inch = 25.4 mm

# REPAIR PARTS

## TRACTOR- -MODEL NO. 917. 274100

### DRIVE

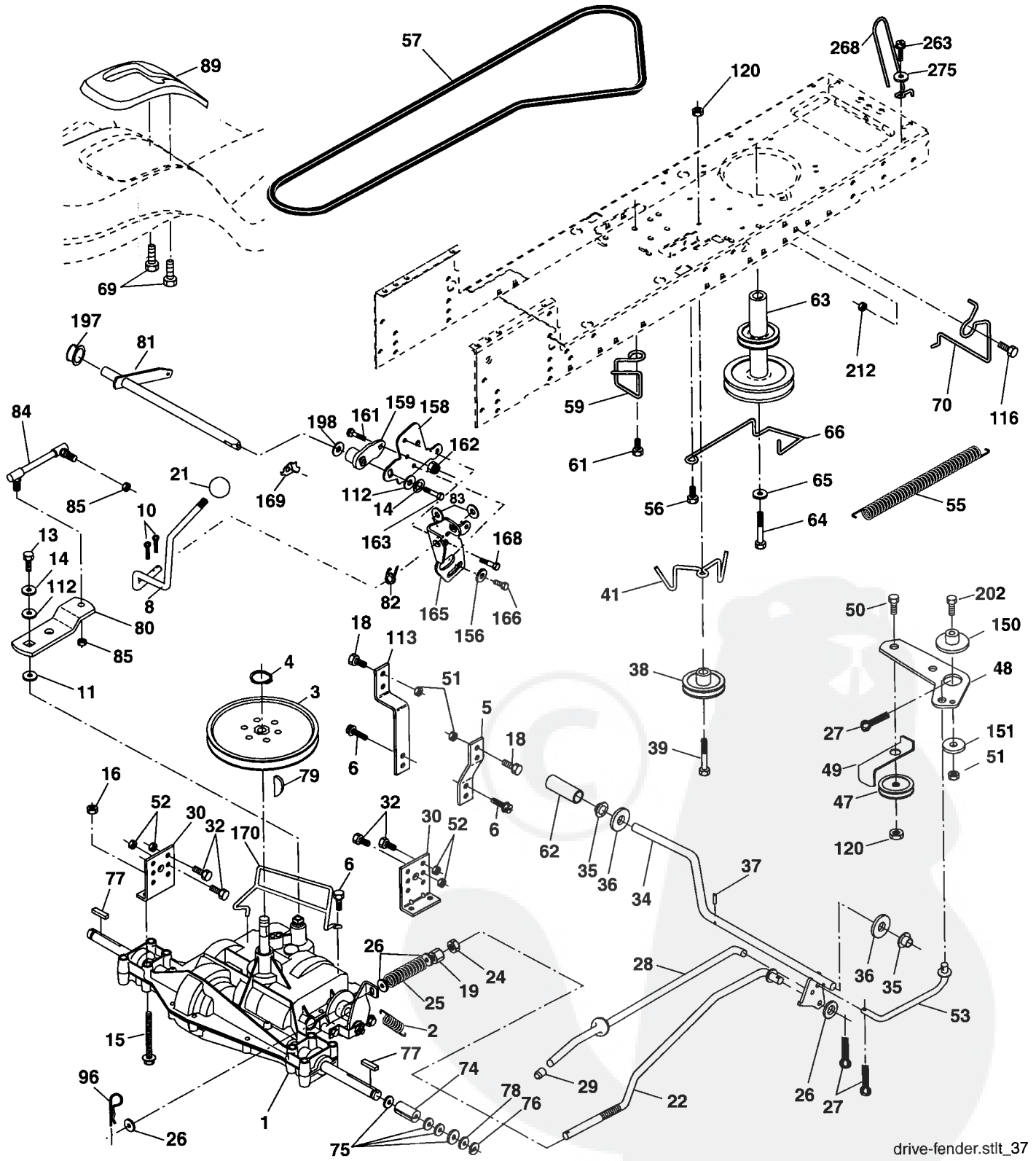

drive-fender.stlt\_37



# REPAIR PARTS

## TRACTOR- -MODEL NO. 917. 274100

### DRIVE

KEY NO.	PART NO.	DESCRIPTION	KEY NO.	PART NO.	DESCRIPTION
1	-----	Transaxle Dana D4360-139 (See Breakdown)	64	173937	Bolt Hex 7/16-20 x 4 Gr. 5-1.5
2	146682	Spring Brake Return	65	STD551143	Washer
3	123666X	Pulley Transaxle	66	154778	Keeper Belt Engine Hydro
4	12000028	Ring Retainer	69	142432	Screw Hex Wsh Hi-Lo 1/4 x 1/2 unc
5	121520X	Strap Torque 30 Degrees	70	180218	Guide Belt Mower
6	17000512	Screw 5/16-18 x 3/4	74	109502X	Spacer
8	192706	Rod Shift Fender Adjust	75	121749X	Washer 25/32 x 1-1/4 x 16 Ga.
10	STD561210	Pin Cotter 1/8 x 1 CAD	76	STD581075	E-Ring
11	105701X	Washer Plate Shift	77	123583X	Key, Square
13	74550412	Bolt 1/4-28 unf Gr. 8 W/Patch	78	121748X	Washer 25/32 x 1-5/8 x 16 Ga.
14	10040400	Washer Lock Hvy Helical	79	2228M	Key Woodruff
15	74490544	Bolt Hex FLGHD 5/16-18 x Gr. 5	80	131488	Arm Shift
16	STD541431	Nut Lock Hex W/Ins. 5/16-18 unc	81	165594	Shaft Asm Cross Tapered
18	74780616	Bolt Fin Hex 3/8-16 x 1 Gr. 5	82	165711	Spring Torsion
19	STD541437	Nut Lock Hex W/Wsh 3/8-16 unc	83	19171216	Washer 17/32 x 3/4 x 16 Ga.
21	106933X	Knob	84	166229	Link Transaxle
22	130804	Rod, Brake	85	150360	Nut Lock Center 1/4-20
24	73350600	Nut, Hex Jam 3/8-16 unc	89	192054X428	Console, Shift
25	106888X	Spring, Brake Rod	96	4497H	Retainer Spring 1" Zinc/Cad
26	STD551037	Washer 13/32 x 13/16 Ga.	112	19091210	Washer 9/32 x 3/4 x 10 Ga.
27	STD561210	Pin Cotter 1/8 x 3/4 CAD.	113	127285X	Strap Torque 90 Degrees
28	175765	Rod, Parking Brake	116	72140608	Bolt Rdhd Sqneck 3/8-16 x 1.25
29	71673	Cap, Parking Brake	120	73900600	Nut Lock Flg 3/8-16
30	174973	Bracket, Transaxle	150	175456	Spacer Retainer
32	74760512	Bolt Hex Hd 5/16-18 unc x 3/4	151	19133210	Washer 13/32 x 2 x 10 Ga.
34	175578	Shaft, Foot Pedal	156	166002	Washer Srrted 5/16 ID x 1.125
35	120183X	Bearing, Nylon	158	165589	Bracket Shift Mount
36	19211616	Washer	159	183900	Hub Shift
37	1572H	Pin, Roll	161	72140406	Bolt Rdhd Sqnk 1/4-20 x 3/4 Gr. 5
38	179114	Pulley, Composite, Flat	162	73680400	Nut Crownlock 1/4-20 unc
39	72110622	Bolt Fin Hex 3/8-16 x 2-3/4	163	74780416	Bolt Hex Fin 1/4-20 unc x 1 Gr. 5
41	175556	Keeper, Belt Idler	165	165623	Bracket Pivot Lever
47	127783	Pulley, Idler, V-Groove	166	17490510	Screw 5/16-18 x 5/8
48	154407	Bellcrank, Clutch	168	165492	Bolt Shoulder 5/16-18 x .561
49	123205X	Retainer, Belt	169	165580	Plate Fastening
50	72110612	Bolt Carr 3/8-16 x 1-1/2	170	187414	Keeper Belt T/A
51	STD541437	Nut Crownlock 3/8-16 unc	197	169613	Nyliner Snap-In 5/8"ID
52	STD541431	Nut, Crownlock 5/16-18 unc	198	169593	Washer Nyl
53	199652	Link, Clutch	202	72110614	Bolt Carr Sh 3/8-16 x 1-3/4 Gr. 5
55	105709X	Spring, Return, Clutch	212	145212	Nut Hex Flg. Lock
56	17060620	Screw 3/8-16 x 1-1/4	263	17000612	Screw 3/8-16 x 3/4
57	160855	V-Belt	268	182402	Guard Muffler
59	169691	Keeper, Center Span	275	19131614	Washer 13/32 x 1 x 14 Ga.
61	17120614	Screw, 3/8-16 x .875			
62	8883R	Cover, Pedal			
63	180219	Pulley, Engine			

**NOTE:** All component dimensions give in U.S. inches  
1 inch = 25.4 mm

# REPAIR PARTS

TRACTOR- -MODEL NO. 917. 274100

## STEERING ASSEMBLY

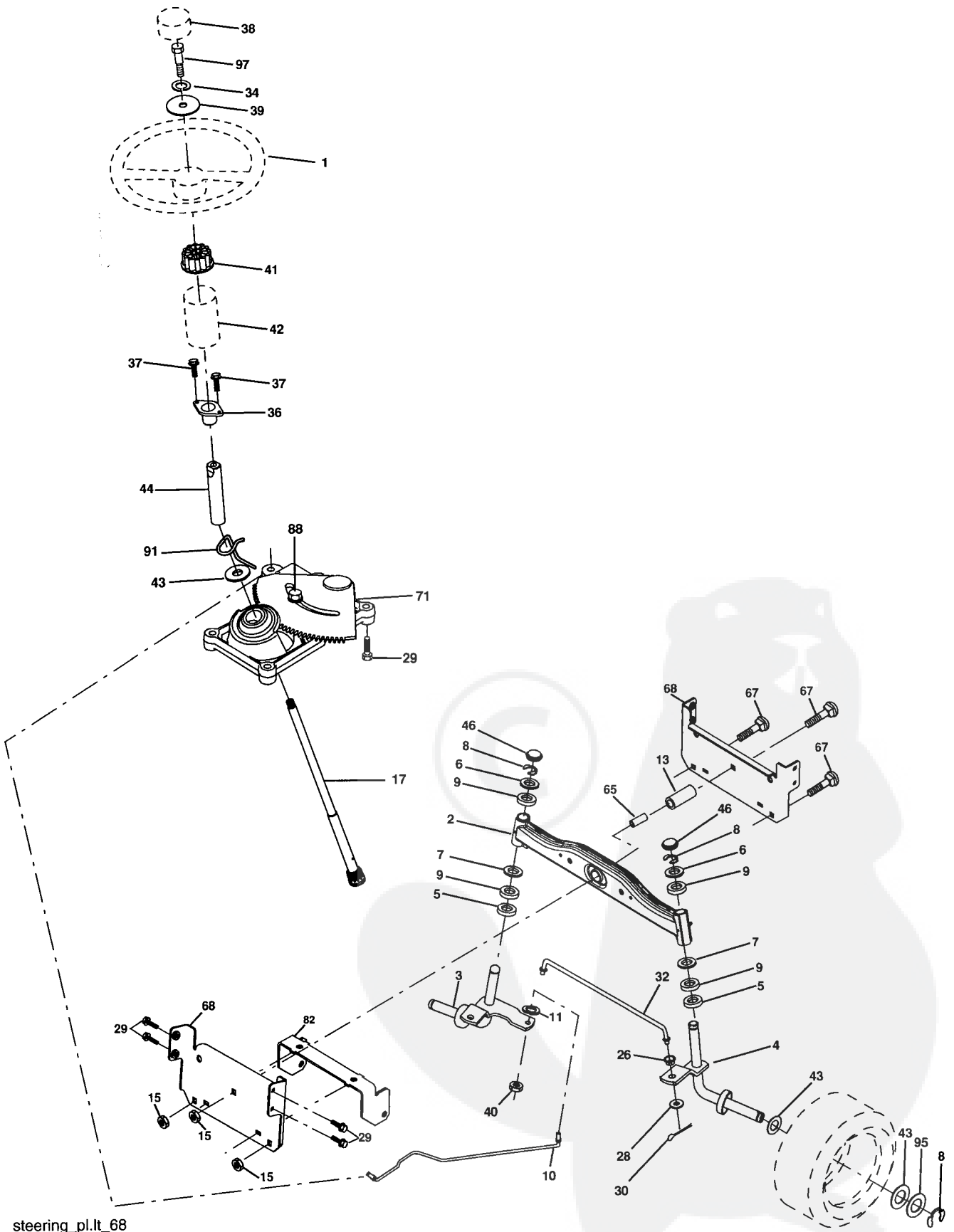

steering\_pl.it\_68

# REPAIR PARTS

## TRACTOR- -MODEL NO. 917. 274100

### STEERING ASSEMBLY

KEY NO.	PART NO.	DESCRIPTION
1	186780	Steering Wheel
2	195673	Axle Assembly
3	169840	Spindle Assembly, L.H.
4	169839	Spindle Assembly, R.H.
5	6266H	Bearing, Race, Thrust, Hardened
6	121748X	Washer 27/32 x 1-1-1/4 x 16 Ga.
7	19272016	Washer 25/32 x 1-1/2 x 14 Ga.
8	12000029	Ring, Klip
9	3366R	Bearing Col. Strg.
10	175121	Draglink
11	STD551137	Washer, Lock
13	136518	Spacer Brg Axle Front
15	145212	Nut, Hexflange Lock
17	190753	Shaft, Steering
26	126847X	Bushing, Link, Drag
28	19131416	Washer 13/32 x 7/8 x 16 Ga.
29	17000612	Screw 3/8-16 x 3/4
30	STD561210	Pin
32	192757	Rod, Tie
34	10040500	Washer Lock Hvy Hlcl Spr. 5/16
36	155099	Bushing, Steering
37	152927	Screw
38	186781	Insert, Steering Wheel
39	19113812	Washer 11/32 x 2-3/8 x 12 Ga.
40	73540600	Nut Crownlock 3/8-24
41	186737	Adaptor, Steering Wheel
42	145054x428	Boot, Steering Shaft
43	121749X	Washer 25/32 x 1-1/4 x 16 Ga.
44	190752	Extension Shaft Steering
46	121232X	Cap, Spindle
65	160367	Spacer Brace Axle
67	72110618	Bolt Rdhd Sqnk 3/8-16 x 2-1/4
68	169827	Axle, Brace
71	175146	Steering Asm
82	199978	Bracket Susp Chassis Front
88	175118	Bolt Shoulder 7/16-20
91	175553	Clip Steering
95	188967	Washer Hardened .793 x 1.637 x .060
97	74780564	Bolt 5/16-18 unc x 4 Gr. 5

**NOTE:** All component dimensions given in U.S. inches  
1 inch = 25.4 mm

# REPAIR PARTS

## TRACTOR- -MODEL NO. 917. 274100

### ENGINE

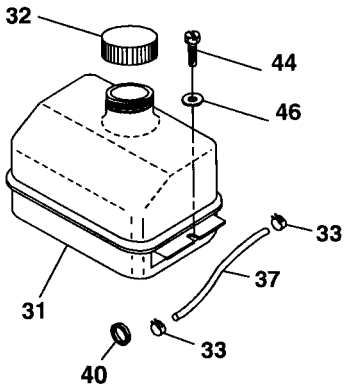
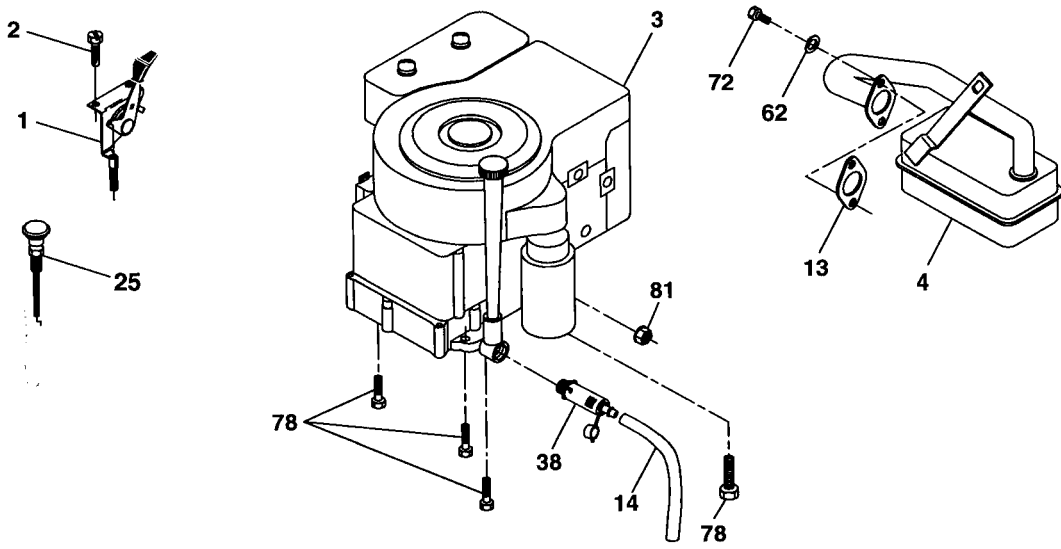

29  
**OPTIONAL EQUIPMENT**  
**Spark Arrester**

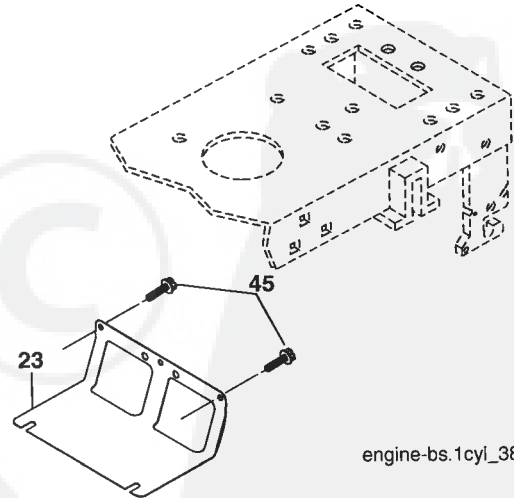

engine-bs.1cyl\_38

KEY NO.	PART NO.	DESCRIPTION
1	170545	Control, Throttle/Choke
2	17720408	Screw, Hex Head, Thread Cutting 1/4-20 x 1/2
3	-----	Engine, Briggs Model No. 283H07-0400-B1
4	137352	Muffler
13	165291	Gasket
14	148456	Tube Drain Oil Easy
23	169837	Shield Brn/Dbr Guard
25	187770X428	Control Choke
29	137180	Arrester, Spark
31	187750	Tank, Fuel
32	197725	Cap Assembly, Fuel
33	123487X	Clamp, Hose

KEY NO.	PART NO.	DESCRIPTION
37	137040	Line, Fuel
38	181654	Plug, Drain Oil Easy
40	124028X	Bushing Snap
44	17670412	Screw, Hex Washer Head, Thd., Roll. 1/4-20 x 3/4
45	17000612	Screw Hex Wsh Thdr 3/8-16 x 3/4
46	19091416	Washer 9/32 x 7/8 x 16 Ga.
62	10010500	Washer Split
72	192334	Screw Socket 5/16-18 x.75
78	17060620	Screw 3/8-16 x 1-1/4
81	73510400	Nut Keps Hex 1/4-20 unc

**NOTE:** All component dimensions given in U.S. inches 1 inch = 25.4 mm

# REPAIR PARTS

TRACTOR- -MODEL NO. 917. 274100

## SEAT ASSEMBLY

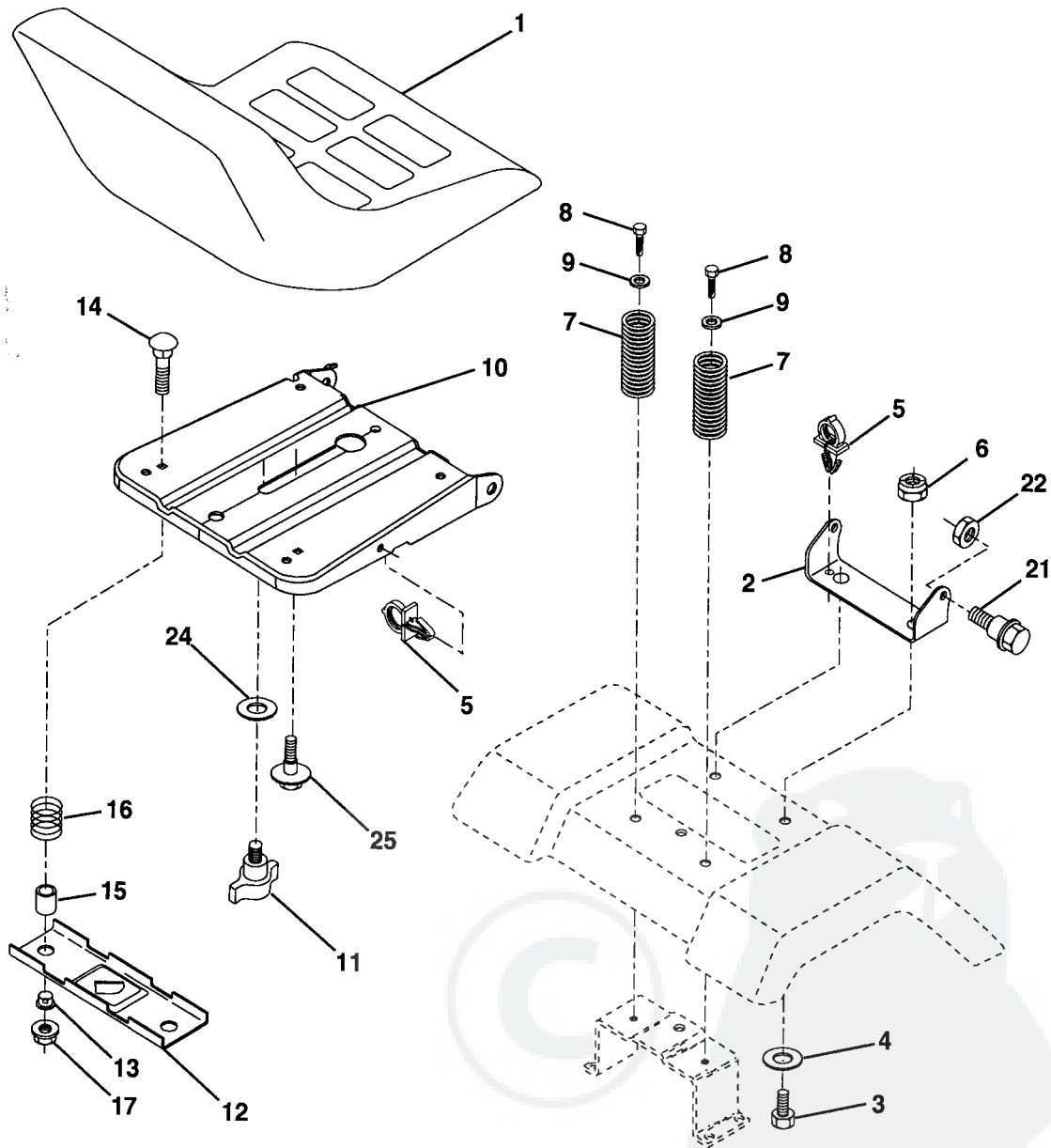

seat\_ft.knob\_13

KEY NO.	PART NO.	DESCRIPTION
1	188709	Seat
2	140551	Bracket, Pivot, Seat
3	71110616	Bolt
4	19131610	Washer 13/32 x 1 x 10 Ga.
5	145006	Clip, Push-In Hinged
6	STD541437	Nut
7	124181X	Spring, Seat
8	17000616	Screw 3/8-16 x 1-1/2
9	19131614	Washer 13/32 x 1 x 14 Ga.
10	195530	Pan, Seat
11	166369	Knob Seat
12	174648	Bracket, Switch Mounting

KEY NO.	PART NO.	DESCRIPTION
13	121248X	Bushing, Snap
14	72050412	Bolt, Carriage 1/4-20 x 1-1/2
15	134300	Spacer, Split .28 x .88
16	121250X	Spring
17	123976X	Locknut, Flange 1/4 Gr. 5
21	171852	Bolt, Shoulder 5/16-18 unc
22	STD541431	Nut
24	19171912	Washer 17/32 x 1-3/16 x 12 Ga.
25	127018X	Washer 17/32 x 1-3/16 x 12 Ga.

**NOTE:** All component dimensions given in U.S. inches  
1 inch = 25.4 mm

# REPAIR PARTS

TRACTOR- -MODEL NO. 917. 274100

## DECALS

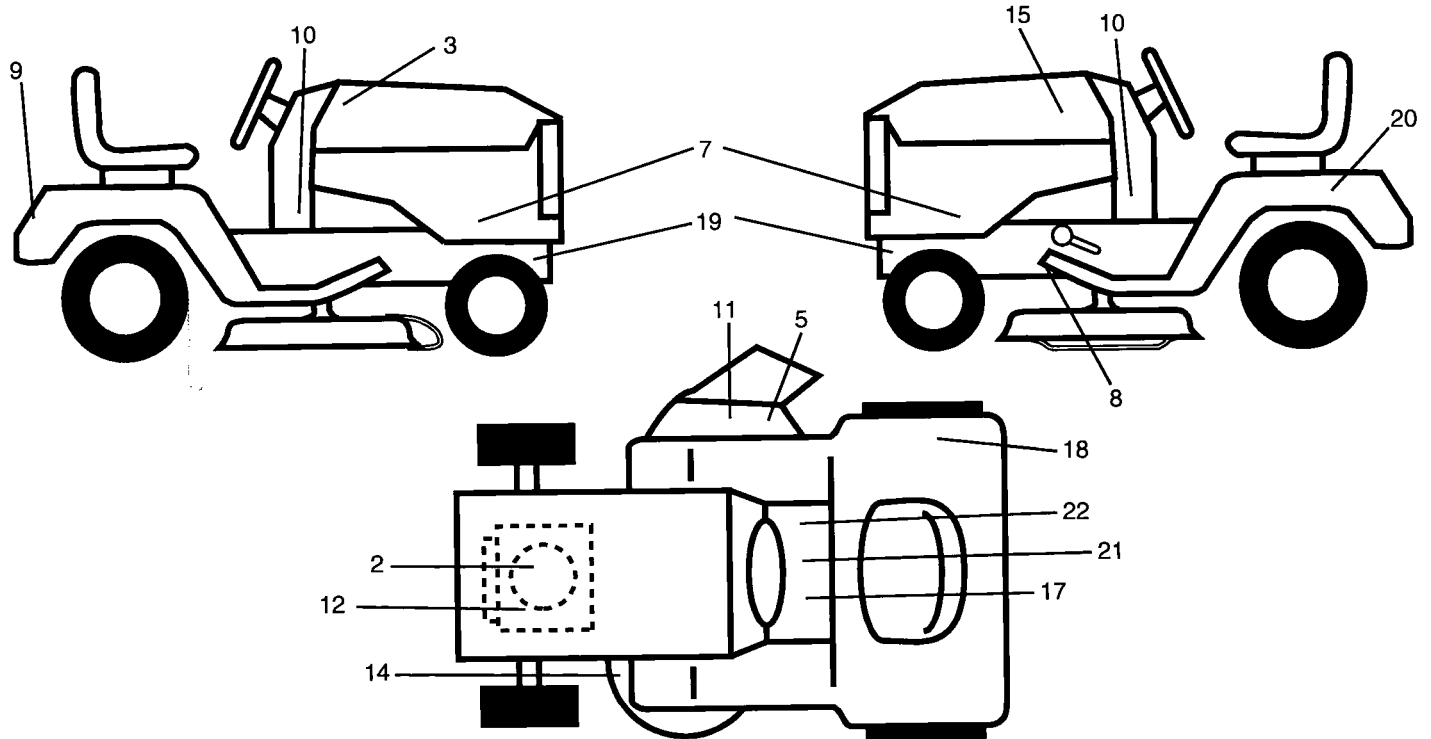

KEY NO.	PART NO.	DESCRIPTION
2	198046	Decal, HP Engine
3	401124	Decal, Hood RH
5	196357	Decal, Warning
7	401126	Decal, Hood Side
8	197490	Decal, V-Belt Schematic
9	401127	Decal, Fender Craftsman
10	189276	Decal, Chassis
11	182166	Decal, Cutfinger CE
12	196841	Decal, Warning. Sym.
14	160396	Decal, V-Belt Schematic
15	401125	Decal, Hood LH
17	400389	Decal, Warning Sym. CE
18	180432	Decal, Fender DB/CE

KEY NO.	PART NO.	DESCRIPTION
19	159736	Decal, Hot Muffler
20	145005	Decal, Battery Dngr/Psn Eng
21	159737	Decal, Brake/Clutch Sym
22	140837	Decal, Saddle Brake/Parking
--	138311	Decal, Lift Handle
--	162598	Decal, Load Limit
--	179768X428	Pad Footrest LH
--	179769X428	Pad Footrest RH
--	404706	Manual, Operator's (Euro)
--	404707	Manual, Operator's (Scan)
--	404708	Manual, Operator's (E-Bloc)
--	404709	Manual, Operator's (Baltic)
--	404710	Manual, Parts

## WHEELS & TIRES

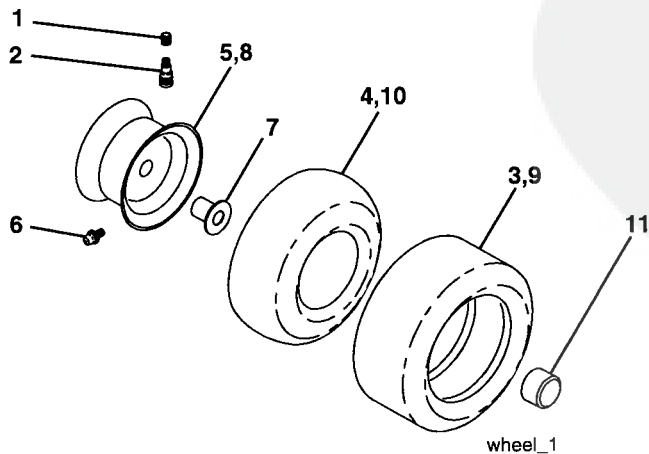

KEY NO.	PART NO.	DESCRIPTION
1	59192	Valve Cap, Tire
2	65139	Stem, Valve
3	106222X	Tire, Front
4	59904	Tube, Front Tire (Not Provided, Service Item Only)
5	106732X624	Rim, Front
6	278H	Fitting, Grease (Front Wheel Only)
7	9040H	Bearing, Flange (Front Wheel Only)
8	106108X624	Rim, Rear
9	106268X	Tire, Rear
10	7152J	Tube, Rear Tire (Not Provided, Service Item Only)
11	104757X428	Cap, Axle
--	144334	Sealant, Tire 10 oz.

**NOTE:** All component dimensions given in U.S. inches  
1 inch = 25.4 mm

# REPAIR PARTS

TRACTOR- -MODEL NO. 917. 274100

## MOWER LIFT

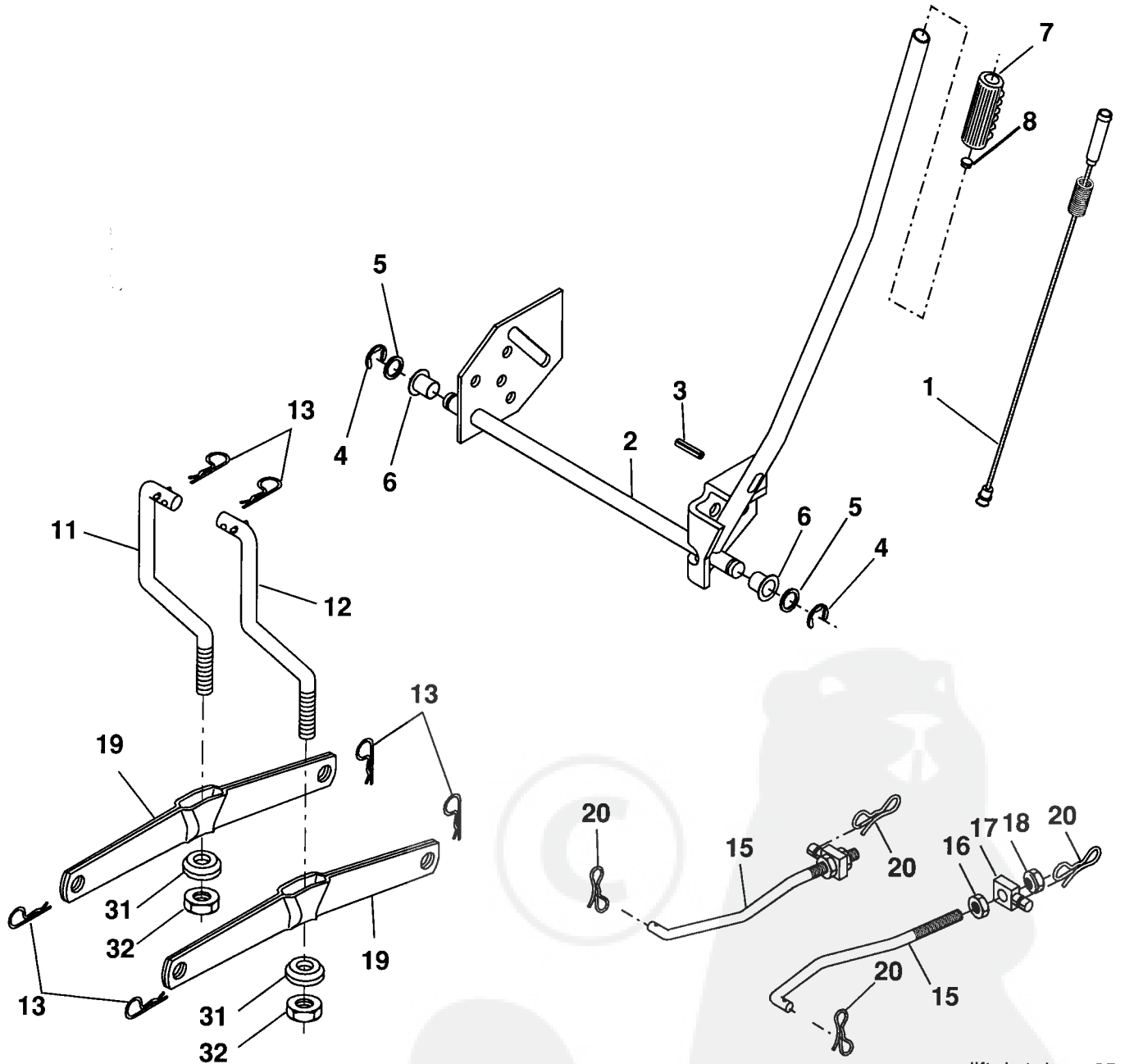

lift-rh.1piece\_25

KEY NO.	PART NO.	DESCRIPTION
1	159460	Lift Lever Inner Wire Assembly
2	159471	Shaft Assembly, Lift
3	105767X	Pin, Groove
4	12000002	E-Ring
5	19211621	Washer 21/32 x 1 x 21 Ga.
6	120183X	Bearing, Nylon
7	125631X	Grip, Handle, Fluted
8	122365X	Button, Plunger, Red
11	139865	Link, Lift, L.H.
12	139866	Link, Lift, R.H.
13	STD624008	Retainer Spring

KEY NO.	PART NO.	DESCRIPTION
15	173288	Link, Front
16	73350800	Nut, Hex, Jam 1/2-13 unc
17	175689	Trunnion
18	73800800	Locknut, Hex, with Washer Insert 1/2-13 unc
19	139868	Arm, Suspension, Rear
20	194209	Pin Cotter 7/16 Bow Tie Lock
31	169865	Bearing, Pvt, Lift
32	73540600	Nut, Crownlock 3/8-24

**NOTE:** All component dimensions given in U.S. inches  
1 inch = 25.4 mm



# REPAIR PARTS

TRACTOR- -MODEL NO. 917. 274100

MOWER

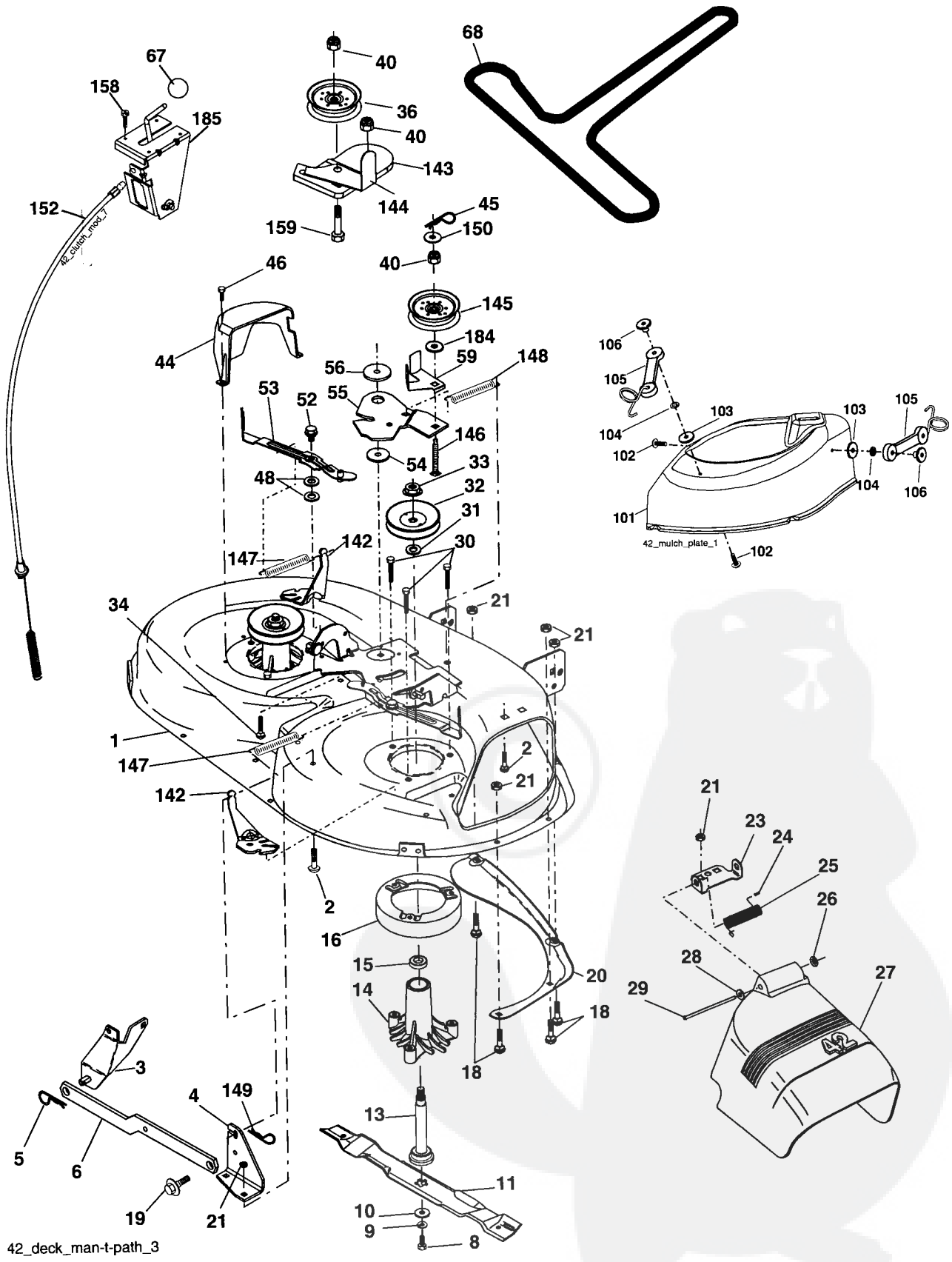

42\_deck\_man-t-path\_3



# REPAIR PARTS

## TRACTOR- -MODEL NO. 917. 274100

### MOWER

KEY NO.	PART NO.	DESCRIPTION	KEY NO.	PART NO.	DESCRIPTION
1	165892	Mower Housing Assembly	52	139888	Bolt Shld 5/16-18
2	72140506	Bolt Carriage 5/16-18 x 3/4	53	184907	Arm. Asm. Brake
3	138017	Bracket Asm Fr. Sway Bar	54	178515	Washer Flat Hardened
4	165460	Bracket Deck Sway Bar	55	155046	Idler Arm Assembly
5	STD624008	Retainer Spring	56	165723	Spacer, Retainer
6	178024	Bar Sway Deck	59	141043	Guard Tuv Idler
8	850857	Bolt 3/8-24 x 1.25 Gr. 8	67	149846	Knob
9	10030600	Washer Lock Hvy 3/8	68	180215	V-Belt
10	140296	Washer Hard Blade Mower	101	193107	Cover Mulching
11	134149	Blade Mower	102	71081010	Screw Pan Hd Phillip 10-24 x 5/8
13	137645	Shaft Assembly	103	19061216	Washer #10
14	128774	Housing, Mandrel, Vented	104	10071000	Washer Lock #10
15	110485X	Bearing, Ball, Mandrel	105	160793	Latch Asm.
16	174493	Stripper Mandrel Deck	106	2029J	Nut Weld .327/.304 #10-24
18	72140505	Bolt Rdhd Sqnc 5/16-18 x 5/8	142	165890	Arm Spring
19	132827	Bolt, Shoulder	143	157109	Bracket Arm Idler
20	159770	Baffle Vortex	144	158634	Keeper Belt
21	73680500	Nut	145	165888	Pulley Idler Flat
23	177563	Bracket, Mower Deflector	146	171977	Bolt Carriage Idler
24	105304X	Cap, Sleeve	147	179748	Spring Extension
25	123713X	Spring, Torsion, Deflector	148	169022	Spring Return Idler
26	110452X	Nut, Push	149	165898	Retainer Spring Yellow
27	130968X428	Shield, Deflector	150	19091210	Washer 9/32 x 3/4 x 10 Ga.
28	19111016	Washer 11/32 x 5/8 x 16 Ga.	152	181555	Clutch Cable
29	131491	Rod, Hinge	158	17720408	Screw Hex Thd Cut 1/4-20 x 1/2
30	173984	Screw Thdrol.	159	72140614	Bolt Rdhd Sqn 3/8-16 unc x 1-3/4
31	187690	Washer, Spacer	184	19131410	Washer 13/32 x 7/8 x 10 Ga.
32	153535	Pulley, Mandrel	185	188234	Head Asm Cable Clutch
33	400234	Nut, Toplock	--	130794	Mandrel Assembly (Includes Housing, Shaft and Shaft Hardware Only - Pulley Not Included)
34	72110612	Bolt Carr. Sh 3/8-16 x 1-1/2 Gr. 5	--	181268	Replacement Mower, Complete
36	131494	Pulley, Idler, Flat			
40	73900600	Nut Lock Flg 3/8-16 unc			
44	140088	Guard Mandrel LH			
45	STD624003	Retainer			
46	137729	Screw Thd Roll 1/4-20 x 5/8			
48	133944	Washer Hardened			

**NOTE:** All component dimensions given in U.S. inches  
1 inch = 25.4 mm

# REPAIR PARTS

TRACTOR- -MODEL NO. 917. 274100

DANA TRANSAXLE - MODEL NUMBER D4360-139

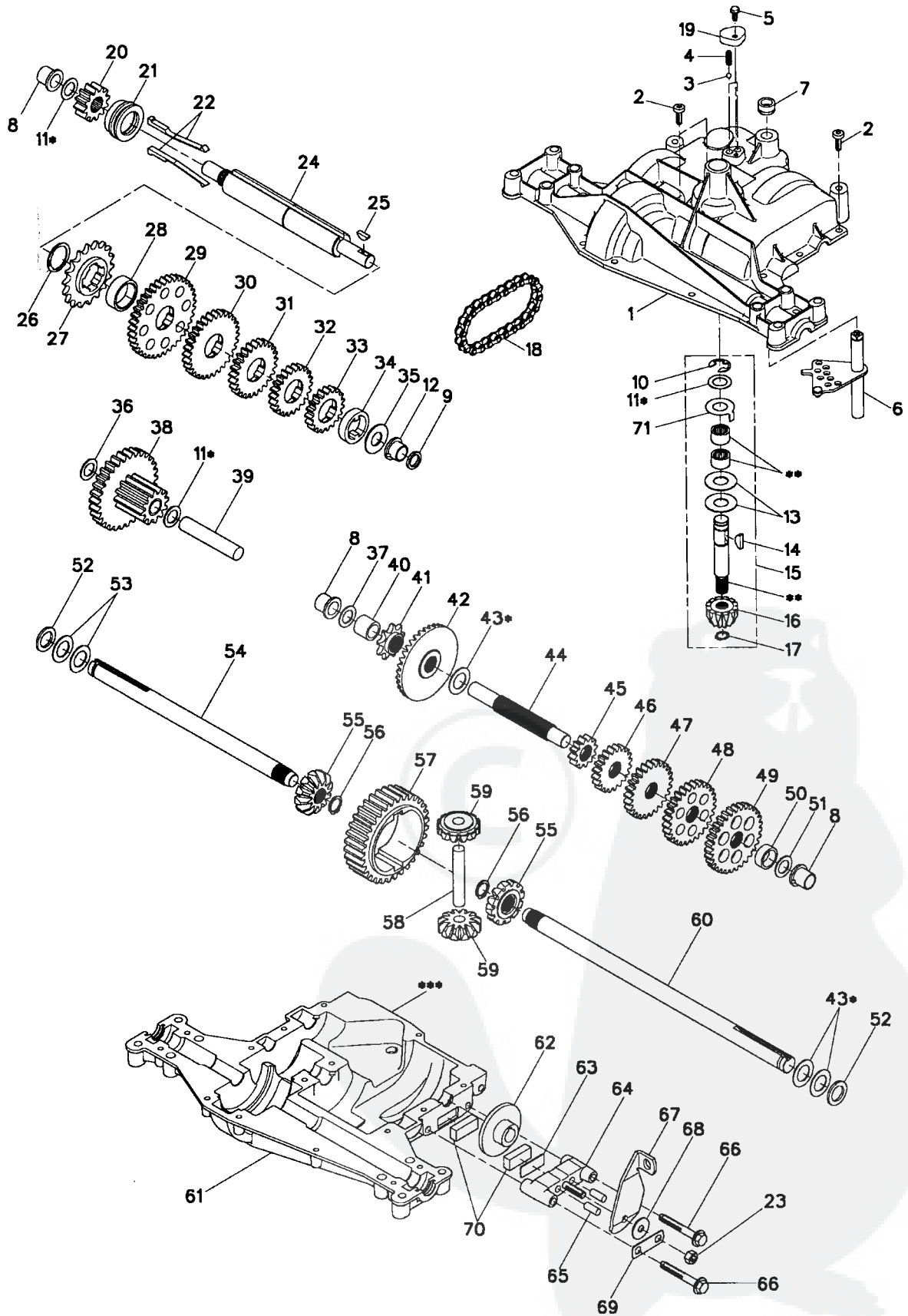

# REPAIR PARTS

## TRACTOR- -MODEL NO. 917. 274100

### DANA TRANSAXLE - MODEL NUMBER D4360-139

KEY NO.	PART NO.	DESCRIPTION	KEY NO.	PART NO.	DESCRIPTION
1	170981	Housing, Upper	41	105928X	Sprocket, 9T
2	2274J	Screw, Tapping, 1/4-20 X .734	42	170988	Gear, Bevel, 36T
3	134400	Ball, Detent	43	134394	* Assy, Kit, Shim, .750 Shaft
4	105904X	Spring, Detent	44	120473X	Shaft, Drive
5	160940	Screw, Tapping, No. 10-24 X .482	45	142678	Gear, Spur, 12T
6	138235	Assy, Kit, Shifter	46	124641 X	Gear, Spur, 20T
7	108727X	V-Ring	47	106589X	Gear, Spur, 25T
8	148266	Bearing, Flange	48	120408X	Gear, Spur, 28T
9	148269	Seal, Oil	49	105937X	Gear, Spur, 31T
10	2225J	Ring, Retaining	50	105936X	Spacer, .781 X 1.00 X .375
11	134793	* Assy, Kit, Shim, .625 Shaft	51	2226J	Washer, Plain, .632 X 1.00 X .060
12	148268	Bearing, Flange	52	134401	Washer, Neoprene
13	120415X	Washer, Plain, .632 X 1.38 X .046	53	2264J	Washer, Plain, .758 X 1.25 X .031
14	142674	Key, Woodruff, No. 9	54	160946	Axle, LH
15	170983	Assy, Kit, Input Shaft	55	170990	Gear, Miter, T, Splined
16	170986	Pinion, Bevel, 12T	56	160948	Ring, Retaining
17	105909X	Ring, Retaining	57	110071X	Gear, Spur, 32T
18	105910X	Chain, 24 Pitches	58	120952X	Shaft, Cross
19	160942	Cover, Detent	59	170991	Gear, Miter, 1 2T, Idler
20	160943	Gear, Spur, 1 2T	60	160950	Axle, RH
21	148267	Collar, Clutch	61	170992	Housing, Lower
22	138236	Assy, Kit, Clutch Keys	62	7294J	Disc, Brake
23	73810500	Nut, Lock, 5/16-24	63	108989X	Spacer, Brake Puck
24	142676	Shaft, Intermediate	64	160952	Jaw, Brake
25	2244J	Key, Woodruff, No. 61	65	120954X	Pin, Dowel
26	105916X	Ring, Retaining	66	160953	Screw, Tapping, 5/16-18 X 2.35
27	120470X	Sprocket, 1 8T	67	138244	Lever, Actuating
28	110070X	Spacer, 1. 131 X 1.45 X .494	68	108996X	Washer, Plain, .321 X 1.00 X .055
29	142677	Gear, Spur, 37T	69	160954	Bracket, Anti-Rotation
30	124644X	Gear, Spur, 30T	70	120951X	Puck, Friction
31	108980X	Gear, Spur, 25T	71	174256	Washer, Anti Rotation
32	120406X	Gear, Spur, 22T	72	120416X	Grease
33	134796	Gear, Spur, 1 9T			
34	134797	Spacer, 1. 133 X 1.50 X .375			
35	105925X	Washer, Plain, .640 X 1.37 X .061			
36	2228J	Washer, Plain, .632 X 1.00 X .046			
37	170987	Washer, Plain, .632 X 1.00 X .031			
38	174255	Assy, Gear, Comb., 12T & 30T			
39	124639X	Shaft, Idler			
40	120472X	Spacer, .633 X .87 X .755			

**NOTE:** All component dimensions given in U.S. inches  
1 inch = 25.4 mm

\* Use in various combinations to maintain proper clearances.

\*\* Order Key No. 15.

\*\*\* Silicone Sealant to be applied between Upper and Lower Housings (use Loctite Ultra Gray Silicone 5699 or equivalent).

# REPAIR PARTS

TRACTOR- -MODEL NO. 917. 274100

BRIGGS & STRATTON ENGINE - - MODEL NUMBER 283H07, TYPE NUMBER 0400-B1

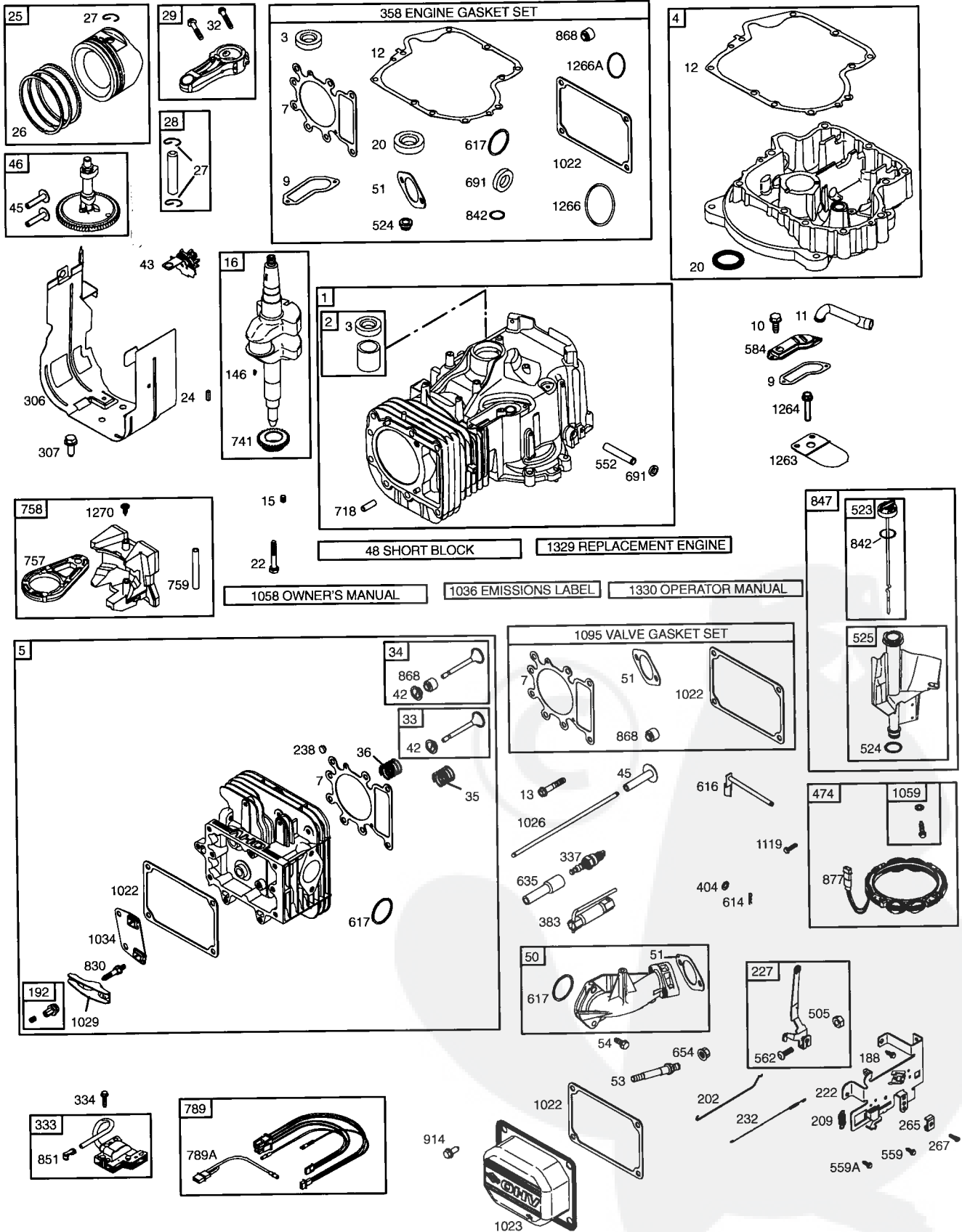

# REPAIR PARTS

TRACTOR- -MODEL NO. 917. 274100

BRIGGS & STRATTON ENGINE - - MODEL NUMBER 283H07, TYPE NUMBER 0400-B1

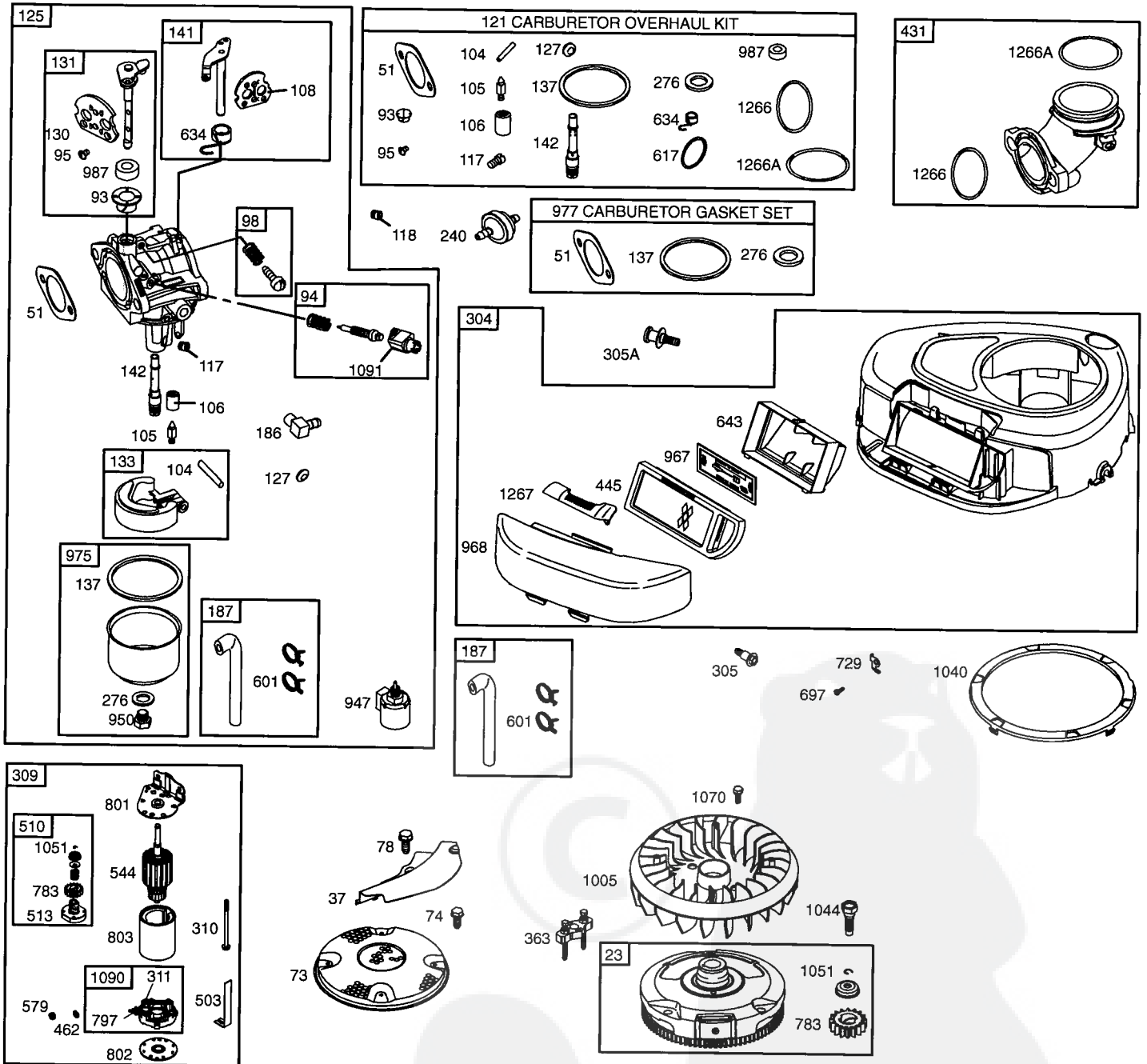

# REPAIR PARTS

## TRACTOR- -MODEL NO. 917. 274100

### BRIGGS & STRATTON ENGINE - - MODEL NUMBER 283H07, TYPE NUMBER 0400-B1

KEY NO.	PART NO.	DESCRIPTION	KEY NO.	PART NO.	DESCRIPTION
1	697132	Cylinder Assembly	105	231855s	∅ Valve-Float Needle (Walbro)
2	399265	Kit-Bushing/Seal (Magneto Side)	105A	696136	∅ Valve-Float Needle (Nikki)
3	391086s	• Seal-Oil (Magneto Side)	106	690577	∅ Seat-Inlet (Walbro)
4	697106	Sump-Engine	108	692344	Valve-Choke (Walbro)
5	698147	Head-Cylinder	108A	695419	Valve-Choke (Nikki)
7	273280s	+ Gasket-Cylinder Head	117	694352	∅ Jet-Main (Standard)
9	697109	• Gasket-Breather	117A	699457	∅ Jet-Main (Standard)
10	697157	Screw (Breather Assembly)	118	697228	Jet-Main (High Altitude) (Walbro)
11	697113	Tube-Breather	118A	699458	Jet-Main (High Altitude) (Nikki)
12	697110	• Gasket-Crankcase	121	697241	Kit-Carburetor Overhaul (Walbro)
13	690360	Screw (Cylinder Head)	121A	699521	Kit-Carburetor Overhaul (Nikki)
15	690946	Plug-Oil Drain	125	791888	Carburetor
16	697127	Crankshaft	127	695005	Plug-Welch (Walbro)
20	690947	• Seal-Oil (PTO Side)	127A	690727	∅ Plug-Welch (Nikki)
22	692125	Screw (Crankcase Cover/Sump)	130	691750	Valve-Throttle (Walbro)
23	693557	Flywheel	130A	699500	Valve-Throttle (Nikki)
24	222698s	Key-Flywheel	131	494379	Kit-Throttle Shaft (Walbro)
25	792305	Piston Assembly (Standard)	131A	699501	Kit-Throttle Shaft (Nikki)
--	792642	Piston Assembly (.020" Oversize)	133	494381	Float-Carburetor (Walbro)
26	792306	Ring Set (Standard)	133A	694914	Float-Carburetor (Nikki)
--	792643	Ring Set (.020" Oversize)	135	698780	Tube-Fuel Transfer (Nikki)
27	698469	Lock-Piston Pin	137	281165s	∅± Gasket-Float Bowl (Walbro)
28	697099	Pin-Piston	137A	698781	∅ Gasket-Float Bowl (Nikki)
29	791631	Rod-Connecting (Standard)	141	495931	Kit-Choke Shaft (Walbro)
32	791118	Screw (Connecting Rod)	141A	695420	Kit-Choke Shaft (Nikki)
33	695760	Valve-Exhaust	142	697140	∅ Nozzle-Carburetor
34	695761	Valve-Intake	146	691639	Key-Timing
35	691279	Spring-Valve (Intake)	186	698174	Connector-Hose
36	691279	Spring-Valve (Exhaust)	187	791805	Line-Fuel (Molded)
37	697352	Guard-Flywheel	188	691693	Screw (Control Bracket)
42	499586	Keeper-Valve	192	691986	Adjuster-Rocker Arm
43	691968	Slinger-Governor/Oil	202	691841	Link-Mechanical Governor
45	690564	Tappet-Valve	209	692208	Spring-Governor
46	790400	Camshaft	222	694042	Bracket-Control
48	697761	Short Block	227	691374	Lever-Governor Control
50	690193	Manifold-Intake	232	691842	Spring-Governor
51	692137	•∅± Gasket-Intake	238	691843	Cap-Valve
53	690227	Stud (Carburetor)	240	394358s	Filter-Fuel
54	691148	Screw (Intake Manifold)	265	691024	Clamp-Casing
73	697133	Screen-Rotating	267	695134	Screw (Casing Clamp)
74	697897	Screw (Rotating Screen)	276	692255	∅± Washer-Sealing (Walbro)
78	691003	Screw (Flywheel Guard)	276A	695410	Washer-Sealing (Nikki)
93	690602	∅ Bushing-Throttle Shaft	304	698402	Housing-Blower
94	498030	Kit-Idle Mixture (Walbro)	305	697102	Screw (Blower Housing)
94A	695425	Kit-Idle Mixture (Nikki)	305A	697103	Screw (Blower Housing)
95	691636	∅ Screw (Throttle Valve) (Walbro)	306	697107	Shield-Cylinder
95A	690718	∅ Screw (Throttle Valve) (Nikki)			
98	495800	Kit-Idle Speed (Walbro)			
98A	695408	Kit-Idle Speed (Nikki)			
104	690525	∅ Pin-Float Hinge (Walbro)			
104A	694918	∅ Pin-Float Hinge (Nikki)			

- Included in Engine Gasket Set, Key. No. 358
- ∅ Included in Carburetor Overhaul Kit, Key. No. 121
- ± Included in Carburetor Gasket Set, Key. No. 977
- + Included in Valve Gasket Set, Key. No. 1095

**NOTE:** All component dimensions given in U.S. inches 1 inch = 25.4 mm



# REPAIR PARTS

## TRACTOR- -MODEL NO. 917. 274100

### BRIGGS & STRATTON ENGINE - - MODEL NUMBER 283H07, TYPE NUMBER 0400-B1

KEY NO.	PART NO.	DESCRIPTION	KEY NO.	PART NO.	DESCRIPTION
307	691003	Screw (Cylinder Shield)	803	693757	Housing-Starter
309	693551	Motor-Starter	830	691095	Stud (Rocker Arm)
310	690323	Bolt (Starter Motor)	842	691031	• Seal-O Ring (Dipstick Tube)
311	497608	Brush Set	847	790442	Dipstick/Tube Assembly
333	492341	Armature-Magneto	851	692424	Terminal-Spark Plug
334	691061	Screw (Magneto Armature)	868	690968	•+ Seal-Valve
337	691043	Plug-Spark	877	393456	Wire-Connector/Alternator
358	697151	Gasket Set-Engine	914	691108	Screw (Rocker Cover)
363	19203	Puller-Flywheel	947	694393	Solenoid-Fuel (Walbro)
383	89838	Wrench-Spark Plug	947A	699915	Solenoid-Fuel (Nikki)
404	691691	Washer (Governor Crank)	950	691657	Screw (Float Bowl)
431	697122	Elbow-Intake	967	697015	Filter-Pre Cleaner
445	698083	Filter-Air Cleaner Cartridge	968	698403	Cover-Air Cleaner
462	691261	Washer (Starter Cable)	975	495933	Bowl-Float (Walbro)
474	696459	Alternator	975A	699502	Bowl-Float (Nikki)
503	691532	Strap-Starter	977	690192	Gasket Set-Carburetor
505	691251	Nut (Governor Control Lever)	987	691326	∅ Seal-Throttle Shaft (Walbro)
510	693699	Drive-Starter	987A	698777	∅ Seal-Throttle Shaft (Nikki)
513	692024	Clutch-Drive	1005	699043	Fan-Flywheel
523	699908	Dipstick	1022	272475s	•+ Gasket-Rocker Cover
524	691032	• Seal-Dipstick Tube	1023	791079	Cover-Rocker Arm
525	697184	Tube-Dipstick	1026	692003	Rod-Push (Intake)
544	692034	Starter-Armature	1026	692011	Rod-Push (Exhaust)
552	697144	Bushing-Governor Crank	1029	691751	Arm-Rocker
559	697561	Screw (Remote Choke Stop)	1034	690822	Guide-Push Rod
559A	693675	Screw (Remote Choke Stop)	1036	792450	Label-Emissions
562	691119	Bolt (Governor Control Lever)	1040	698368	Plate-Trim
579	691029	Nut (Starter Cable)	1044	698139	Screw (Flywheel)
584	697112	Cover-Breather Passage	1051	691265	Ring-Retaining
601	791850	Clamp-Hose	1058	275935	Owner's Manual
614	691620	Pin-Cotter	1059	698516	Kit-Screw/Washer
616	692012	Crank-Governor	1070	690372	Screw (Flywheel Fan)
617	692138	∅ • Seal-O Ring (Intake Manifold)	1090	691293	Retainer-Brush
634	690802	∅ Spring/Seal Assembly (Walbro)	1091	691333	Cap-Limiter
634A	698779	∅ Spring/Seal Assembly (Nikki)	1095	691581	Gasket Set-Valve
635	691909	Boot-Spark Plug	1119	691183	Screw (Alternator)
643	698401	Retainer-Air Filter	1127	695407	Screw (Float Bowl)(Nikki)
654	690958	Nut (Carburetor)	1263	697124	Reed-Breather
691	692407	• Seal-Governor Shaft	1264	697104	Screw (Breather Reed)
697	690372	Screw (Drive Cap)	1266	691917	•∅ Seal-O Ring (Intake Elbow)
718	690959	Pin-Locating	1266A	697123	•∅ Seal-O Ring (Intake Elbow)
729	691224	Clip-Wire	1267	697419	Latch-Blower Housing
741	697128	Gear-Timing	1270	697156	Plug-AVS Counterweight
757	697607	Link-Counterweight	1329	286H07-0026	Replacement Engine (Transfer the speed limiter control assembly and governor spring to the replacement engine. Remove 691840)
758	697134	Counterweight			Owner's Manual
759	697392	Pin-Counterweight			
783	693713	Gear-Pinion			
789	698329	Harness-Wiring			
789A	790544	Harness-Wiring	1330	275038	
797	693167	Nut (Brush Retainer)			
801	691283	Cap-Drive			
802	691286	Cap-End			

**NOTE:** All component dimensions given in U.S. inches 1 inch = 25.4 mm

## LIMITED WARRANTY ON CRAFTSMAN TRACTOR AND BATTERY

### 2-YEAR ON TRACTOR

When used and maintained according to the operator's manual instructions, if this tractor fails due to a defect in material or workmanship within two years from the date of purchase, call 1-800-4-MY-HOME® to arrange for free repair.

During the first 30 days of purchase, there will be no charge to service the product in your home. For your convenience, in-home warranty service will still be available after the first 30 days of purchase, but a trip charge will apply. This charge will be waived if you transport the product to an authorized Craftsman drop-off location. For the nearest authorized location, call 1-800-4-MY-HOME®.

Tractor warranty coverage does not include:

- Expendable items which become worn during normal use, including but not limited to blades, spark plugs, air cleaners, belts, and oil filters.
- Standard maintenance servicing, oil changes, or tune-ups.
- Tire replacement or repair caused by punctures from outside objects, such as nails, thorns, stumps, or glass.
- Repairs necessary because of operator abuse, including but not limited to damage caused by towing objects beyond the capability of the tractor, impacting objects that bend the frame or crankshaft, or over-speeding the engine.
- Repairs necessary because of operator negligence, including but not limited to electrical and mechanical damage caused by improper storage, failure to use the proper grade and amount of engine oil, failure to keep the deck clear of flammable debris, or failure to maintain the equipment according to the instructions contained in the operator's manual.
- Engine (fuel system) cleaning or repairs necessary because of fuel determined to be contaminated or oxidized (stale). In general, fuel should be used within 30 days of its purchase date.
- Normal deterioration and wear of the exterior finishes, or product label replacement.
- The tractor battery, which is covered for only 90 days as stated below.

### 90-DAYS ON BATTERY

For ninety (90) days from the date of purchase, if the battery included with this tractor is defective in material or workmanship (our testing proves it will not hold a charge), it will be replaced free of charge.

During the first 30 days of purchase, there will be no charges to replace the battery in your home. For your convenience, in-home warranty service will still be available after the first 30 days of purchase, but a trip charge will apply. This charge will be waived if you transport the battery to an authorized Craftsman drop-off location. For the nearest authorized location, call 1-800-4-MY-HOME®.

All tractor and battery warranty coverage is void if this product is used for commercial or rental purposes.

This warranty applies only while this product is within the United States.

This warranty gives you specific legal rights, and you may also have other rights, which vary, from state to state.

**Sears, Roebuck and Co., Dept. 817WA, Hoffman Estates, IL 60179**



**CRAFTSMAN®**