

REPAIR PARTS MANUAL
MODEL NO. 992310

CRAFTSMAN[®]

581904527

HOW TO USE THIS MANUAL

This manual is designed to provide the customer with a means to identify the parts on his/her tractor when ordering repair parts. The illustrations may or may not represent the actual assemblies; therefore, it is not recommended to use this manual as a guide to assemble or disassemble the tractor. Some hardware and parts are drawn larger in order to more readily identify them.

Each tractor has its own model number.

The model number for your tractor can be found on the fender under the seat.

When ordering parts, always give the following information:

- Product - Lawn Tractor
- MODEL NUMBER - **992310**
- Part Number
- Part Description

TABLE OF CONTENTS

SCHEMATIC	3
ELECTRICAL.....	4-5
CHASSIS	6-7
DRIVE.....	8-9
ENGINE.....	10-11
STEERING	12
SEAT	13
MOWER DECK	14-15
MOWER LIFT.....	16
DECALS.....	17
TRANSAXLE BREAKDOWN	18-19
ENGINE BREAKDOWN.....	20-23
WARRANTY.....	BACK COVER

TRACTOR - - MODEL NUMBER 917.992310

SCHEMATIC

SCH12

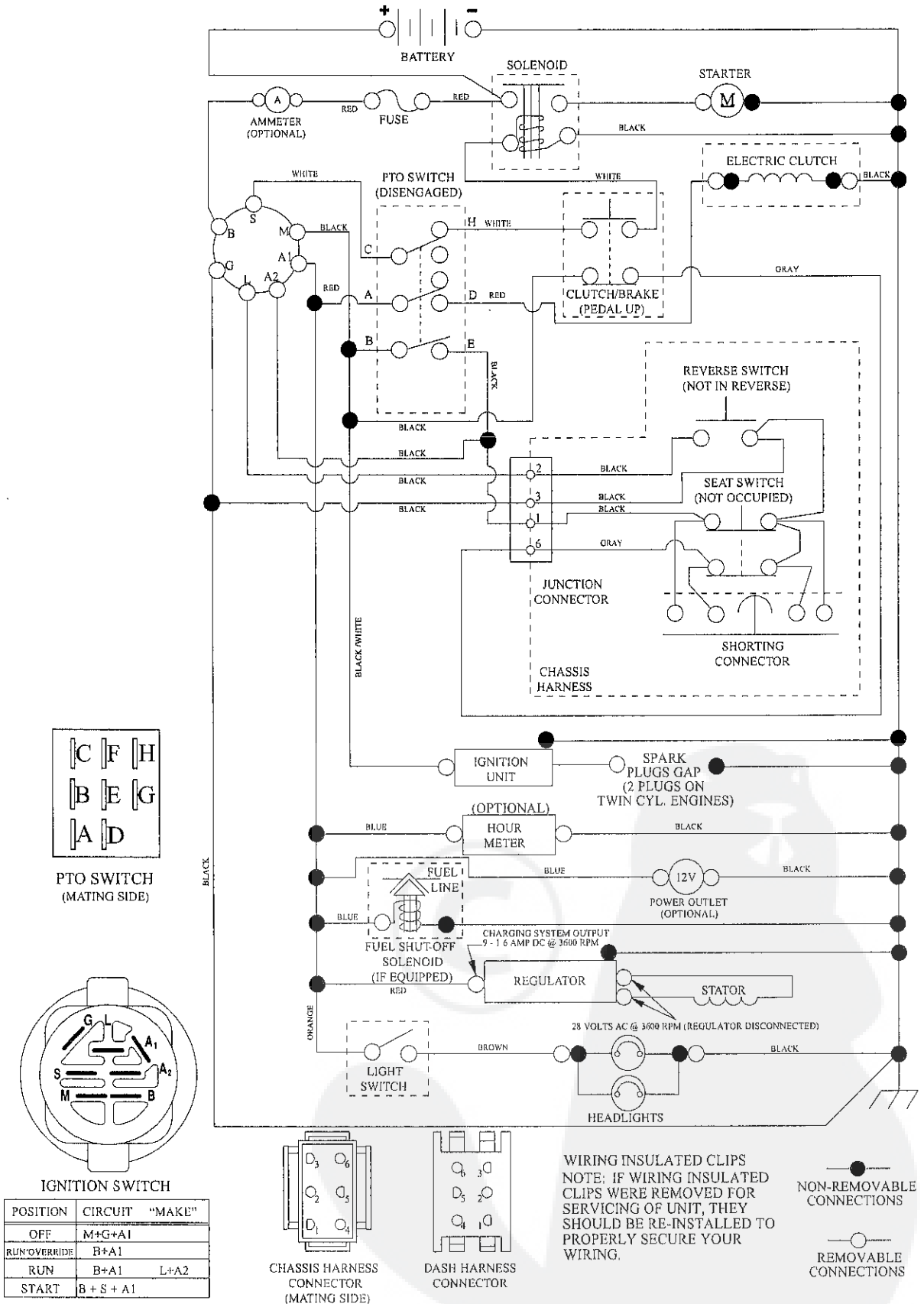

TRACTOR -- MODEL NUMBER 917.992310

ELECTRICAL

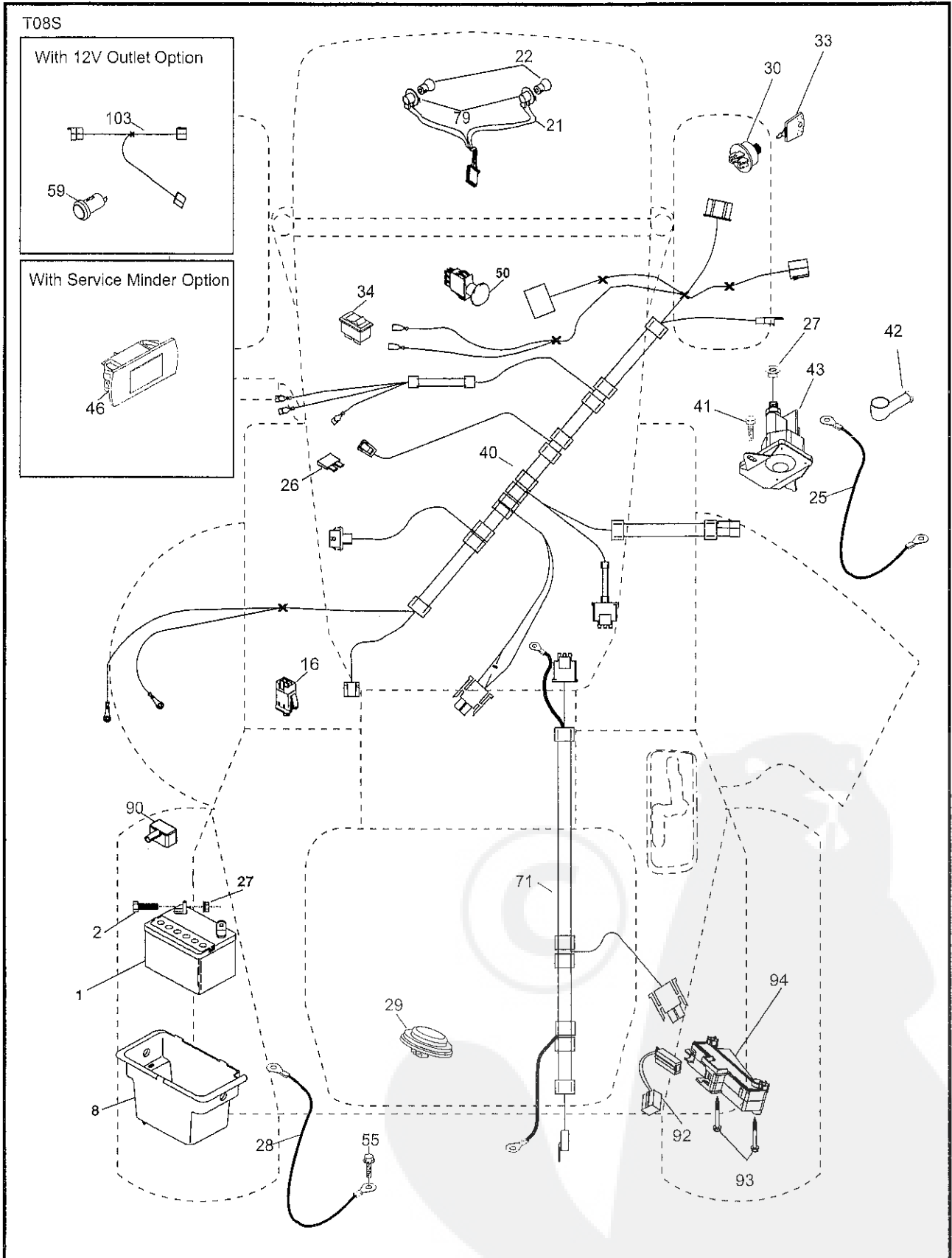

TRACTOR - - MODEL NUMBER 917.992310

ELECTRICAL

KEY NO.	PART NO.	DESCRIPTION
1	163465	Battery
2	74760412	Bolt Hex Hd 1/4-20 unc x 3/4
8	193228	Box Battery
16	176138	Switch Interlock Push-In
21	400252	Harness Socket Light w/4152J
22	4152J	Bulb Light
25	412894	Cable Starter
26	175158	Fuse
27	73510400	Nut Keps Hex 1/4-20 unc
28	198885	Cable, Ground
29	401545	Switch, Seat
30	193350	Switch, Ign
33	411934	Key/Chain
34	110712X	Switch Light / Reset
40	401104	Harness Ign. Dash
41	17720408	Screw Thd Cut 1/4-20 x 1/2
42	131563	Cover, Terminal
43	192507	Solenoid
50	174651	Switch PTO
55	17060512	Screw Thdrol 5/16-18 x 3/4 TYTT
71	441544	Harness Ign. Chassis
79	175242	Bulbholder Asm. Incan Descent
90	435395	Cover Terminal Battery
92	196615	Harness Pigtail
93	192540	Screw Plastite
94	191834	Module reverse

NOTE: All component dimensions given in U.S. inches
1 inch = 25.4 mm

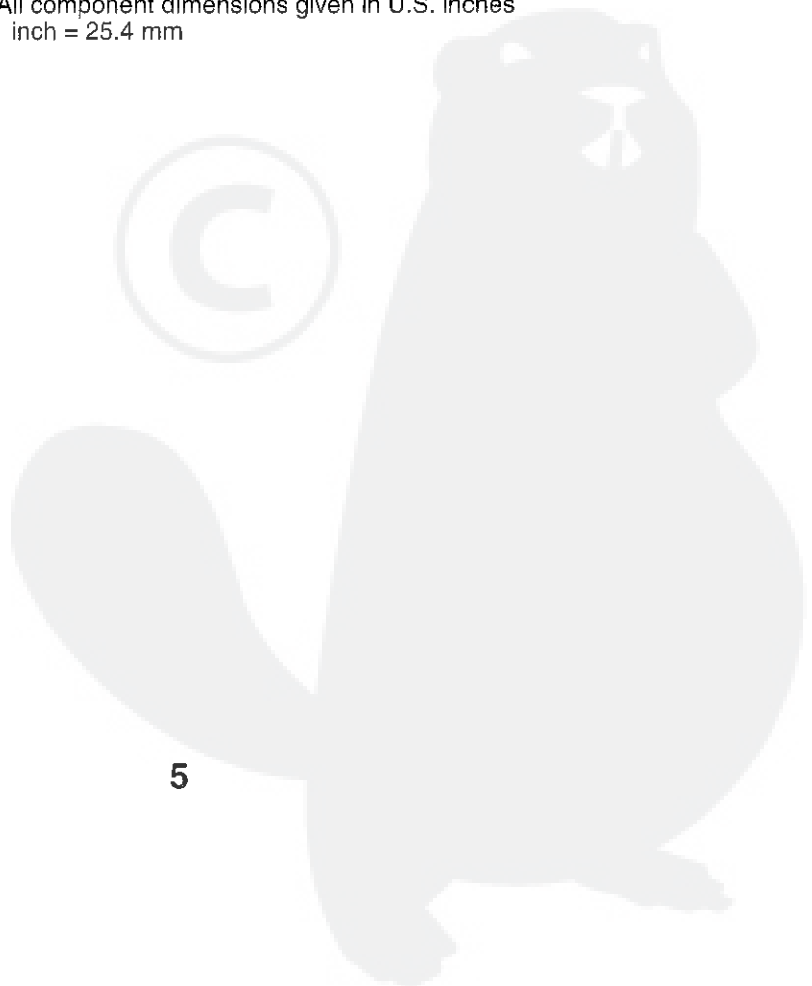

TRACTOR -- MODEL NUMBER 917.992310

CHASSIS ASSEMBLY

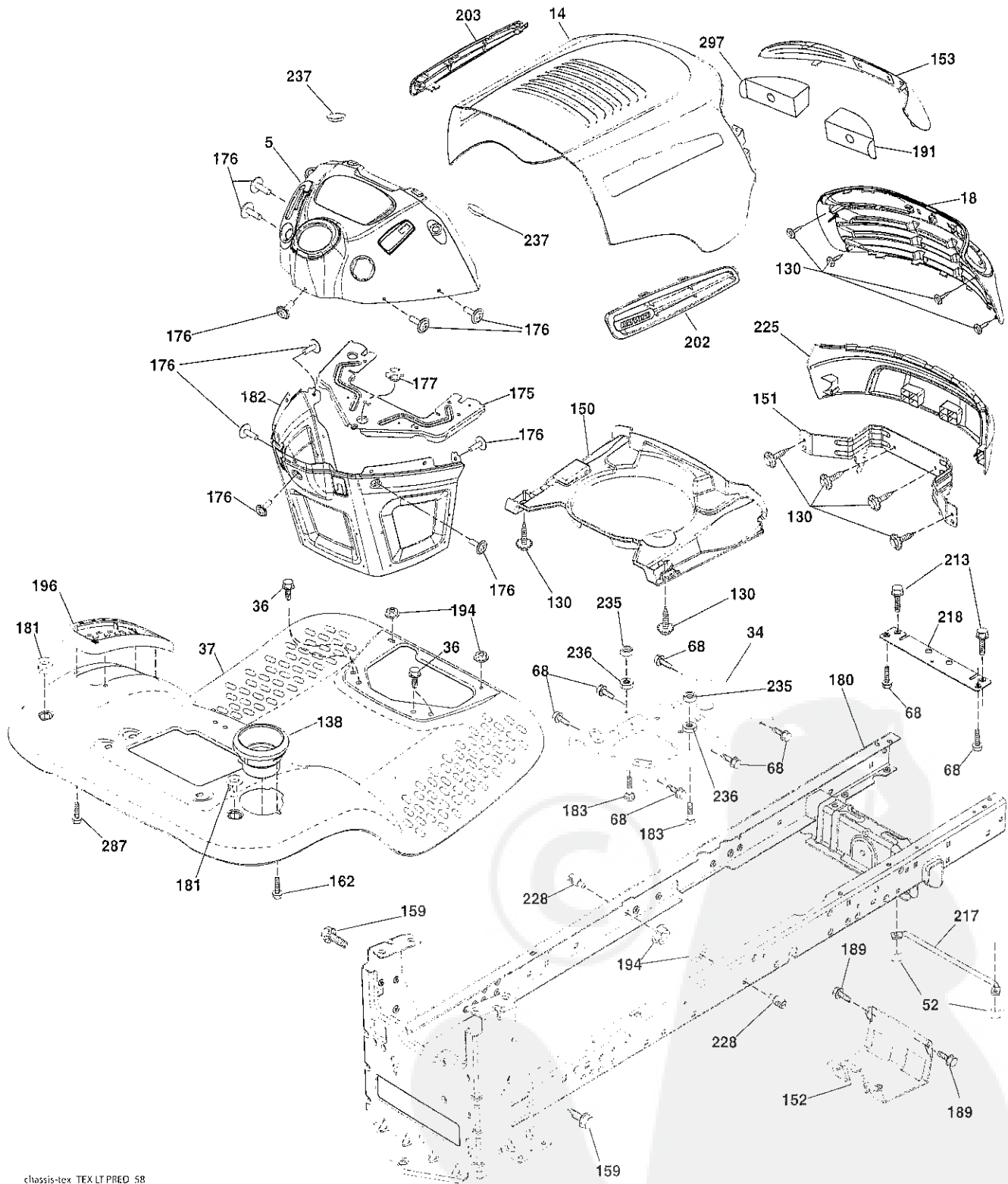

chassis-tex TEX LT PRED 58

TRACTOR - - MODEL NUMBER 917.992310

CHASSIS ASSEMBLY

KEY NO.	PART NO.	DESCRIPTION
5	400800X428	Dash
14	198416X615	Hood
18	423156	Grille
34	580910801	Plate Engine
36	17060512	Screw 5/16-18 x 3/4
37	414872X615	Fender
52	73680500	Nut Crown Lock 5/16-18
68	17490508	Screw Thdrol 5/16-18 x 1/2
130	416358	Screw #10 x 0.750
138	193224X428	Cupholder
150	400267	Duct Heat Hood
151	187568	Bracket Pivot
152	199535	Shield Browning/Debris
153	400550X599	Lens
159	17000612	Screw Hexwsh Thdrol 3/8-16 x 3/4
162	142432	Screw Hex Wsh Hi-Lo 1/4 x 1/2
175	199472	Crossmember
176	400776	Screw 10-24 x 5/8 Wshd Qdrx
177	195228	Bushing Steering
180	195457	Chassis
181	193102X428	Bushing Mtg. Fender Crgo.
182	407176	Dash Lower
183	74520520	Bolt Full Thd 5/16-18 x 1-1/4
189	17000512	Screw 5/16-18 x 3/4
191	416502	Insert Reflective RH
194	73900500	Nut Lock Hex Flange 5/16-18
196	414579	Console Asm. Deck Lift
202	580427401	Vent Hood Side Panel RH
203	580427501	Vent Hood Side Panel LH
213	74760512	Bolt Hex HD 5/16-18 unc x 3/4
217	409167	Rod Pivot Hood
218	196395	X-Piece Hoodstop
225	400549X615	Bumper
228	195161	Stud Fastener
235	406129	Spacer Fender
236	73930500	Nut Center Lock 5/16-18
237	403704	Plug Mount Cargo
287	17600406	Screw 1/4-20 x 3/8
297	401827	Insert Reflective LH
--	404951X428	Plug Dash Serviceminder

NOTE: All component dimensions given in U.S. inches
1 inch = 25.4 mm

TRACTOR - - MODEL NUMBER 917.992310

GROUND DRIVE

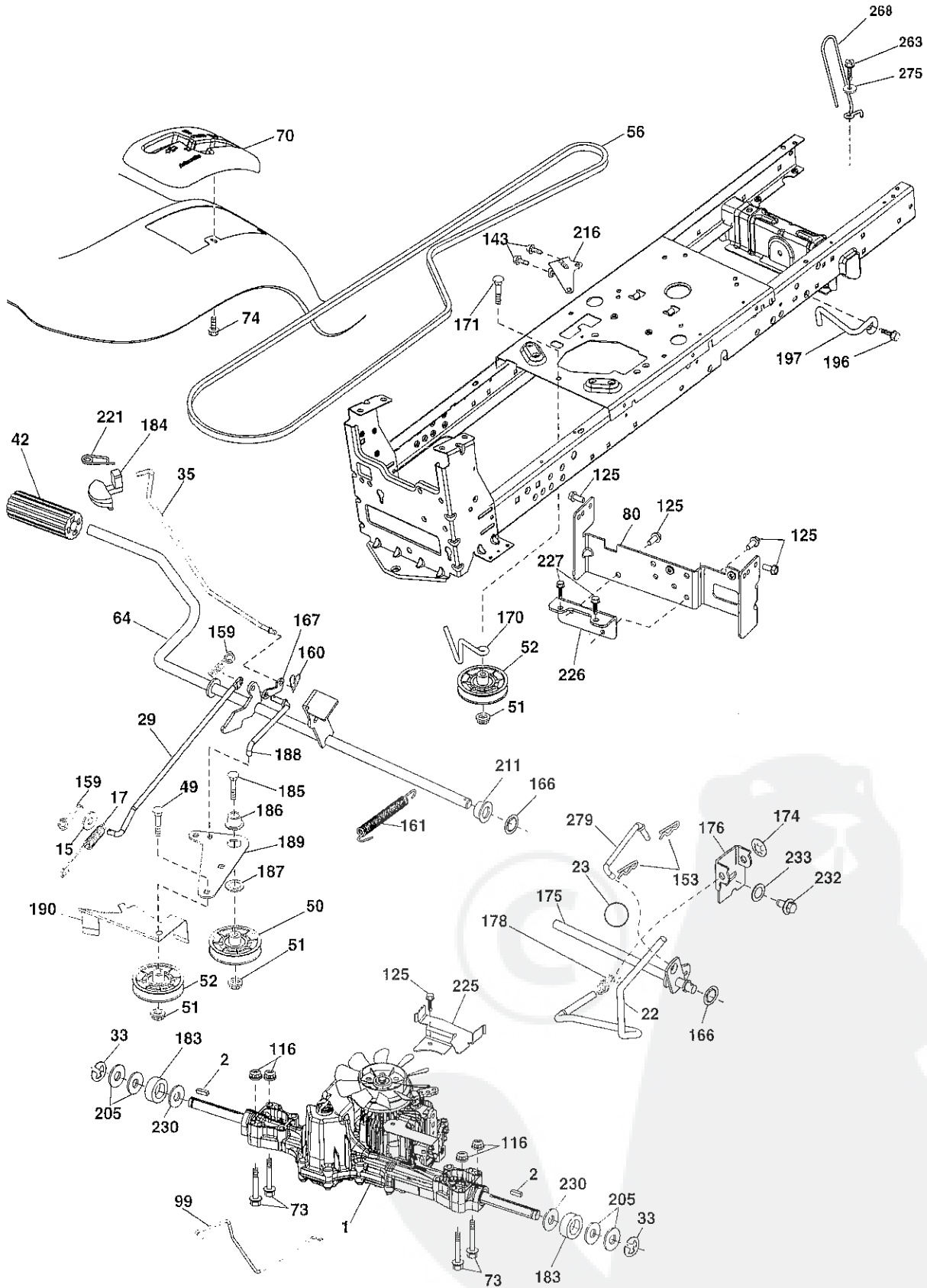

drive-tex_K46_fender_21_r2

TRACTOR - - MODEL NUMBER 917.992310

GROUND DRIVE

KEY NO.	PART NO.	DESCRIPTION	KEY NO.	PART NO.	DESCRIPTION
1	- - - -	Transaxle, Tufftorq K46BA (448348) (See transaxle break down.)	174	197289	Nut Push
2	123583X	Key Square	175	406208	Shaft Asm Shift
15	19131316	Washer 13/32 x 13/16 x 16 Ga.	176	196214	Arm Clevis Rod Shift
17	413678	Spring, Brake	178	197456	Spring Shift
22	197660	Rod Shift	183	137057	Spacer Axle
23	140845	Knob	184	199996X667	Handle Parking Brake
29	403806	Rod, Brake	185	72110622	Bolt
33	12000001	Ring E	186	194321	Spacer Retainer
35	401031	Rod, Brake, Park	187	19133210	Washer
42	8883R	Cover, Foot Pedal	188	194323	Link Clutch Ground Drive
49	72110614	Bolt	189	194317	Bellicrank Ground Drive
50	194327	Pulley Idler Flat	190	194318	Keeper Bellcrank Ground Drive
51	73900600	Lock Nut 3/8-16	196	17000616	Screw 3/8-16 x 1
52	194326	Idler V-Groove 910" Offset	197	195804	Link Clutch Anti-Rotation
56	130969	V-Belt, Drive	205	121748X	Washer 25/32 x 1-5/8 x 16 Ga.
64	196200	Shaft Asm. Pedal Brake Control	211	196212	Bushing Shaft
70	193220X428	Console	216	196131	Bracket Pulley Idler
73	74490540	Bolt Hex 5/16-18 x 2-1/2	221	403187	Retainer Spring Clip Handle
74	142432	Screw 1/4 x 1/2	225	403319	Keeper Belt Transaxle
80	440619	Strap Torque	226	401564	Bracket Mount Torque
99	415742	Rod Spring Bypass	227	17490512	Screw Thdrol 5/26-18 x 3/4
116	73900500	Nut Lock Hex Flange 5/16-18	230	188967	Washer Harden .793 x 1.637 x 060
125	17000512	Screw 5/16-18 x 3/4	232	74780716	Bolt 7/16-14 x 1 Gr 5
143	17490508	Screw THDROL 5/16-18	233	405296	Washer Serrated
153	4497H	Retainer Spring 1"	263	17000612	Screw 3/8-16 x 3/4
159	76020412	Pin Cotter 1/8 x 3/4	268	182402	Guard Muffler
160	169484	Retainer Clip	275	19131614	Washer 13/32 x 1 x 14 Ga.
161	105709X	Spring, Return, Clutch	279	406207	Link Shift
166	429164	Nut Push .625			
167	405257	Latch Brake Parking			
170	194322	Keeper Belt Centerspan			
171	72110616	Bolt Rdhd 3/8-16 x 2			

NOTE: All component dimensions given in U.S. inches
1 inch = 25.4 mm



TRACTOR - - MODEL NUMBER 917.992310

ENGINE

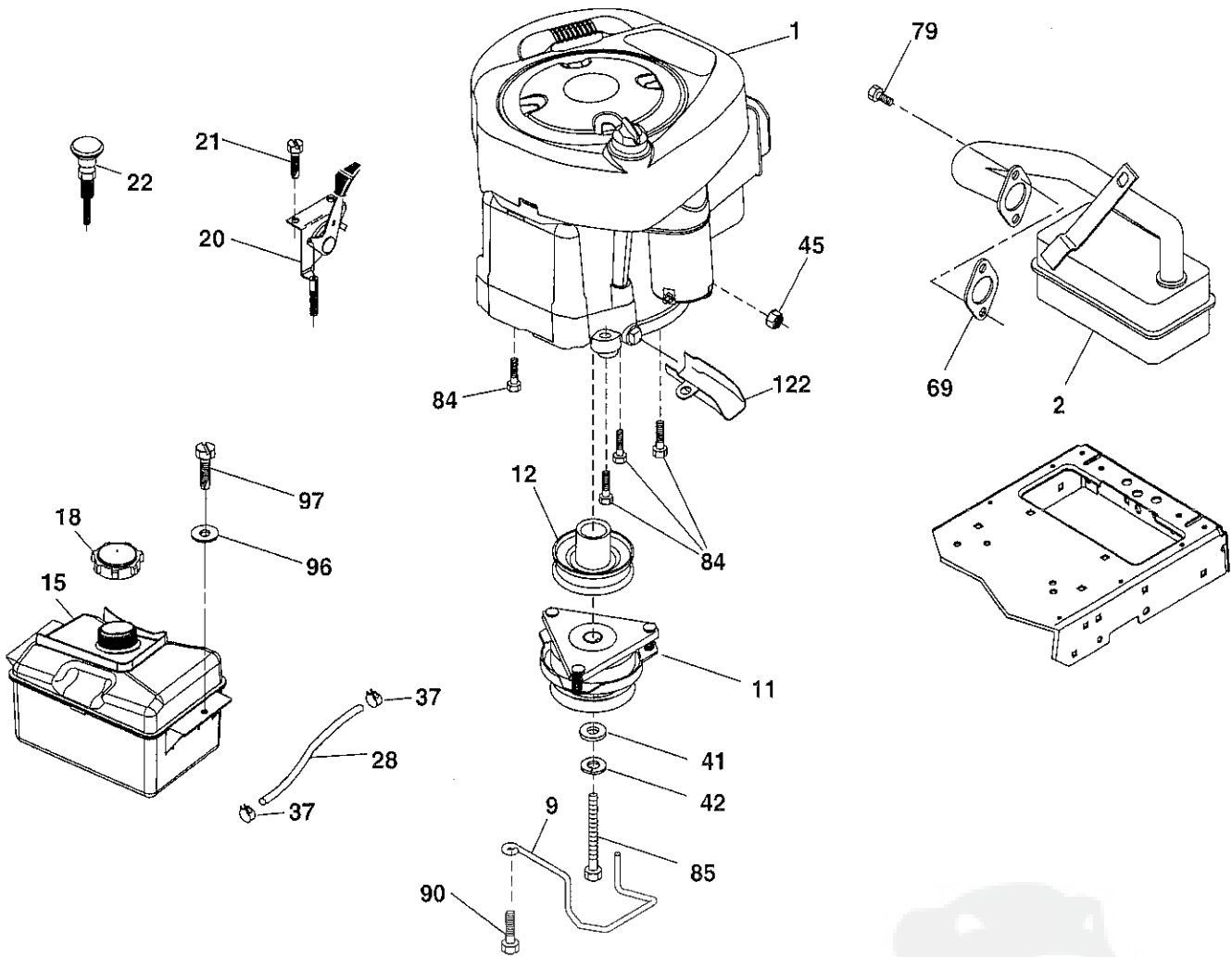

29

OPTIONAL EQUIPMENT

Spark Arrester

engine-tex_BS_49

TRACTOR - - MODEL NUMBER 917.992310

ENGINE

KEY NO.	PART NO.	DESCRIPTION
1	- - - -	Engine B&S Model No. 31P677-0156-B1(581880601)(See engine breakdown.)
2	137352	Muffler
9	194320	Keeper Belt Engine
11	180505	Clutch
12	405097	Pulley Engine
15	581289901	Tank Fuel 1.50
18	430220	Cap Fuel
20	176636X428	Control Throttle/Choke
21	416358	Screw #10 x 0.750
22	187771X428	Control Choke
28	137040	Fuel Line
29	137180	Spark Arrester Kit
37	123487X	Clamp Hose
41	126197X	Washer 1-1/2 x 15/32 x .250
42	10040700	Washer Lock 7/16
45	73510400	Nut Keps Hex 1/4-20 unc
69	165291	Gasket
79	192334	Screw Socket Hd 5/16-18 x .75
84	17060620	Screw 3/8-16 x 1-1/4
85	173937	Bolt Hex 7/16-20 x 4 x Gr. 5-1.5
90	17000616	Screw 3/8-16 x 1.0
96	19091416	Washer 9/32 x 7/8 x 16 Ga.
97	17670412	Screw 1/4-20 x 3/4
122	421922	Extension Drain Oil

NOTE: All component dimensions given in U.S. inches
1 inch = 25.4 mm

Engine Power Rating Information

The gross power rating for individual gas engine models is labeled in accordance with SAE (Society of Automotive Engineers) code J1940 (Small Engine Power & Torque Rating Procedure), and rating performance has been obtained and corrected in accordance with SAE J1995 (Revision 2002-05). Torque values are derived at 3060 RPM; horsepower values are derived at 3600 RPM. Actual gross engine power will be lower and is affected by, among other things, ambient operating conditions and engine-to-engine variability. Given both the wide array of products on which engines are placed and the variety of environmental issues applicable to operating the equipment, the gas engine will not develop the rated gross power when used in a given piece of power equipment (actual "on-site" or net power). This difference is due to a variety of factors including, but not limited to, accessories (air cleaner, exhaust, charging, cooling, carburetor, fuel pump, etc.), application limitations, ambient operating conditions (temperature, humidity, altitude), and engine-to-engine variability. Due to manufacturing and capacity limitations, Briggs & Stratton may substitute an engine of higher rated power for this Series engine.

TRACTOR - - MODEL NUMBER 917.992310

STEERING ASSEMBLY

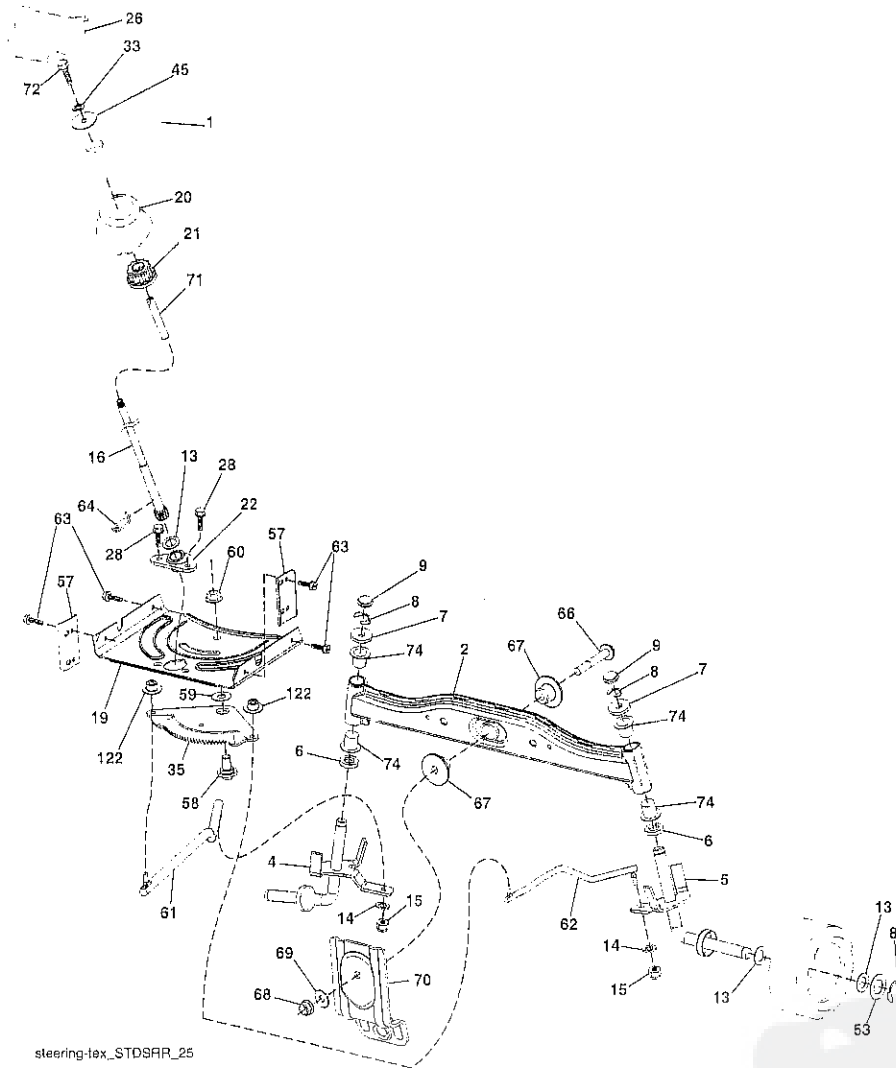

steering-lex_STDSRR_25

KEY NO.	PART NO.	DESCRIPTION
1	414885X428	Wheel, Steering
2	418168	Axle Asm., Front
4	403087	Spindle Asm., LH
5	403088	Spindle Asm., RH
6	6266H	Washer Thrust 0.75 x 1.23
7	121748X	Washer 25/32 x 1-5/8 x 16 Ga.
8	12000029	Ring, Clip #T5304-75
9	121232X	Cap, Spindle
13	121749X	Washer 25/32 x 1-1/4 x 16 Ga.
14	10040600	Washer Lock 3/8
15	73540600	Nut, Crown Lock 3/8-24 unf
16	429373	Shaft Steering
19	194729	Plate Steering
20	400803X428	Boot, Steering
21	186737	Adapter, Wheel Steering
22	420537	Steering Supt. Lower
26	414852X428	Insert, Wheel Steering
28	17000612	Screw 3/8-16 x 3/4
33	10040500	Washer Lock 5/16
35	194732	Gear, Sector Plate
45	19113812	Washer 11/32 x 2-3/8 x 12 Ga.
53	188967	Washer Hardened.793x1.637x.060

KEY NO.	PART NO.	DESCRIPTION
57	407465	Bracket Upstop
58	194747	Bolt Shoulder Sector Pivot CFM
59	194748	Washer Thrust Sector Steering
60	73971000	Nut Flange Lock 5/8-11
61	194740	Draglink, LH
62	194741	Draglink, RH
63	17000512	Screw 5/16-18 x 3/4
64	199849	Retainer Clip Spring Steering
66	71020748	Bolt Hex Fghd 7/16-14 x 3 Serr
67	194737	Bushing PM Front Axle
68	73900700	Nut Lock Flange 7/16-14 Gr. 5
69	199162	Washer 1.5 x .505 x .118
70	196197	Bracket Deck Susp. Front
71	190752	Shaft Ext. Steering
72	428982	Bolt Fin Hex 5/16-18 x 4
74	3366R	Bearing
122	444962	Cap Gear Sector

NOTE: All component dimensions give in U.S. inches
1 inch = 25.4 mm

TRACTOR - - MODEL NUMBER 917.992310

SEAT ASSEMBLY

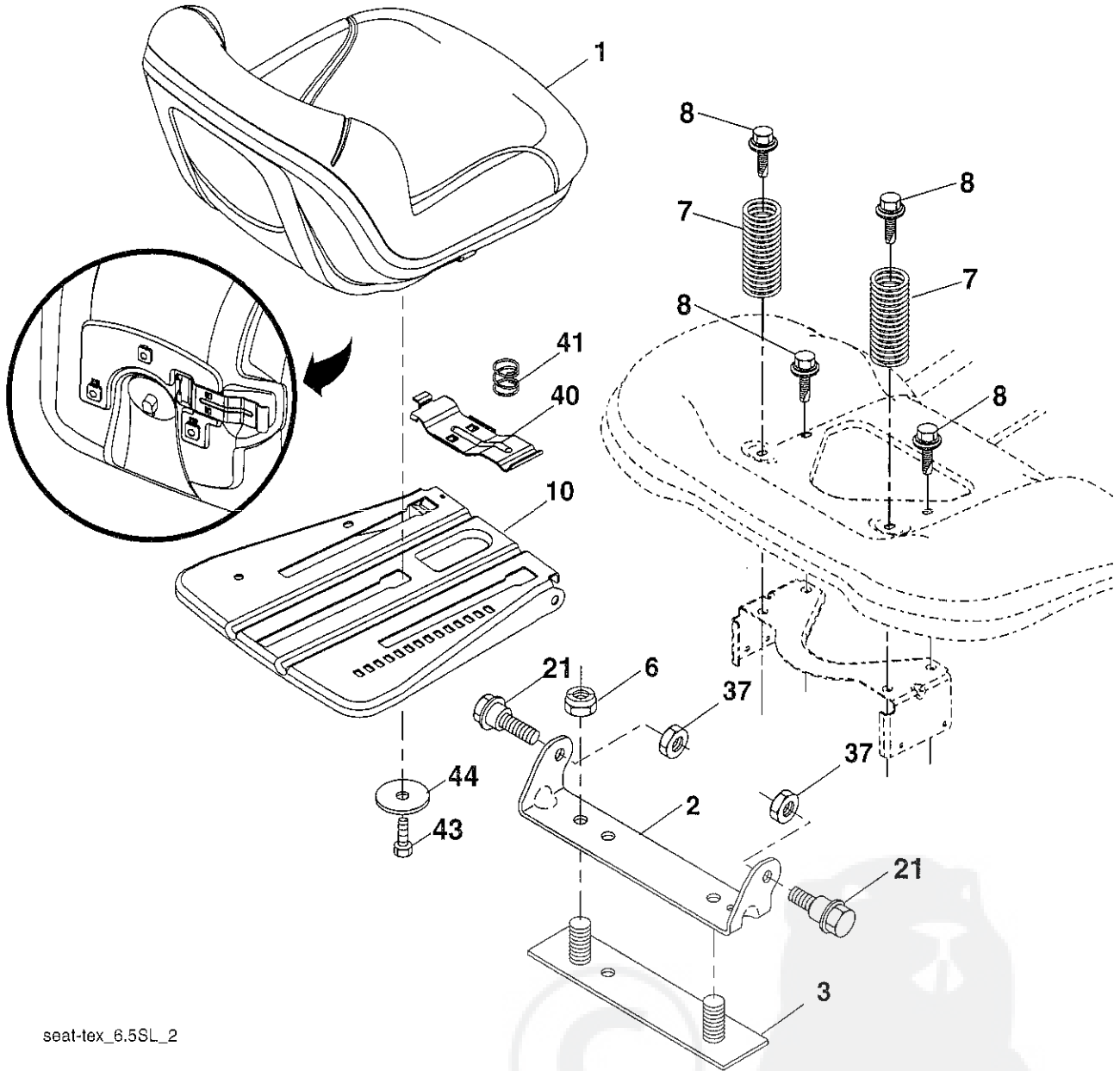

seat-tex_6.5SL_2

KEY NO.	PART NO.	DESCRIPTION
1	423645	Seat
2	180166	Bracket Pivot Fender
3	140675	Strap, Asm Fender
6	73800600	Nut, Lock w/Ins. 3/8-16 unc
7	124181X	Spring, Seat Cprsn
8	171877	Bolt 5/16-18 unc x 3/4 w/Sems
10	196977	Pan, Seat
21	171852	Bolt, Shoulder 5/16-18
37	73800500	Nut, Lock 5/16-18 unc

KEY NO.	PART NO.	DESCRIPTION
40	197661	Handle Slide
41	198200	Spring Latch
43	74760612	Bolt 3/8-16 unc x 3/4
44	19133812	Washer 13/32 x 2 3/8 x 12 Ga.

NOTE: All component dimensions give in U.S. inches
1 inch = 25.4 mm

TRACTOR - - MODEL NUMBER 917.992310

MOWER DECK

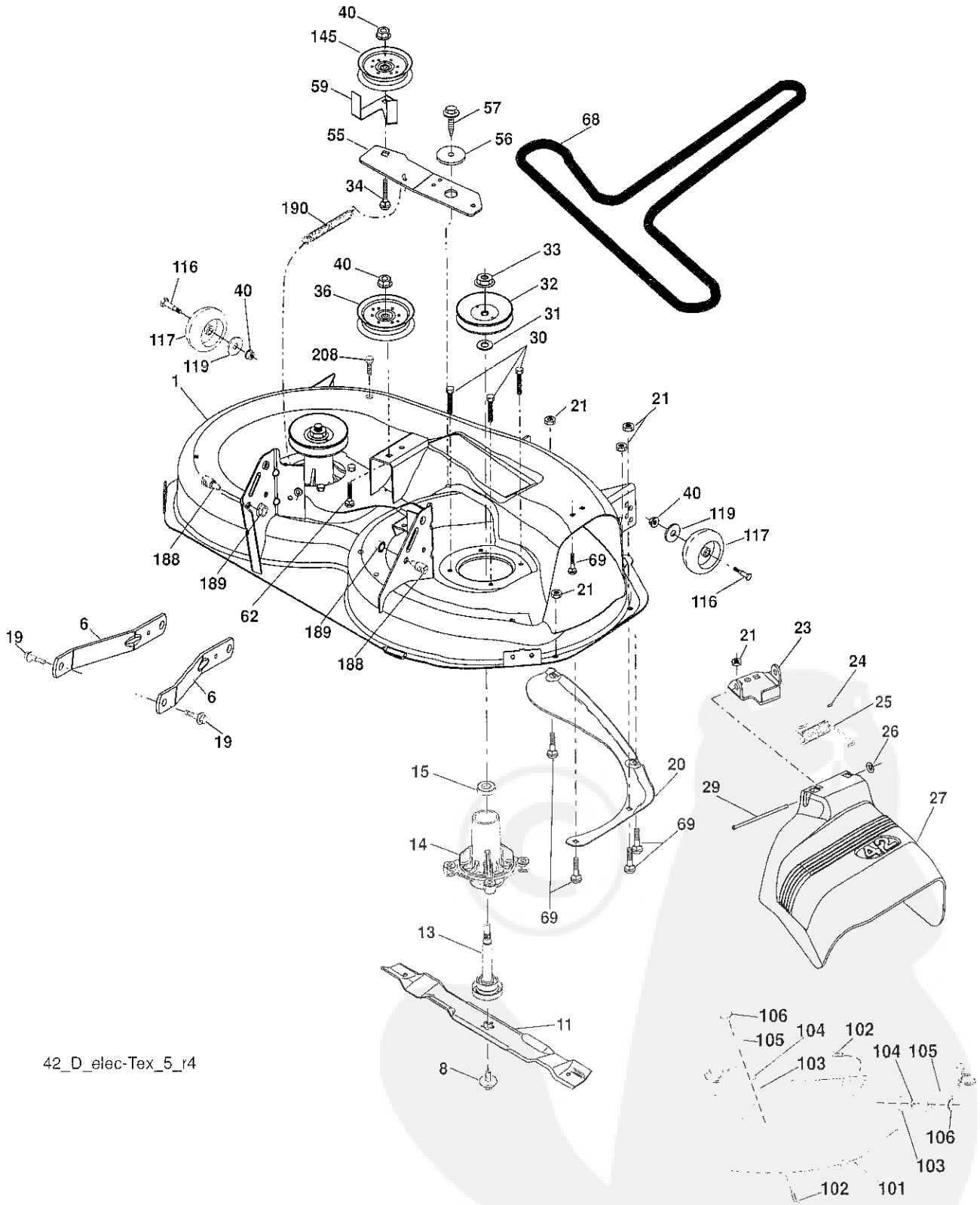

42_D_elec-Tex_5_r4

TRACTOR - - MODEL NUMBER 917.992310

MOWER DECK

KEY NO.	PART NO.	DESCRIPTION	KEY NO.	PART NO.	DESCRIPTION
1	196495	Mower Housing	59	141043	Guard, Tuv Idler (94)
6	195186	Arm Suspension	62	72110616	Bolt Rdhd Sqnk 3/8-16 unc x 2
8	193003	Bolt/Washer Asm 7/16-20 unf	67	198398X428	Handle, Clutch Cable
11	424752	Blade 3 in 1	68	144959	V-Belt
--	422719	Blade 3 in 1 Premium	69	72140505	Bolt Rdhd Sqnk 5/16-18 x 5/8
--	134149	Blade Mulching Standard	101	193107	Cover Mulching
--	139775	Blade Mulching Premium	102	71081010	Screw Pan Hd 10-24 x 5/8
--	138971	Blade, 42" Hi-Lift (For bagging or discharge)	103	19061216	Washer #10
13	192872	Shaft Assembly, Mandrel	104	10071000	Washer Lock #10
14	187281	Housing, Mandrel	105	160793	Latch Asm.
15	110485X	Bearing, Ball, Mandrel	106	2029J	Nut Weld
19	196539	Bolt, Shoulder	116	4898H	Bolt Shld. "A" 2.41 "B"1.66
20	159770	Baffle, Vortex	117	188606	Wheel Gage
21	73680500	Nut, Crownlock 5/16-18 unc	119	19121414	Washer 3/8 x 7/8 x 14 Ga.
23	192557	Bracket, Deflector	145	193197	Pulley, Idler, Flat
24	105304X	Cap, Sleeve	188	195161	Stud Fastener
25	197026	Spring, Torsion, Deflector	189	73900500	Nut Lock Hex Flange
26	110452X	Nut, Push	190	197251	Spring Mower Drive
27	424469	Shield, Deflector	208	17670608	Screw 3/8-16 x 1/2
29	131491	Rod, Hinge	--	192870	Mandrel Assembly (Includes housing (key# 14), shaft assembly (key# 13), bearing (key# 15) and nut (key# 33)only - pulley/washer and blade bolt/washers not included)
30	173984	Screw Thdrol Rolling Wsh Hd	--	583961701	Replacement Mower, Complete
31	187690	Washer, Spacer			
32	153535	Pulley, Mandrel			
33	400234	Nut, Toplock, Flanged			
34	72110612	Bolt Carr Sh. 3/8-16 x 1-1/2 Gr. 5			
36	197379	Pulley Idler			
40	73900600	Nut, Lock Flg. 3/8-16 unc			
55	437110	Arm, idler			
56	199092	Spacer, Retainer			
57	17000616	Screw Hexwsh Thd 3/8-16 x 1			

NOTE: All component dimensions given in U.S. inches
1 inch = 25.4 mm

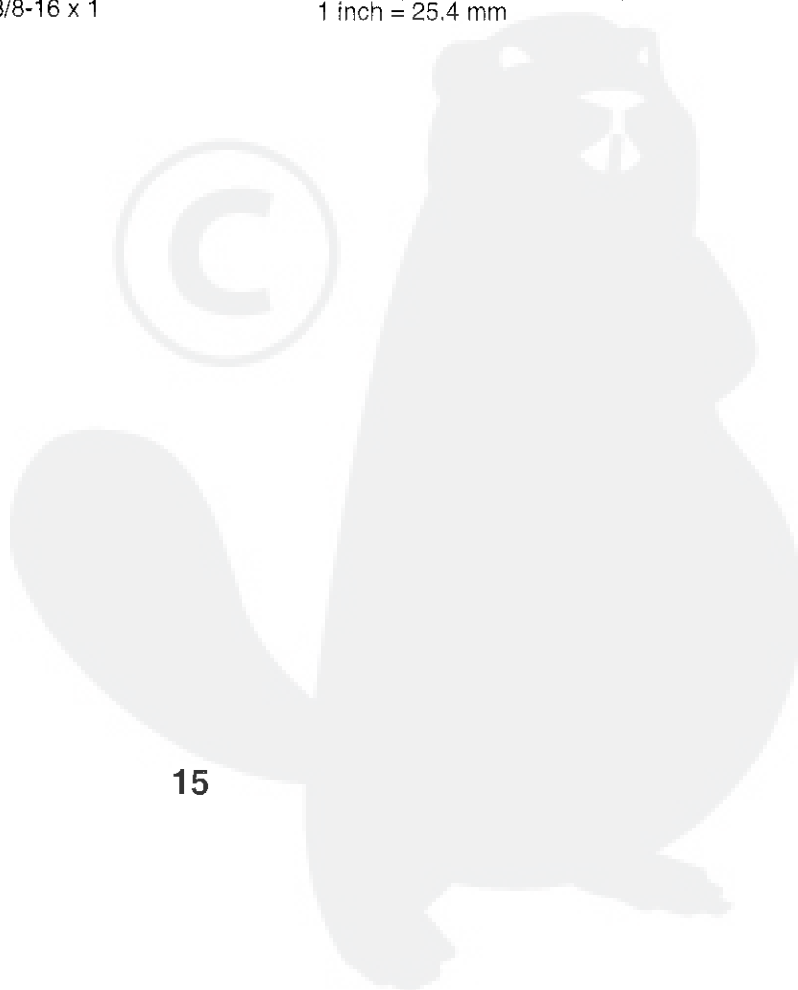

TRACTOR -- MODEL NUMBER 917.992310

LIFT ASSEMBLY

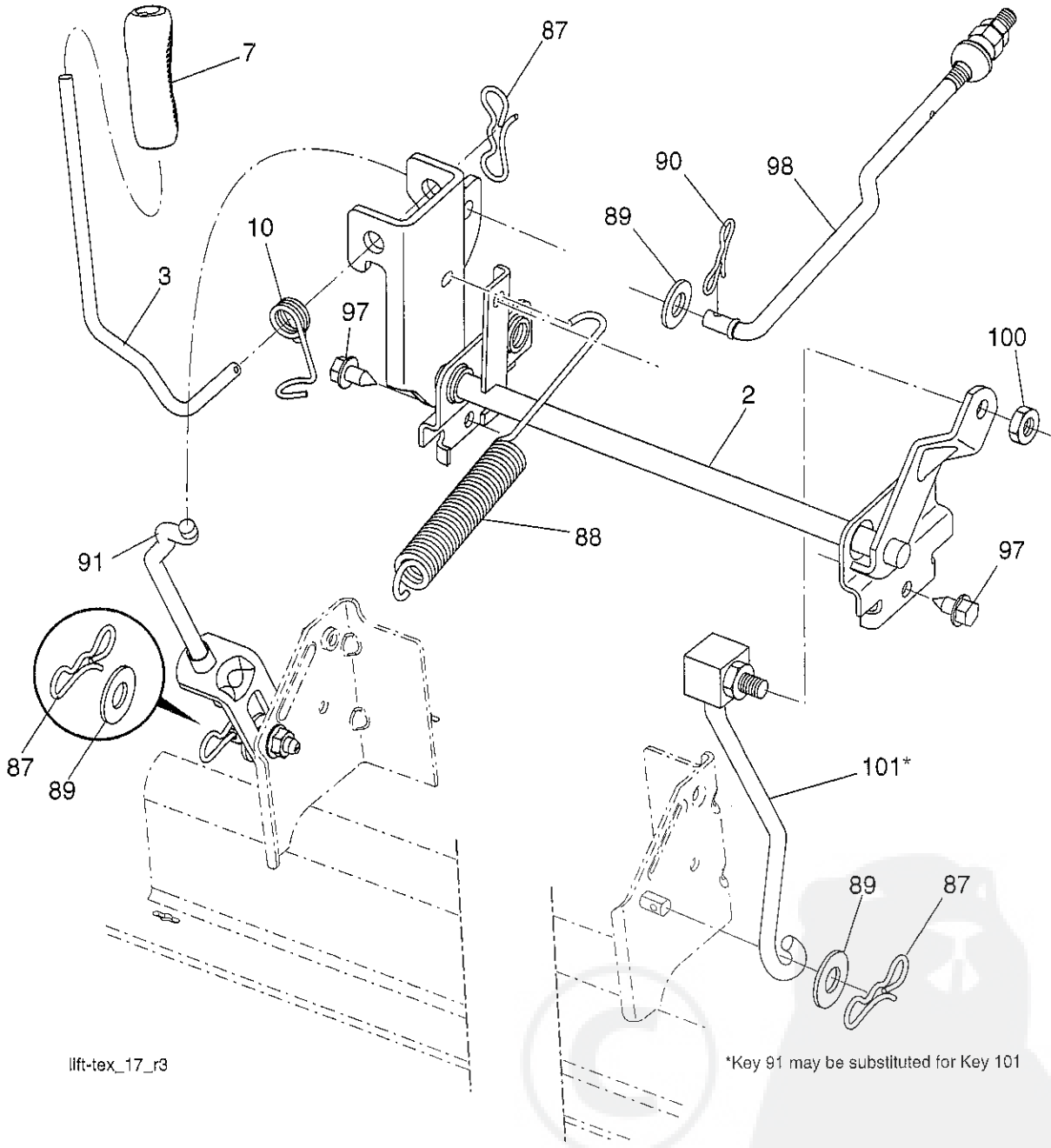

lift-tex_17_r3

*Key 91 may be substituted for Key 101

KEY NO.	PART NO.	DESCRIPTION
2	422027	Shaft Asm., Lift
3	195231	Lever Asm., Lift RH
7	196492X428	Grip, Lever
10	196314	Spring Torsion
87	194209	Pin Cotter 7/16 Bow Tie Lock
88	410710	Spring Lift Assist
89	19191912	Washer Clear Zinc
90	194208	Pin Cotter 5/16 Bow Tie Lock
91	195181	Link Lift Susp Mower Rear

KEY NO.	PART NO.	DESCRIPTION
97	17000612	Screw 3/8-16 x .75
98	195270	Link Lift Susp. Front Mower
100	73930600	Nut Centerlock 3/8-16 unc
101	407003	Link Asm Lift Fixed

NOTE: All component dimensions give in U.S. inches
1 inch = 25.4 mm

TRACTOR - - MODEL NUMBER 917.992310

DECALS

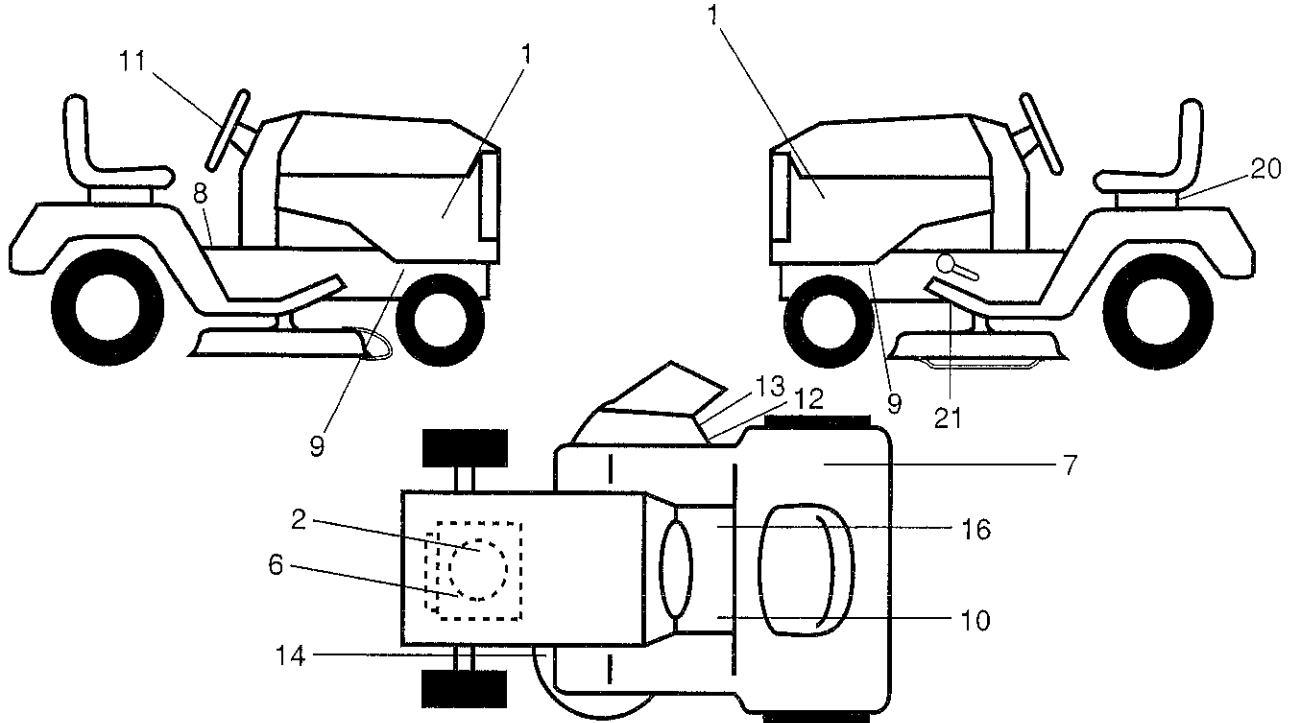

KEY NO.	PART NO.	DESCRIPTION
1	581744401	Decal Side Panel Logo
2	442933	Decal Eng. H.P.
6	581579701	Decal Warning Engine
7	581724101	Decal Certification
8	581578101	Decal Fender Warn
9	581579601	Decal Hot Muffler
10	581724001	Decal Brake/Clutch
11	439525	Decal Ins Strg Whl
12	581579201	Decal Warning
13	581579101	Decal Cutting CE
14	581580001	Decal V-Belt Schematic
16	581578001	Decal Saddle Brake Parking

KEY NO.	PART NO.	DESCRIPTION
20	145005	Decal Bat Dan/Psn
21	421534	Decal V-Belt Sch.
--	581724801	Decal Bypass Fender
--	193226X428	Pad Footrest LH
--	193227X428	Pad Footrest RH
--	581724601	Decal Drawbar Load Limit
--	581904140	Manual Oper. (Euro)
--	581904250	Manual Oper. (Scan)
--	581904320	Manual Oper. (E-Bloc)
--	581904430	Manual Oper. (Baltic)
--	581904527	Manual Parts (English)

WHEELS & TIRES

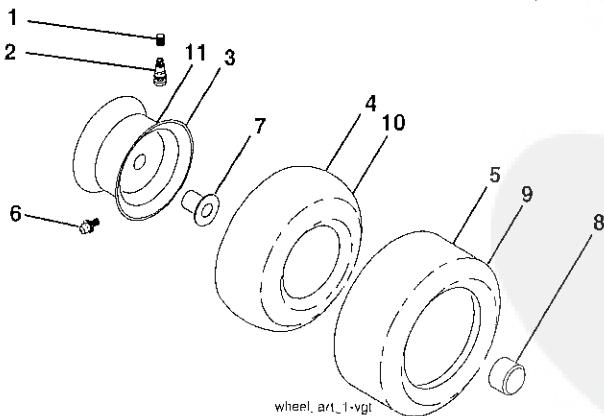

KEY NO.	PART NO.	DESCRIPTION
1	59192	Cap Valve Tire
2	65139	Stem Valve
3	106732X613	Rim Asm 6" Front
4	59904	Tube Front (Service Item Only)
5	106222X	Tire F T
6	278H	Fitting Grease (Front Wheel Only)
7	9040H	Bearing Flange (Front Wheel Only)
8	104757X428	Cap Axle Blk 1 50 x 1 00
9	138468	Tire R T
10	7152J	Tube Rear (Service Item Only)
11	106108X613	Rim Asm 8" Rear Service
--	144334	Sealant, Tire (10 oz. Tube)

NOTE: All component dimensions give in U.S. inches
1 inch = 25.4 mm

TRACTOR - - MODEL NUMBER 917.992310
TUFFTORK TRANSAXLE - MODEL NO. K46BA

MODEL K46BA
7A646084100

ACTUAL PARTS
MAY NOT APPEAR
AS SHOWN

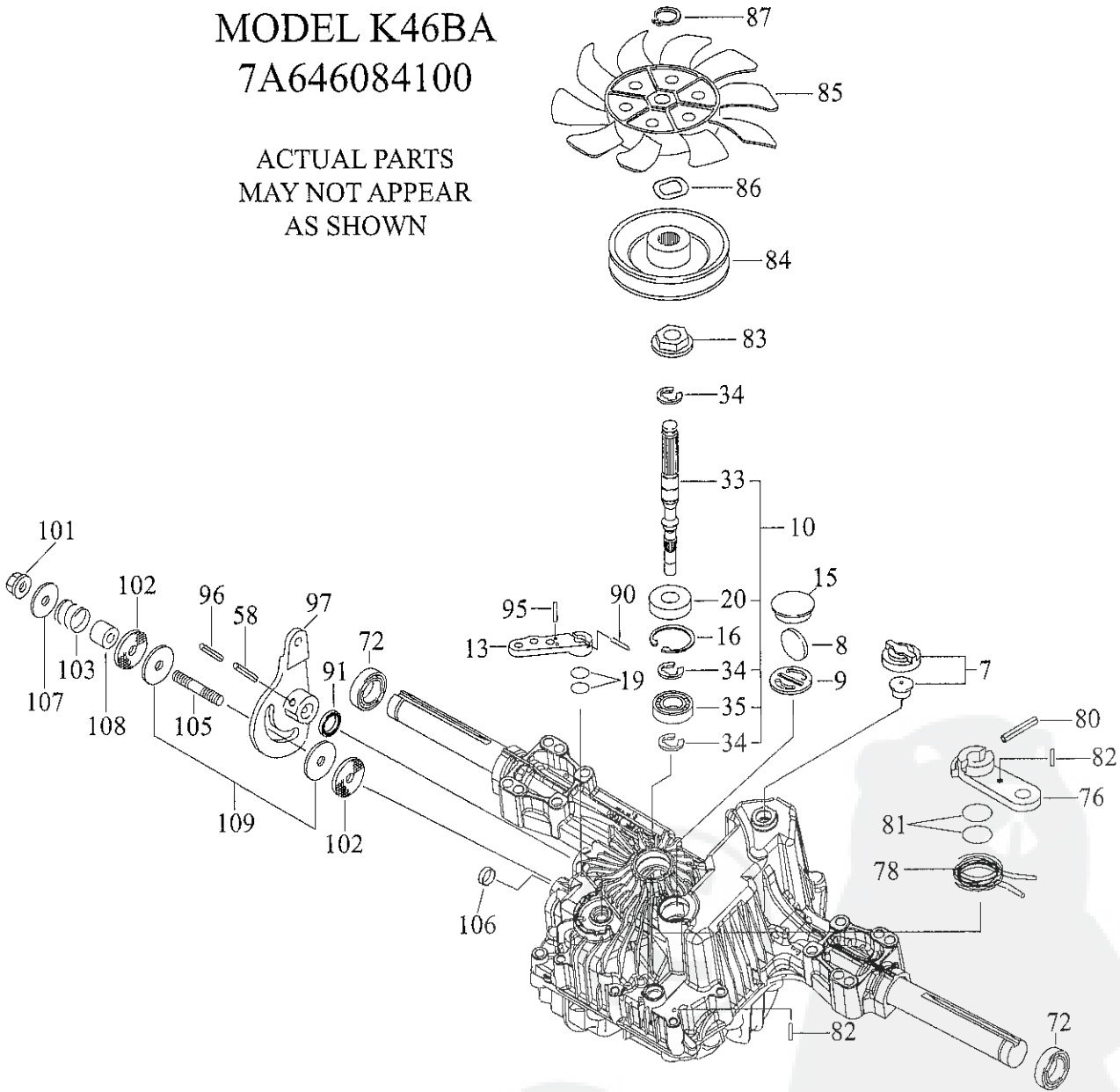

TRACTOR - - MODEL NUMBER 917.992310
TUFFTORK TRANSAXLE - MODEL NO. K46BA

KEY NO.	PART NO.	DESCRIPTION
7	414395	VENT VALVE 15
8	414396	MAGNET
9	414397	MAGNET HOLDER
10	415923	PUMP SHAFT/BEARING KIT
13	414398	BYPASS LEVER
15	414399	SEALING CAP 30
16	414400	SNAP RING C 35
19	414401	O-RING 1A P10A
20	414402	SEAL TC 153507
33	414403	PUMP SHAFT (STANDARD
34	414404	E-RING 15
35	414405	BEARING 6202C3
58	414406	ROLL PIN 6 * 40
72	414407	SEAL 19 * 32 * 8
76	414408	BRAKE LEVER
78	414409	BRAKE RETURN SPRING
80	414410	SPRING PIN 5 * 32
81	414411	O-RING 1A P12
82	414412	SPRING PIN 4 * 16
83	414413	SPINE COLLAR
84	414414	PULLEY L
85	414415	FAN, BLACK
86	414416	WAVE WASHER
87	414417	SNAP RING
90	414418	SPRING PIN 3.0A * 20
91	414419	OIL SEAL 16 * 22 * 03
95	415850	SPRING PIN 3.0A * 16
96	414420	ROLL PIN 3.5 * 40
97	414421	CONTROL LEVER
101	414216	LOCK NUT 10
102	414423	WASHER 10 * 40 * 4
103	414424	SPRING
105	414425	STUD 10 * 60
106	414426	SEALING CAP 18
107	414427	WASHER 10 * 36 * 2.8
108	414428	COLLAR 10 * 20 * 17
109	414429	FRICTION PLATE KIT

NOTE: All component dimensions give in U.S. inches
1 inch = 25.4 mm

TRACTOR - - MODEL NUMBER 917.992310

BRIGGS & STRATTON ENGINE-MODEL NUMBER 31P677, TYPE NUMBER 0156-B1

48 SHORT BLOCK | 1058 OPERATOR'S MANUAL | 1329 REPLACEMENT ENGINE | 1330 REPAIR MANUAL | 1036 EMISSIONS LABEL

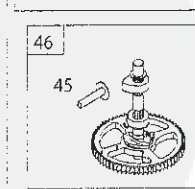
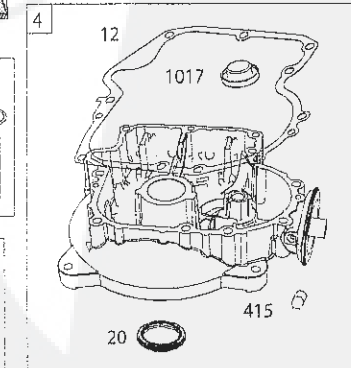
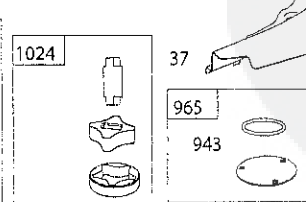
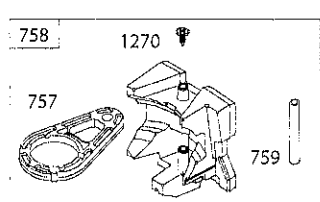
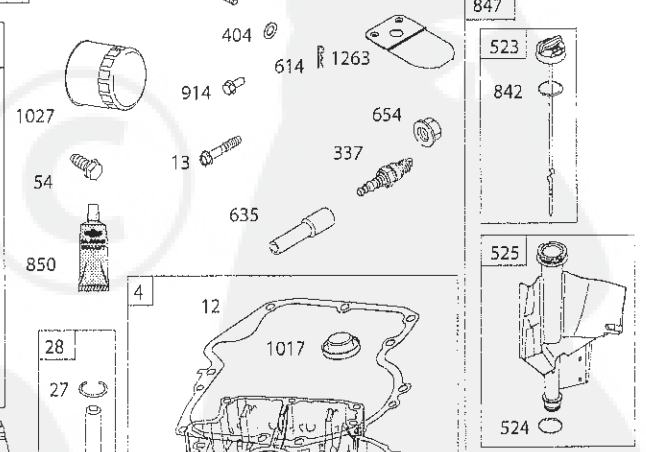
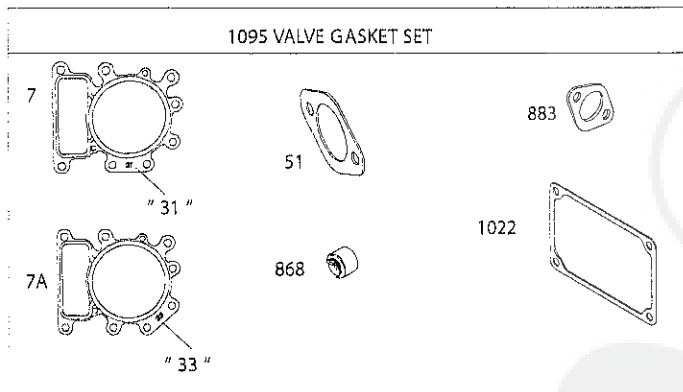
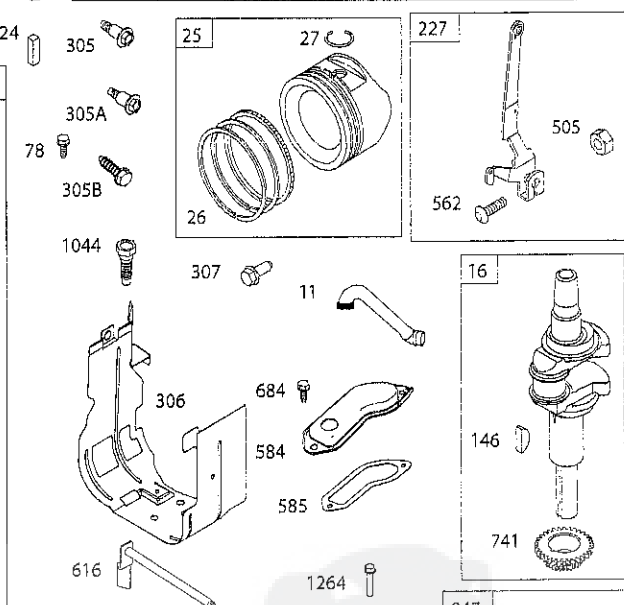
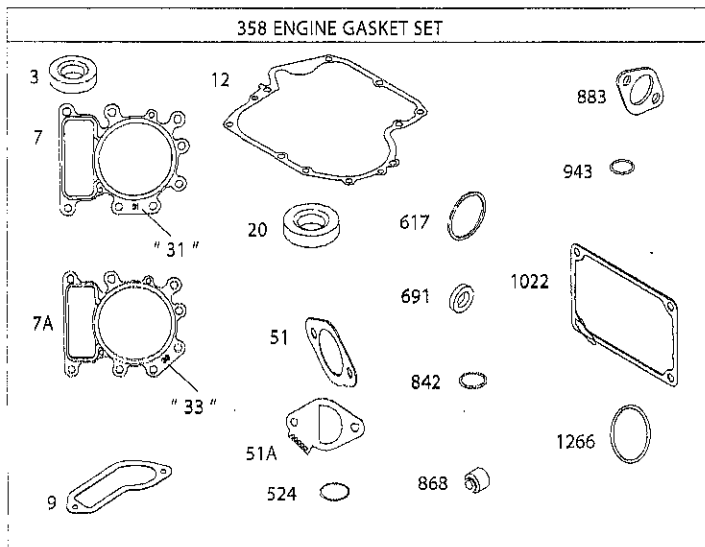
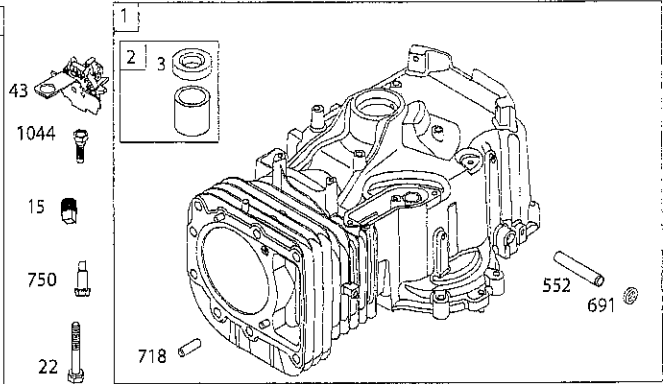
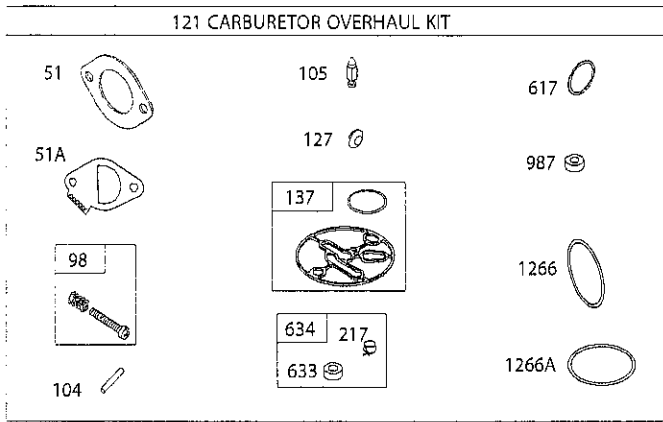

TRACTOR - - MODEL NUMBER 917.992310
BRIGGS & STRATTON ENGINE-MODEL NUMBER 31P677, TYPE NUMBER 0156-B1

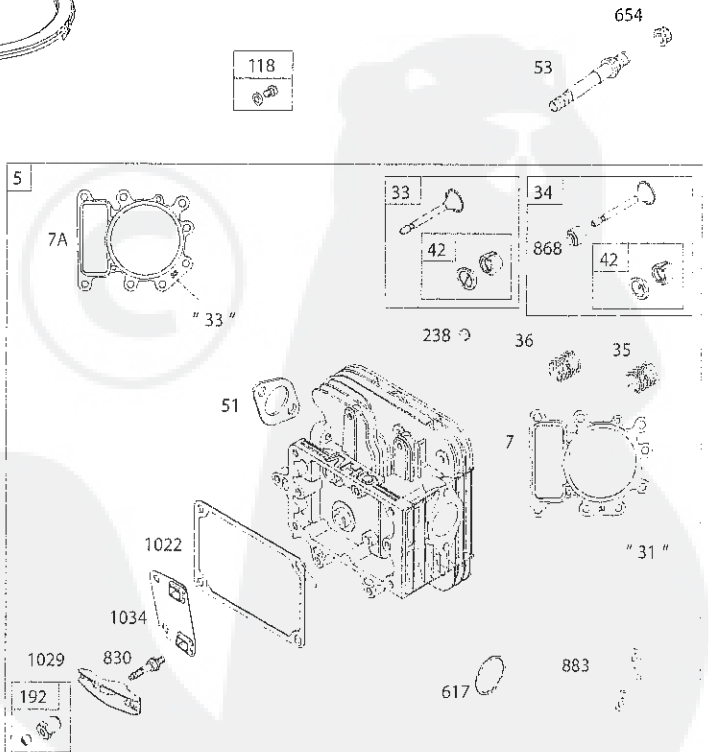
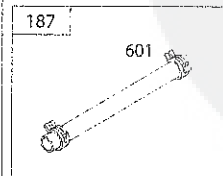
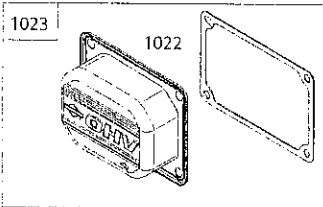
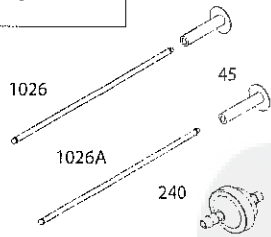
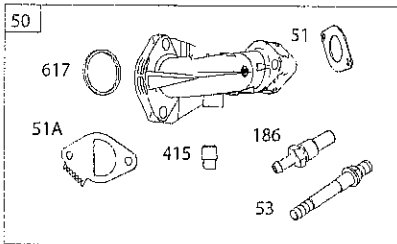
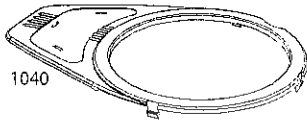
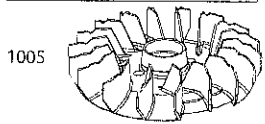
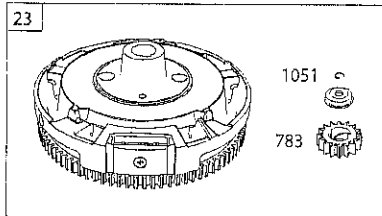
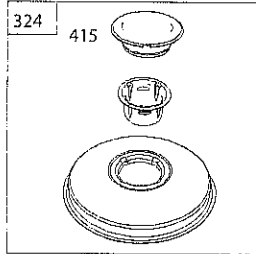
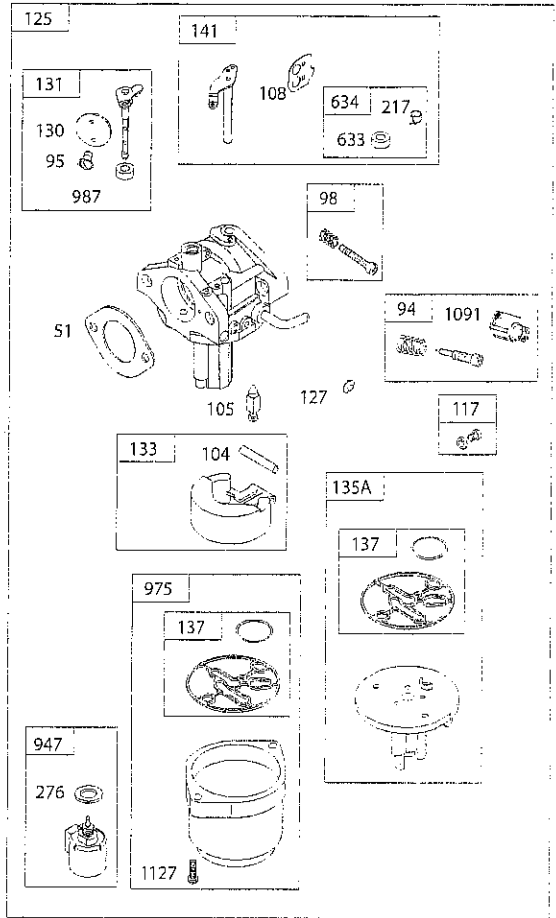
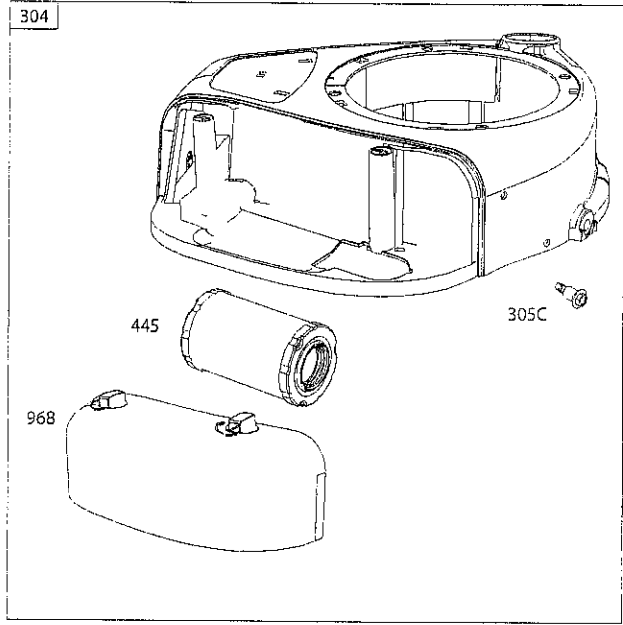

TRACTOR - - MODEL NUMBER 917.992310
BRIGGS & STRATTON ENGINE-MODEL NUMBER 31P677, TYPE NUMBER 0156-B1

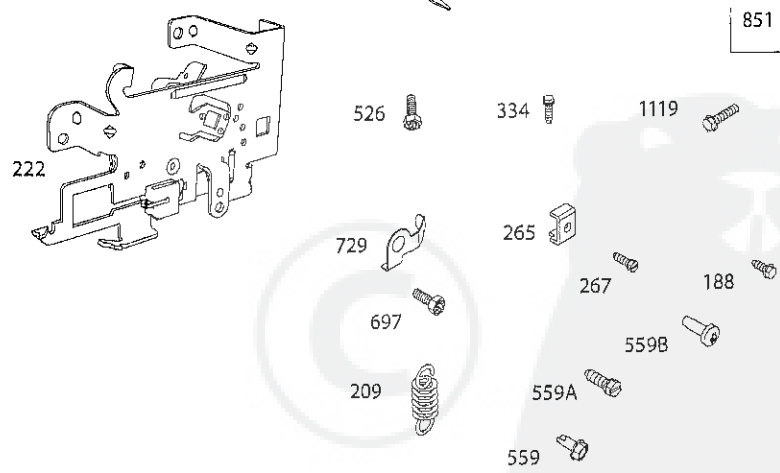
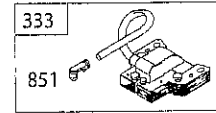
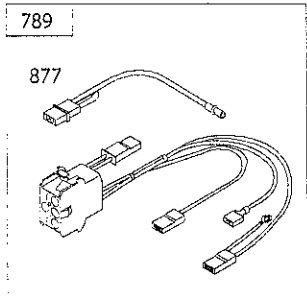
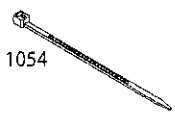
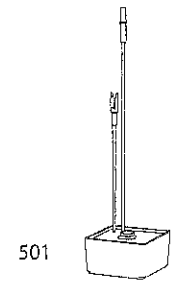
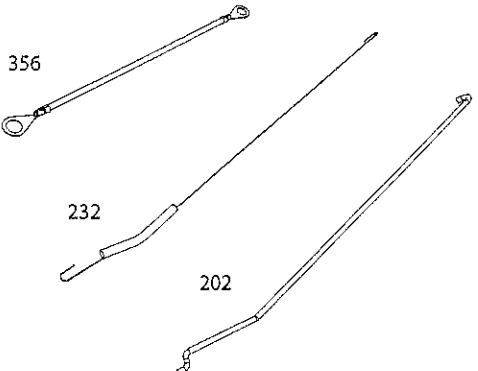
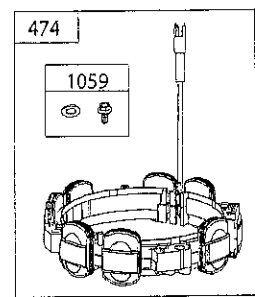
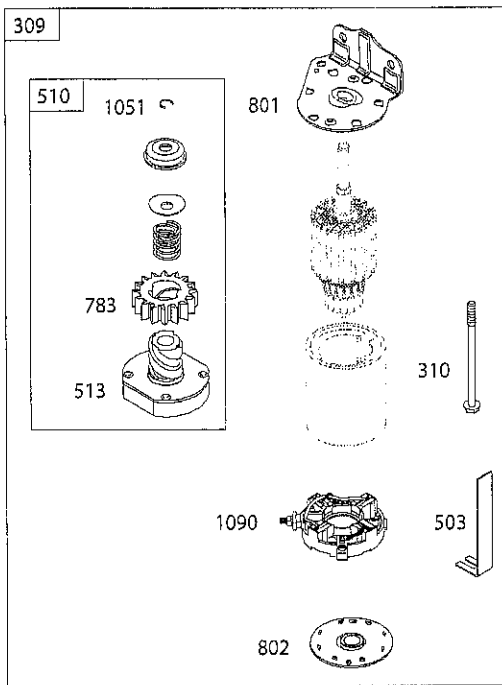
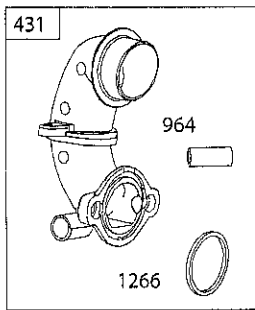
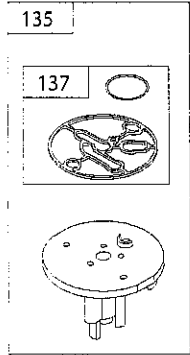

TRACTOR - - MODEL NUMBER 917.992310
BRIGGS & STRATTON ENGINE-MODEL NUMBER 31P677, TYPE NUMBER 0156-B1

KEY NO.	PART NO.	DESCRIPTION	KEY NO.	PART NO.	DESCRIPTION
1	796010	Cylinder Assembly	137	698781	Gasket-Float Bowl
2	797673	Kit-Bushing/Seal (Magneto Side)	141	792777	Kit-Choke Shaft
3	391086s	Seal-Oil (Magneto Side)	146	691639	Key-Timing
4	697188	Sump-Engine	186	794873	Connector-Hose (Intake Manifold)
5	796026	Head-Cylinder	187	791766	Line-Fuel (Cut to Required Length)
7	796584	Gasket-Cylinder Head			
7A	794114	Gasket-Cylinder Head	188	691693	Screw (Control Bracket)
11	794683	Tube-Breather	192	691986	Adjuster-Rocker Arm
12	697110	Gasket-Crankcase	202	691841	Link-Mechanical Governor
13	592244	Screw (Cylinder Head)	209	796260	Spring-Governor (Green)
15	690946	Plug-Oil Drain	217	695409	Spring-Choke Return
16	591763	Crankshaft	222	694042	Bracket-Control
20	795387	Seal-Oil (PTO Side)	227	691374	Lever-Governor Control
22	692125	Screw (Crankcase Cover/Sump)	232	691842	Spring-Governor Link
23	591758	Flywheel	238	691843	Cap-Valve
24	591757	Key-Flywheel (Steel)	240	394358s	Filter-Fuel
25	796172	Piston Assembly (Standard)	265	691024	Clamp-Casing
	796173	Piston Assembly (.020" Oversize)	267	794904	Screw (Casing Clamp)
26	791936	Ring Set (Standard)	276	695410	Washer-Sealing
	792649	Ring Set (.020" Oversize)	304	591642	Housing-Blower
27	698469	Lock-Piston Pin	305	697102	Screw (Blower Housing) (1/4-20x1.21)
28	796007	Pin-Piston			
29	794571	Rod-Connecting (Standard)	305A	793376	Screw (Blower Housing) (1/4-20x.82)
32	791118	Screw (Connecting Rod)			
33	792868	Valve-Exhaust	305B	795891	Screw (Blower Housing to Intake Elbow)
34	791935	Valve-Intake			
35	691279	Spring-Valve (Intake)	305C	799370	Screw (Blower Housing) (1/4-20x.90)
36	691279	Spring-Valve (Exhaust)			
37	697352	Guard-Flywheel	306	796006	Shield-Cylinder
42	499586	Retainer-Valve	307	691693	Screw (Cylinder Shield)
43	691968	Slinger-Governor/Oil	309	693551	Motor-Starter
45	690564	Tappet-Valve	310	690323	Bolt (Starter Motor)
46	793880	Camshaft	324	796308	Screen/Cup Assembly
48	N/A	Short Block (Not Available at this Printing)	333	799650	Armature-Magneto
			334	691061	Screw (Magneto Armature)
50	591248	Manifold-Intake	337	691043	Plug-Spark
51	692137	Gasket-Intake	356	697089	Wire-Stop
51A	796081	Gasket-Intake (Restrictor)	358	796187	Gasket Set-Engine
53	591260	Stud (Carburetor)	404	691691	Washer (Governor Crank)
54	691148	Screw (Intake Manifold)	415	794129	Plug (Cover/Retainer)
78	691693	Screw (Flywheel Guard)	415A	794903	Plug (Intake Manifold)
94	793610	Kit-Idle Mixture	431	797901	Elbow-Intake
95	690718	Screw (Throttle Valve)	445	796031	Filter-Air Cleaner Cartridge
98	695408	Kit-Idle Speed	474	696457	Alternator
104	694918	Pin-Float Hinge	501	794360	Regulator
105	696136	Valve-Float Needle	503	691532	Strap-Starter
108	695419	Valve-Choke	505	691251	Nut (Governor Control Lever)
117	699773	Jet-Main (Standard)	510	693699	Drive-Starter
118	843099	Jet-Main (High Altitude)	513	692024	Clutch-Drive
121	796184	Kit-Carburetor Overhaul	523	699908	Dipstick
125	591734	Carburetor	524	691032	Seal-Dipstick Tube
127	690727	Plug-Welch	525	697184	Tube-Dipstick
130	792747	Valve-Throttle	552	697144	Bushing-Governor Crank
131	792765	Kit-Throttle Shaft	559	697561	Screw (Remote Choke) (Control Bracket)
133	694914	Float-Carburetor			
135	698780	Tube-Fuel Transfer (O.E.M. Carburetor)	559A	693675	Screw (Remote Choke) (Control Bracket) (#8-32x.37)
135A	796400	Tube-Fuel Transfer (Service Carburetor)	559B	699891	Screw (Speed Limiter) (Control Bracket) (#8-32x.50)

TRACTOR - - MODEL NUMBER 917.992310

BRIGGS & STRATTON ENGINE-MODEL NUMBER 31P677, TYPE NUMBER 0156-B1

KEY NO.	PART NO.	DESCRIPTION	KEY NO.	PART NO.	DESCRIPTION
562	691119	Bolt (Governor Control Lever)	1058	276344TRI	Owner's Manual
584	794682	Cover-Breather Passage	1059	698516	Kit-Screw/Washer (Alternator)
585	697109	Gasket-Breather Passage	1090	691293	Retainer-Brush
601	791850	Clamp-Hose (Green)	1091	691333	Cap-Limiter
614	691620	Pin-Cotter (Governor Crank)	1095	794152	Gasket Set-Valve
616	692012	Crank-Governor	1119	691183	Screw (Alternator)
617	692138	Seal-O Ring (Intake Manifold) (Red)	1127	695407	Screw (Float Bowl)
633	699813	Seal-Choke/Throttle (Choke Shaft)	1263	697124	Reed-Breather
634	698779	Spring/Seal Assembly (Choke Shaft)	1264	697104	Screw (Breather Reed)
635	691909	Boot-Spark Plug	1266	691917	Seal-O Ring (Intake Elbow) (Red)
654	690958	Nut (Carburetor)	1270	793243	Plug-AVS Counterweight
684	697157	Screw (Breather Passage Cover)	1329	N/A	Replacement Engine (Not Available At This Printing)
691	692407	Seal-Governor Shaft	1330	N/A	Repair Manual (Not Available At This Printing)
697	791680	Screw (Drive Cap)			
718	690959	Pin-Locating			
729	691224	Clip-Wire			
741	697128	Gear-Timing			
750	790832	Screw (Oil Pump Cover)			
757	793242	Link-Counterweight			
758	793763	Counterweight			
759	697392	Pin-Counterweight			
783	693713	Gear-Pinion			
789	698329	Harness-Wiring			
801	691283	Cap-Drive			
802	691286	Cap-End			
830	691095	Stud (Rocker Arm)			
842	691031	Seal-O Ring (Dipstick Tube)			
847	790442	Dipstick/Tube Assembly			
850	100106	Sealant-Liquid			
851	692424	Terminal-Spark Plug			
868	690968	Seal-Valve			
877	790544	Wire/Connector-Alternator			
883	692236	Gasket-Exhaust			
914	697551	Screw (Rocker Cover)			
943	690589	Seal-O Ring (Oil Pump Cover)			
947	699915	Solenoid-Fuel			
964	799159	Cap-Connector (EVAP System)			
965	499613	Cover-Oil Pump			
968	591647	Cover-Air Cleaner			
975	699502	Bowl-Float			
987	698777	Seal-Throttle Shaft			
1005	796083	Fan-Flywheel			
1017	796981	Screen-Oil Pump			
1022	272475s	Gasket-Rocker Cover			
1023	797421	Cover-Rocker Arm			
1024	794644	Pump-Oil			
1026	692003	Rod-Push (Intake)			
1026A	692011	Rod-Push (Exhaust)			
1027	795890	Filter-Oil			
1029	691751	Arm-Rocker			
1034	690822	Guide-Push Rod			
1036		Label-Emissions (Available from a Briggs & Stratton Authorized Dealer)			
1040	699852	Plate-Trim			
1044	698139	Screw (Flywheel)			
1051	691265	Ring-Retaining			
1054	280275	Tie-Cable			

Carburetor Overhaul Kit Key Key No. 121
 Engine Gasket Set Key No. 358
 Valve Gasket Set Key No. 1095

NOTE: All component dimensions given in U.S. inches
 1 inch = 25.4 mm

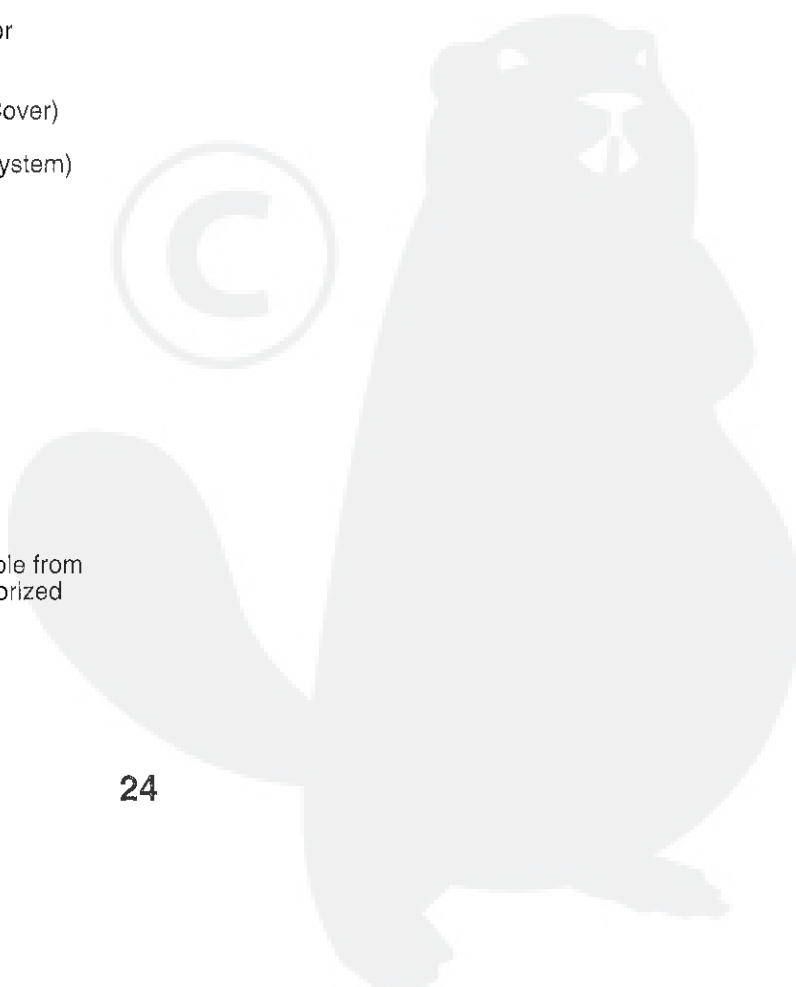

SERVICE NOTES

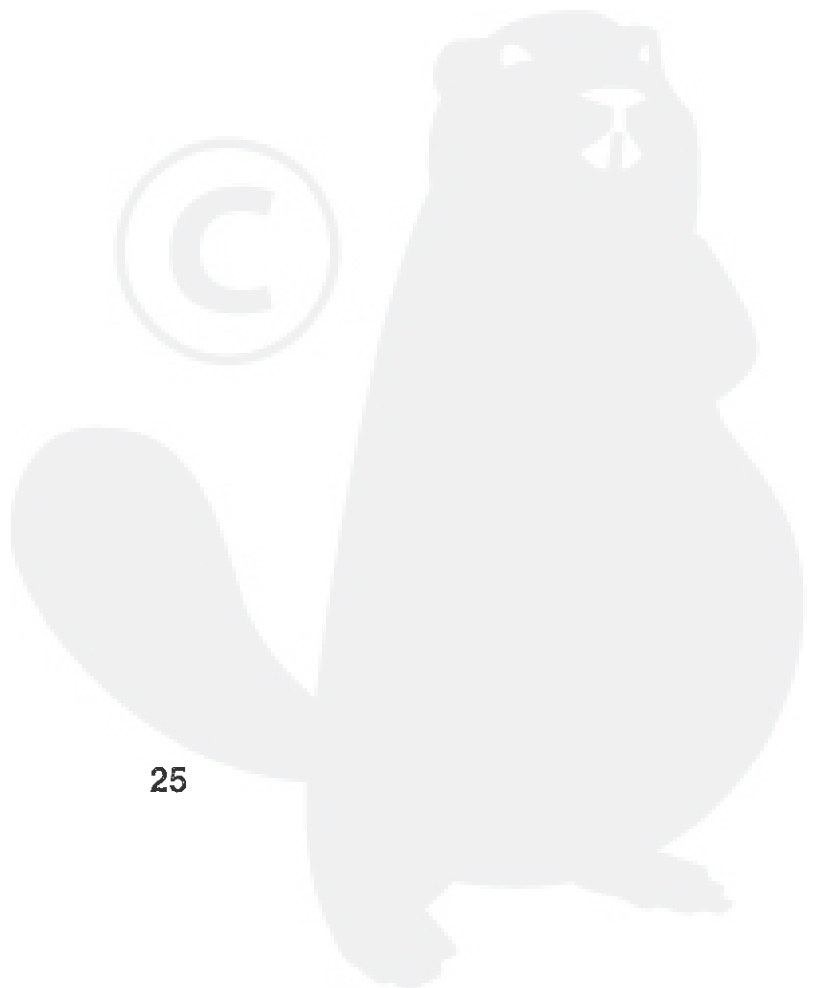
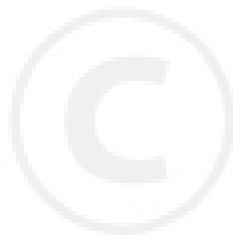

SERVICE NOTES

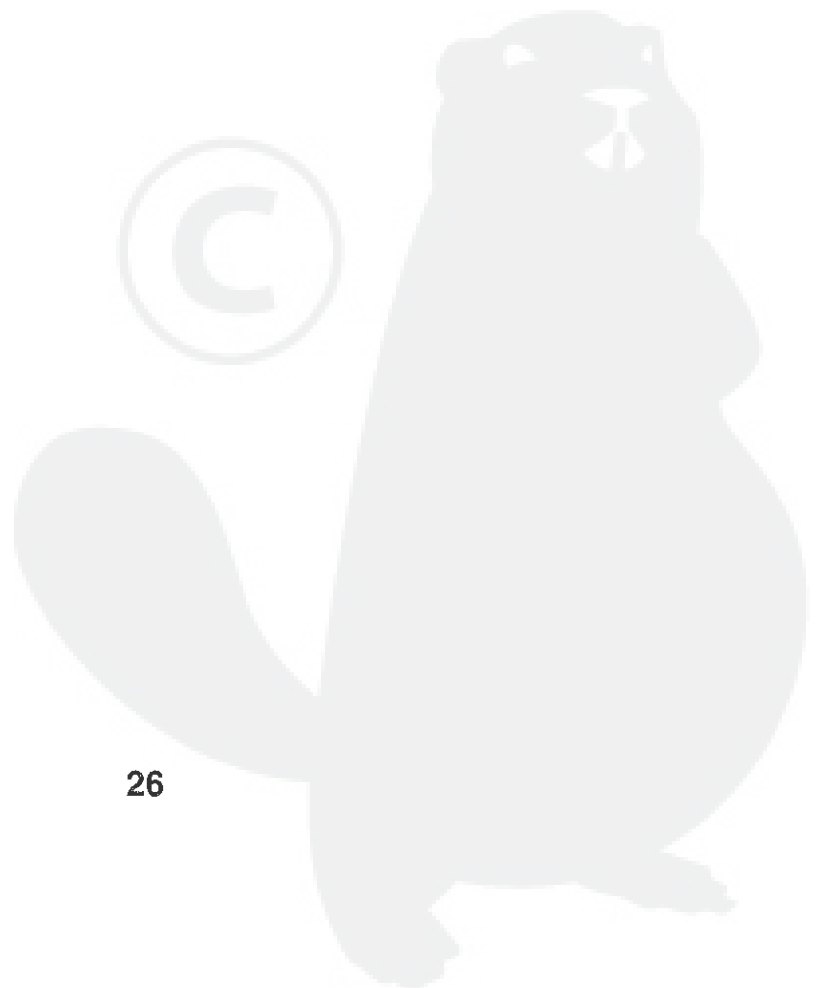

SERVICE NOTES

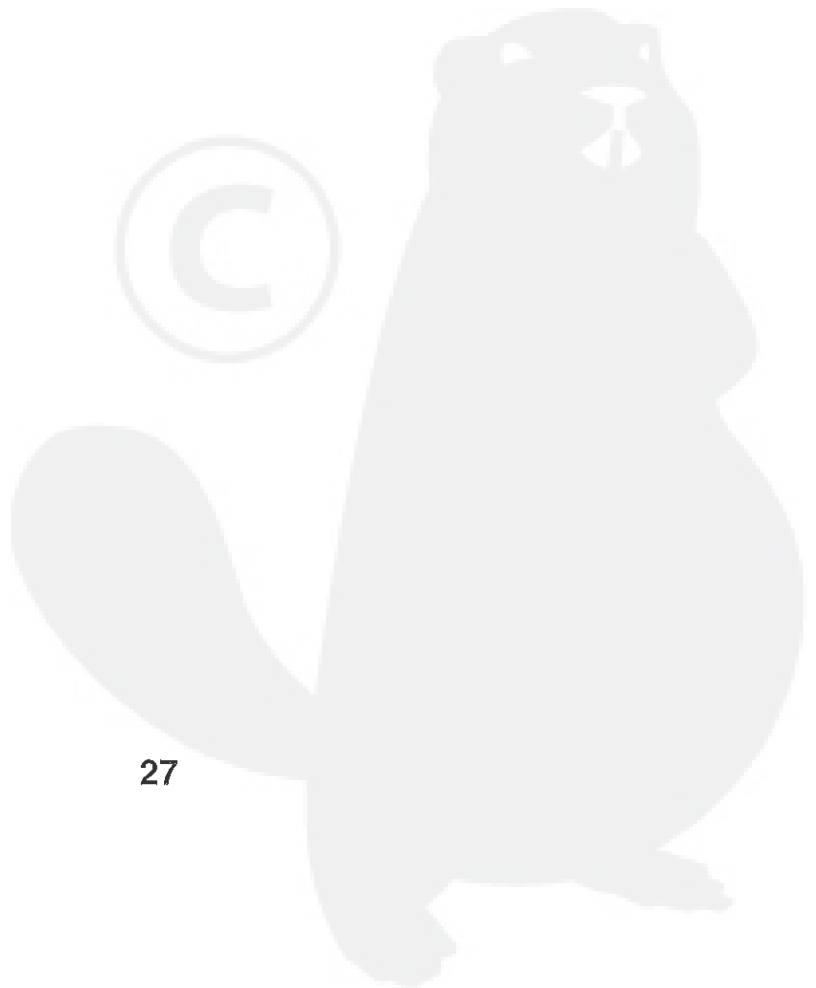
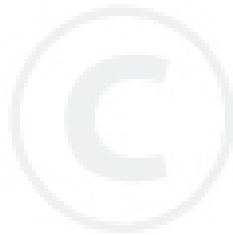

LIMITED WARRANTY ON CRAFTSMAN RIDING EQUIPMENT

For two (2) years from the date of purchase, if this Craftsman Riding Equipment is maintained, lubricated and tuned up according to the instructions in the owner's manual, Sears will repair or replace free of charge any parts that are found to be defective in material or workmanship according to the guidelines of coverage listed below. Sears will also provide free labor for these applicable warranted parts for the two full years. During the first 30 days of purchase, there will be no charges to service the product at your home for issues covered by this warranty. (See exclusions below). For your convenience, IN HOME warranty service will still be available after the first 30 days of purchase, but a trip charge will apply. This charge will be waived if the Craftsman product is dropped off at an authorized Sears location. For the nearest authorized Sears location, please call 1-800-4-MY-HOME®. This warranty applies only while this product is within the United States.

This Warranty does not cover:

- Expendable items which become worn during normal use, including but not limited to blades, spark plugs, air cleaners, belts, and oil filters.
- Standard Maintenance Servicing, oil changes, or tune-ups
- Tire replacement or repair caused by punctures from outside objects, such as nails, thorns, stumps, or glass.
- Repairs necessary because of operator abuse, including but not limited to, damage caused by towing objects beyond the capability of the riding equipment, impacting objects that bend the frame or crankshaft, or over-speeding the engine.
- Repairs necessary because of operator negligence, including but not limited to, electrical and mechanical damage caused by improper storage, failure to use the proper grade and amount of engine oil, failure to keep the deck clear of flammable debris, or failure to maintain the equipment according to the instructions contained in the owner's manual.
- Engine (fuel system) cleaning or repairs caused by fuel determined to be contaminated or oxidized (stale). In general, fuel should be used within 30 days of its purchase date.
- Normal deterioration and wear of the exterior finishes, or product label replacement.
- Riding equipment used for commercial or rental purposes.

LIMITED WARRANTY ON BATTERY

For ninety (90) days from date of purchase, if any battery included with this riding equipment proves defective in material or workmanship and our testing determines the battery will not hold a charge, Sears will replace the battery at no charge. During the first 30 days of purchase, there will be no charges to replace the battery at your HOME. After the first 30 days, for your convenience, IN-HOME warranty service will still be available but a trip charge will apply. This charge will be waived if the Craftsman product is dropped off at an authorized Sears location. For the nearest authorized Sears location, please call 1-800-4-MY-HOME®.

This battery warranty applies only while this product is within the United States.

This warranty gives you specific legal rights, and you may also have other rights, which vary, from state to state.

Sears Brands Management Corporation, Dept.817WA, Hoffman Estates, IL 60179

