

**REPAIR PARTS MANUAL**  
**MODEL NO. 253210**  
**Lawn Tractor**

**CRAFTSMAN<sup>®</sup>**

# HOW TO USE THIS MANUAL

This manual is designed to provide the customer with a means to identify the parts on his/her tractor when ordering repair parts. The illustrations may or may not represent the actual assemblies; therefore, it is not recommended to use this manual as a guide to assemble or disassemble the tractor. Some hardware and parts are drawn larger in order to more readily identify them.

Each tractor has its own model number.

The model number for your tractor can be found on the fender under the seat.

When ordering parts, always give the following information:

- Product - Lawn Tractor
- MODEL NUMBER - 253210
- Part Number
- Part Description

## TABLE OF CONTENTS

SCHEMATIC .....	3
ELECTRICAL.....	4-5
CHASSIS .....	6-7
DRIVE.....	8-9
ENGINE.....	10-11
STEERING .....	12
SEAT .....	13
MOWER DECK .....	14-15
DECALS.....	16
MOWER LIFT.....	17
TRANSAXLE BREAKDOWN .....	18-19
ENGINE BREAKDOWN.....	20-25
WARRANTY.....	BACK COVER

# TRACTOR -- MODEL NUMBER 917.253210

## SCHEMATIC

SCH03

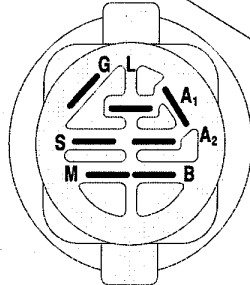
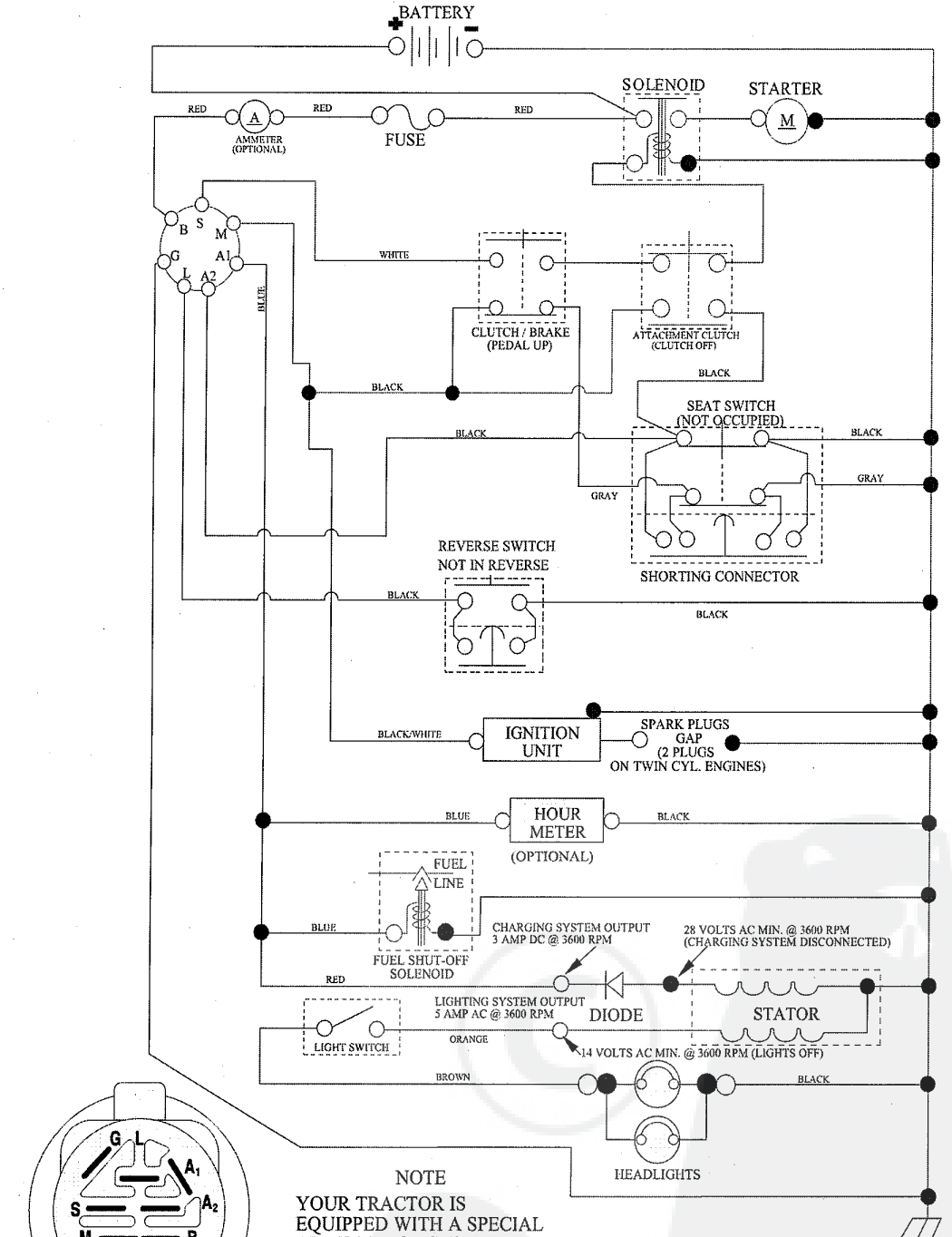

IGNITION SWITCH

POSITION	CIRCUIT	"MAKE"
OFF	M+G+A1	
RUN/OVERRIDE	B+A1	
RUN	B+A1	L+A2
START	B+S+A1	

**NOTE**  
 YOUR TRACTOR IS EQUIPPED WITH A SPECIAL ALTERNATOR SYSTEM. THE LIGHTS ARE NOT CONNECTED TO THE BATTERY, BUT HAVE THEIR OWN ELECTRICAL SOURCE. BECAUSE OF THIS, THE BRIGHTNESS OF THE LIGHTS WILL CHANGE WITH ENGINE SPEED. AT IDLE THE LIGHTS WILL DIM. AS THE ENGINE IS SPEEDED UP, THE LIGHTS WILL BECOME THEIR BRIGHTEST.



**WIRING INSULATED CLIPS**  
 NOTE: IF WIRING INSULATED CLIPS WERE REMOVED FOR SERVICING OF UNIT, THEY SHOULD BE RE-INSTALLED TO PROPERLY SECURE YOUR WIRING.

TRACTOR -- MODEL NUMBER 917.253210

ELECTRICAL

L02

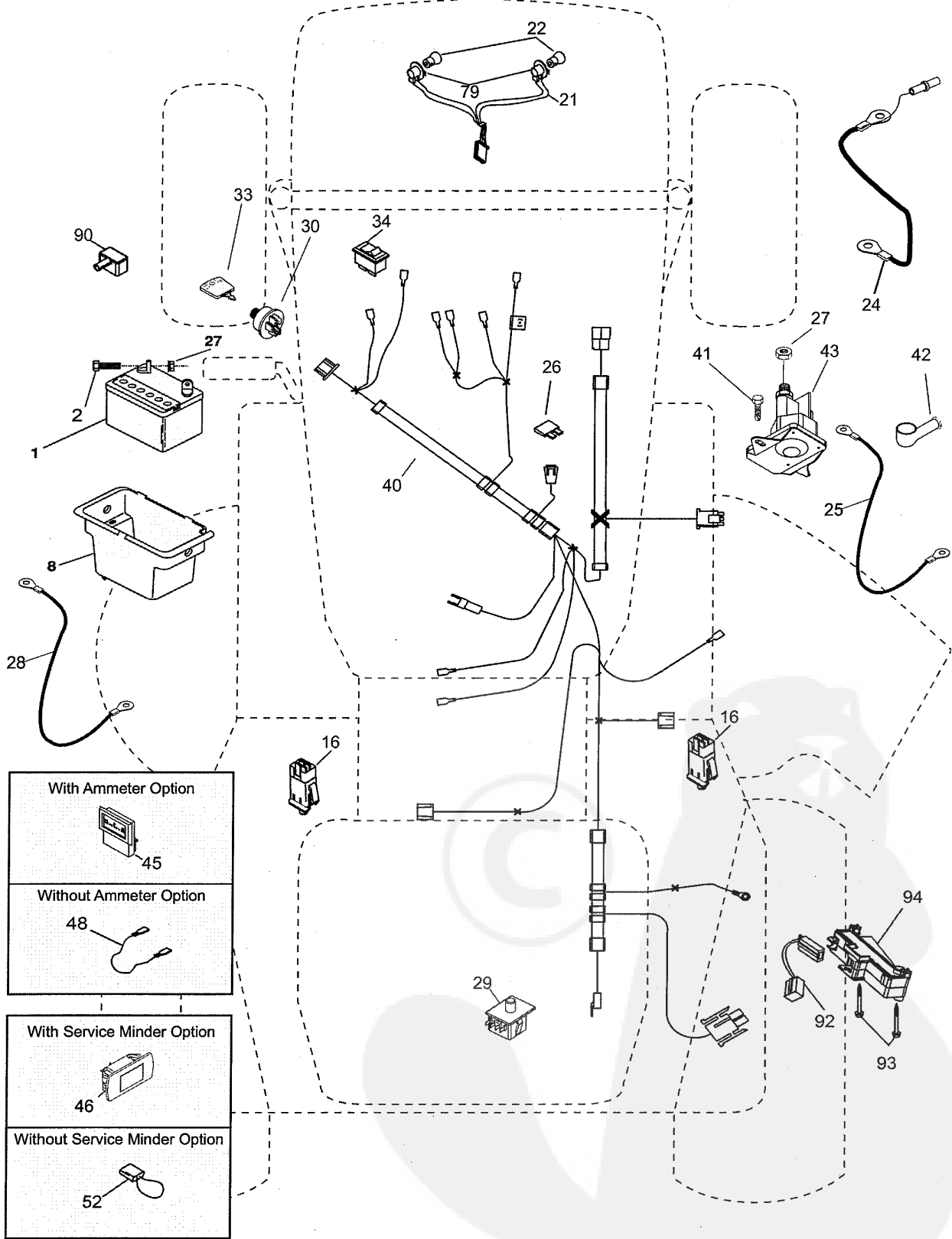

**TRACTOR - - MODEL NUMBER 917.253210**

**ELECTRICAL**

<b>KEY NO.</b>	<b>PART NO.</b>	<b>DESCRIPTION</b>
1	163465	Battery
2	74760412	Bolt Hex Hd 1/4-20 unc x 3/4
8	176689	Box Battery Fender
16	176138	Switch, Interlock
21	175688	Harness Asm Light w/4152j
22	4152J	Bulb Light #1156
24	4799J	Cable Battery 6 Ga. 11" Red
25	146147	Cable Battery 6 Ga. w/16 Wire Red
26	175158	Fuse 20 AMP
27	73510400	Nut, Keps Hex 1/4-20 unc
28	4207J	Cable Ground 6 Ga. 12" Black
29	192749	Switch Seat
30	193350	Switch Ign
33	411932	Key/Chain
34	110712X	Switch Light
40	197428	Harness Ign
41	71110408	Bolt Blk. Fin Hex 1/4-20 unc x 1/2
42	131563	Cover Terminal Red
43	192507	Solenoid
48	140844	Adapter Ammeter
52	141940	Protection Wire Loop
79	175242	Socket Asm. Bulb
90	180449	Cover Battery Terminal
92	196615	Harness Pigtail Reverse Switch
93	192540	Screw Plastic 10-14 x 2.0
94	191834	Module Reverse ROS

**NOTE:** All component dimensions given in U.S. inches  
1 inch = 25.4 mm

# TRACTOR -- MODEL NUMBER 917.253210

## CHASSIS ASSEMBLY

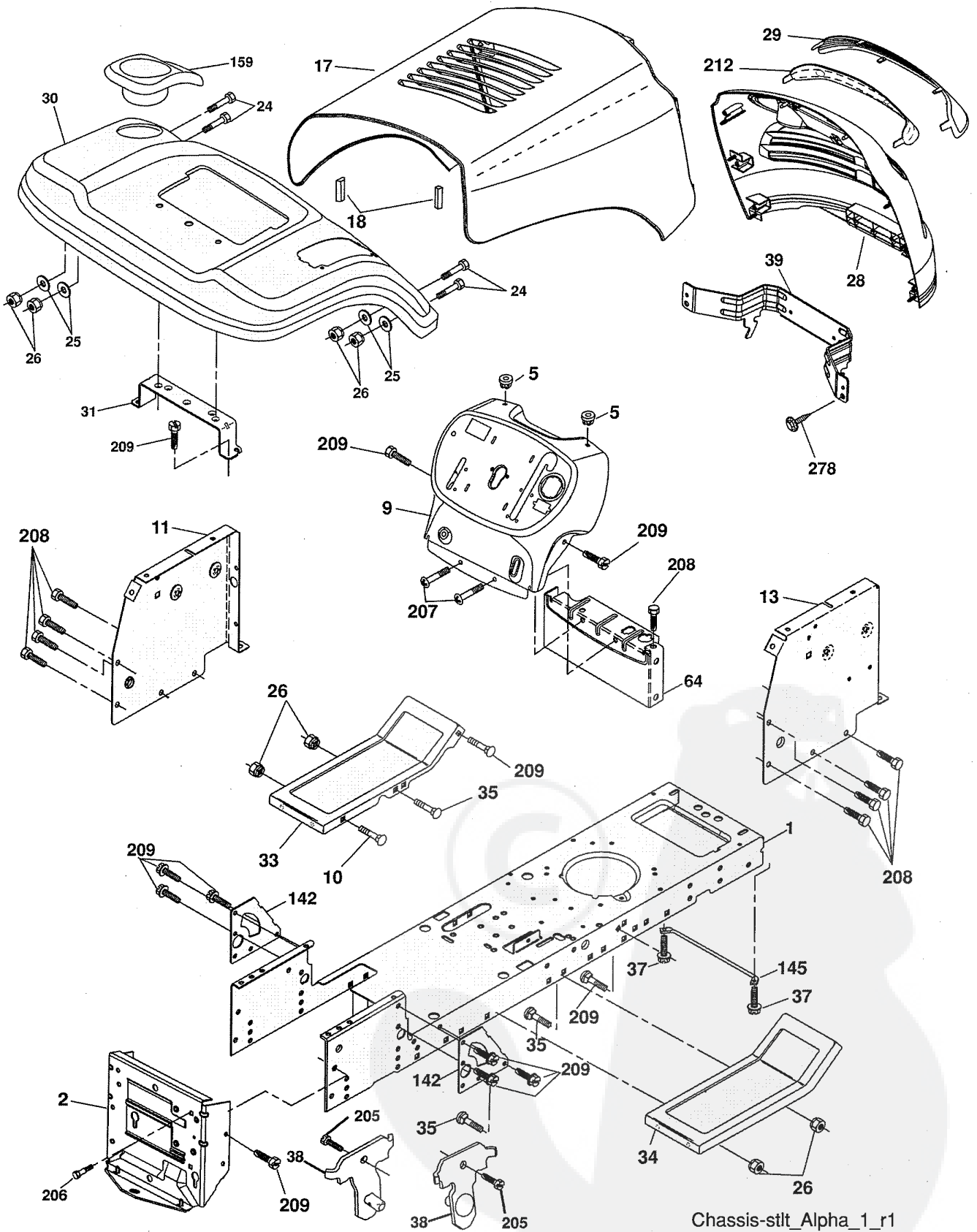

Chassis-stlt\_Alpha\_1\_r1

**CHASSIS ASSEMBLY****TRACTOR - - MODEL NUMBER 917.253210**

<b>KEY NO.</b>	<b>PART NO.</b>	<b>DESCRIPTION</b>
1	174619	Chassis Stamping
2	176554	Drawbar
5	155272	Bumper Hood/Dash
9	193510X013	Dash
10	STD533710	Bolt, Carriage 3/8-16 x 1
11	174996	Panel, Dash, L.H.
13	172105X010	Panel, Dash, R.H.
17	187559x613	Hood Assembly
18	184921	Bumper Hood Large 1.75
24	STD523710	Bolt Fin Hex 3/8-16 unc x 1 Gr. 5
25	19131312	Washer 13/32 x 13/16 x 12 Ga.
26	STD541437	Nut
28	187598	Grille Lens Asm
29	187567x599	Lens, Laser
30	192528X613	Fend/Ftrest Pnt STLT
31	136619	Bracket, Fender Support
33	179716X613	Footrest LH
34	179717X613	Footrest RH
35	STD533707	Bolt Rdhd Sht Sqnk 3/8-16 x 3/4
37	17490508	Screw Thdrol 5/16-18 x 1/2 Tyt
38	175710	Bracket Asm. Pivot Mower Rear
39	187568	Bracket Pivot Laser
64	154798	Dash Lower STLT
142	175702	Plate Reinforcement STLT
145	409167	Rod Pivot /Hood
159	169473X428	Cupholder
205	17490608	Screw Thdrol 3/8-16 x 1/2
206	170165	Bolt Shoulder 5/16 -18 TT
207	17670508	Screw Thdrol 5/16-18 x 1/2 TYTT
208	17670608	Screw Thdrol 3/8-16 x 1/2
209	17000612	Screw Hex Wsh Thdr 3/8-16 x 3/4
212	187569	Insert Lens Reflective
278	416358	Screw 10 x .750 BOS Thread
--	5479J	Plug, Button
--	187801	Plug Dome Plastic

**NOTE:** All component dimensions given in U.S. inches  
1 inch = 25.4 mm

# TRACTOR -- MODEL NUMBER 917.253210

## GROUND DRIVE

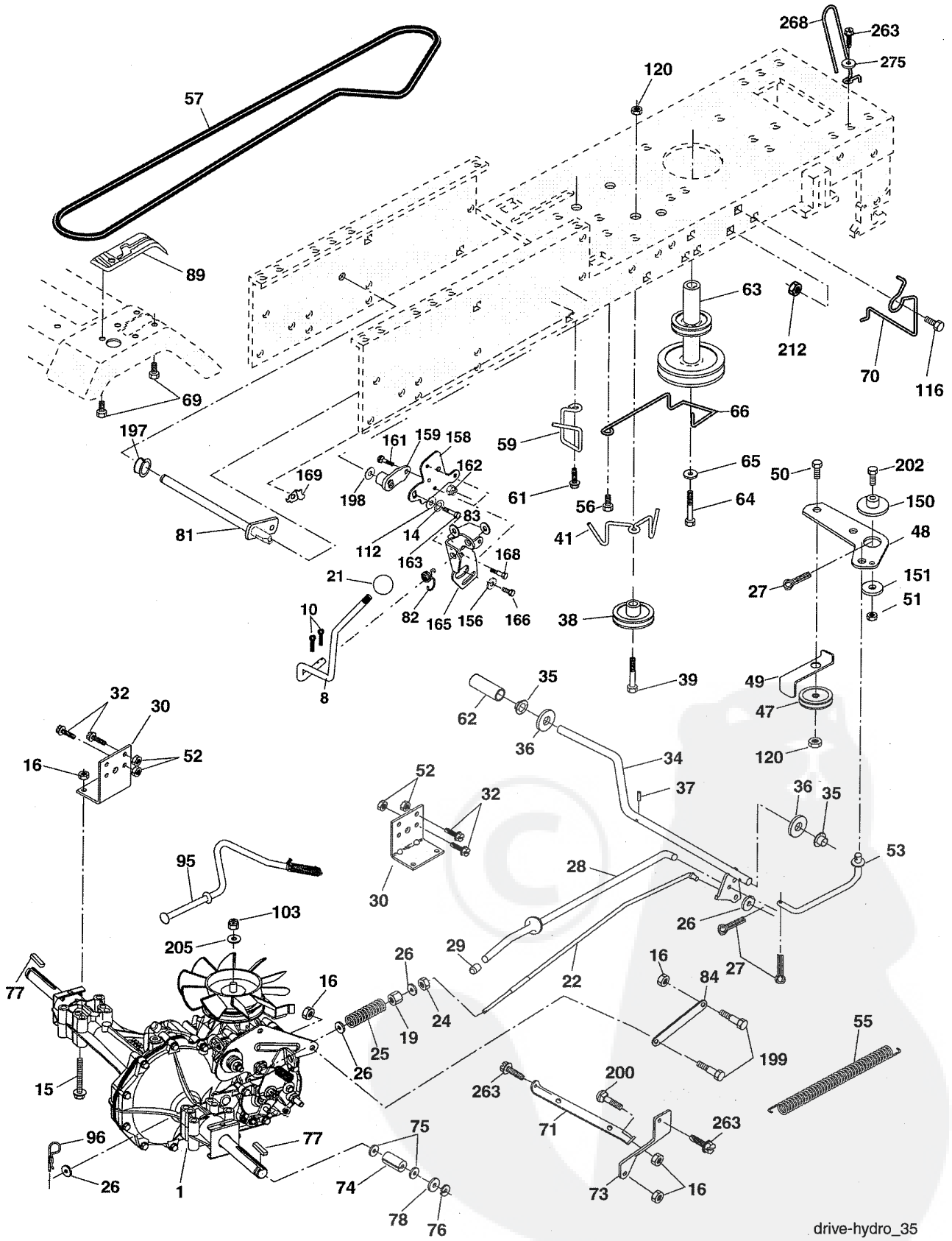

drive-hydro\_35



## TRACTOR - - MODEL NUMBER 917.253210

### GROUND DRIVE

KEY NO.	PART NO.	DESCRIPTION	KEY NO.	PART NO.	DESCRIPTION
1	-----	Transaxle Hydro Gear Model 322-0510 (Order parts from transaxle manufacturer)	71	169183	Strap Torque, LH
			73	169182	Strap Torque, RH
8	192706	Rod Shift	74	137057	Spacer Axle
10	76020416	Pin Cotter 1/8 X 1	75	121749X	Washer 25/32 x 1 1/4 x 16 Ga.
14	10040400	Washer Lock 1/4	76	12000001	Ring, E
15	74490544	Bolt Hex FLGHD 5/16-18 Gr. 5 unc	77	123583X	Key Square
16	73800500	Nut Lock Hex w/ins 5/16-18 unc	78	121748X	Washer 25/32 x 1-5/8 x 16 Ga.
19	73800600	Nut Lock Hex w/wsh 3/8-16 unc	81	165596	Shaft Asm Cross
21	140845	Knob	82	165711	Spring Torsion
22	169498	Rod Brake	83	19171216	Washer 17/32 x 3/4 x 16 Ga.
24	73350600	Nut	84	169843	Link Transaxle
25	106888X	Spring Rod Brake	89	192056X428	Console Shift
26	19131316	Washer 13/32 x 13/16 x 16 Ga.	95	170201	Control Asm Bypass Hydro
27	76020412	Pin Cotter 1/8 x 3/4	96	4497H	Retainer Spring 1"
28	175765	Rod Brake Parking	103	73940800	Nut, Hex Jam Top Lock 1/2-20 unf
29	71673	Cap Brake Parking	112	19091210	Washer 9/32 x 3/4 x 10 Ga.
30	174973	Bracket Transmission	116	72140608	Bolt 3/8-16 x 1
32	74760512	Bolt Hex Hd 5/16-18 unc x 3/4	120	73900600	Bolt Hex 3/8-16 x 1-1/2
34	175578	Shaft Foot Pedal	150	175456	Spacer Retainer
35	120183X	Bearing Nylon	151	19133210	Washer 13/32 x 2 x 10
36	19211616	Washer	156	166002	Washer 5/16 x 1.0 x 1.25
37	1572H	Pin Roll	158	165589	Bracket Shift Mount
38	179114	Pulley Idler Composite	159	183900	Hub Tapered Flange Shift
39	72110622	Bolt	161	72140406	Bolt Rdhd Sqnk 1/4-20 x 3/4 Gr. 5
41	175556	Keeper Belt Idler	162	73680400	Nut Crownlock 1/4-20 unc
47	127783	Pulley Idler V-Belt	163	74780416	Bolt Hex Fin 1/4-20 x 1
48	154407	Bellcrank Clutch Grnd Drustl	165	165623	Bracket Pivot Lever
49	123205X	Retainer Belt	166	17490510	Screw 5/16-18 x 1.0 x .125
50	72110612	Bolt Carr. Sh. 3/8-16 x 1-1/2 Gr. 5	168	165492	Bolt Shoulder 5/16-18 x .561
51	73680600	Nut	169	165580	Plate Fastening
52	73680500	Nut Crownlock 5/16-28	197	169613	Nyliner Snap-In 5/8
53	199652	Link Clutch	198	169593	Washer Nyliner 7/8 ID x .105 HYD
55	105709X	Spring Return Clutch	199	169612	Bolt Shoulder 5/16-18 unc
56	17060620	Screw 3/8-16 x 1-1/4	200	72140508	Bolt Rdhd Sqnk 5/16-18 unc x 1
57	140294	V-Belt Drive	202	72110614	Bolt RdHd 3/8-16 unc x 1-1/2 Gr. 5
59	169691	Keeper Belt Center	205	19171616	Washer 17/32 x 1 x 16 Ga.
61	17120614	Screw 3/8-16 x .875	212	145212	Nut Hex Flange Lock
62	8883R	Cover Pedal	263	17000612	Screw 3/8-16 x .75
63	180219	Engine Pulley	268	182402	Guard Muffler
64	173937	Bolt Hex 7/16-20 x 4 x Gr. 5-1.5	275	19131614	Washer 13/32 x 1 x 14 Ga.
65	10040700	Washer			
66	154778	Keeper Belt Engine Hydro			
69	142432	Screw Hex wsh HiLo 1/4 x 1/2 unc			
70	180218	Guide Belt Mower Drive RH			

**NOTE:** All component dimensions given in U.S. inches  
1 inch = 25.4 mm.

TRACTOR - - MODEL NUMBER 917.253210

ENGINE

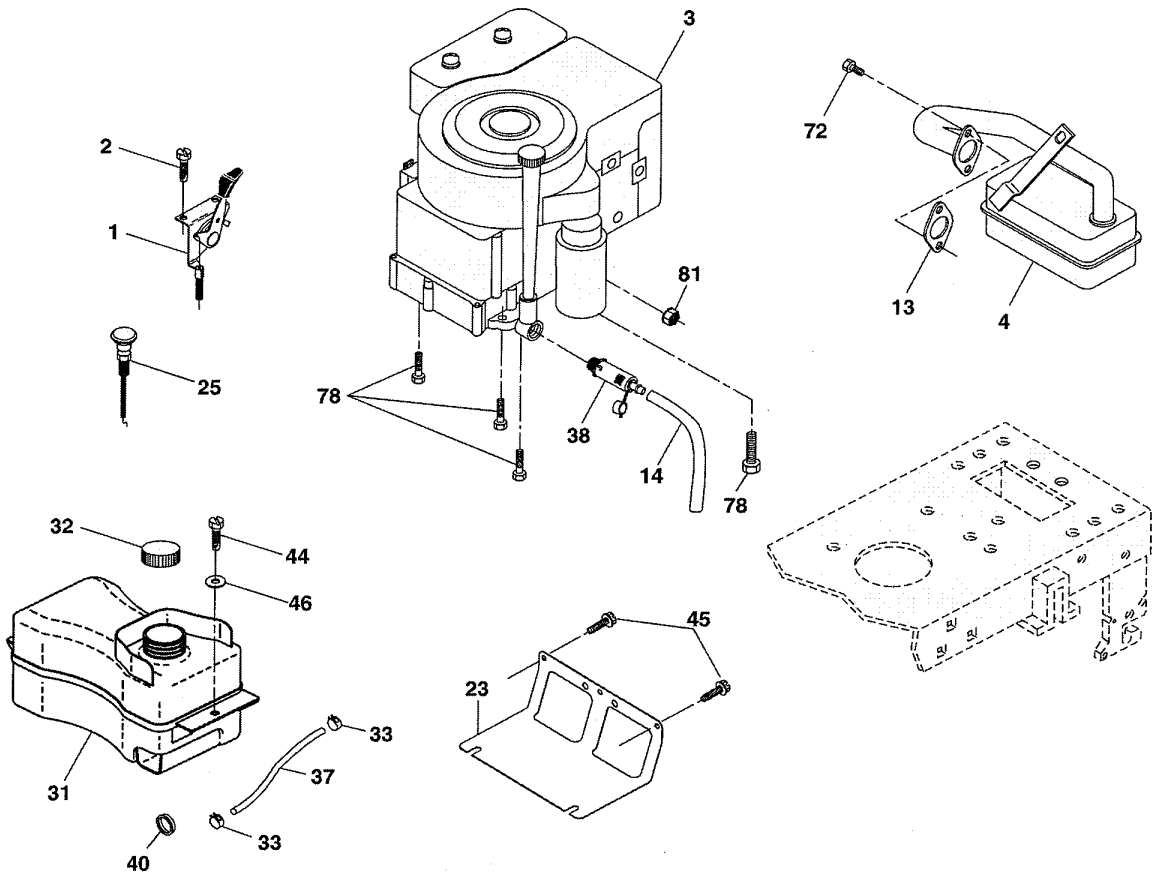

29

<b>OPTIONAL EQUIPMENT</b> <b>Spark Arrester</b>
----------------------------------------------------

engine-LT\_bs\_4

## TRACTOR - - MODEL NUMBER 917.253210

### ENGINE

KEY NO.	PART NO.	DESCRIPTION
1	170545	Control, Throttle/Choke
2	17720408	Screw, Hex Head, Thread Cutting 1/4-20 x 1/2
3	-----	Engine, Briggs Model No. 31G777-0294-B1 (See Engine Breakdown)
4	137352	Muffler
13	165291	Gasket
14	148456	Tube Drain Oil Easy
23	169837	Shield Brn/Dbr Guard
25	187770X428	Control Choke
29	137180	Arrester, Spark
31	407516	Tank, Fuel
32	197725	Cap Assembly, Fuel
33	123487X	Clamp, Hose
37	137040	Line, Fuel
38	181654	Plug, Drain Oil Easy
40	124028X	Bushing Snap
44	17670412	Screw, Hex Washer Head, Thd., Roll. 1/4-20 x 3/4
45	17000612	Screw Hex Wsh Thdr 3/8-16 x 3/4
46	19091416	Washer 9/32 x 7/8 x 16 Ga.
72	192334	Screw Socket Head Cap 5/16-18 x 3/4
78	17060620	Screw 3/8-16 x 1-1/4
81	73510400	Nut Keps Hex 1/4-20 unc

**NOTE:** All component dimensions given in U.S. inches  
1 inch = 25.4 mm

### Engine Power Rating Information

The gross power rating for individual gas engine models is labeled in accordance with SAE (Society of Automotive Engineers) code J11940 (Small Engine Power & Torque Rating Procedure), and rating performance has been obtained and corrected in accordance with SAE J1995 (Revision 2002-5). Actual gross engine power will be lower and is affected by, among other things, ambient operating conditions and engine-to-engine variability. Given both the wide array of products on which engines are placed and the variety of environmental issues applicable to operating the equipment, the gas engine will not develop the rated gross power when used in a given piece of power equipment (actual "on-site" or net horsepower). This difference is due to a variety of factors including, but not limited to, accessories (air cleaner, exhaust, charging, cooling, carburetor, fuel pump, etc.), application limitations, ambient operating conditions (temperature, humidity, altitude), and engine-to-engine variability. Due to manufacturing and capacity limitations, Briggs & Stratton may substitute an engine of higher rated power for this Series engine.

## TRACTOR -- MODEL NUMBER 917.253210

### STEERING ASSEMBLY

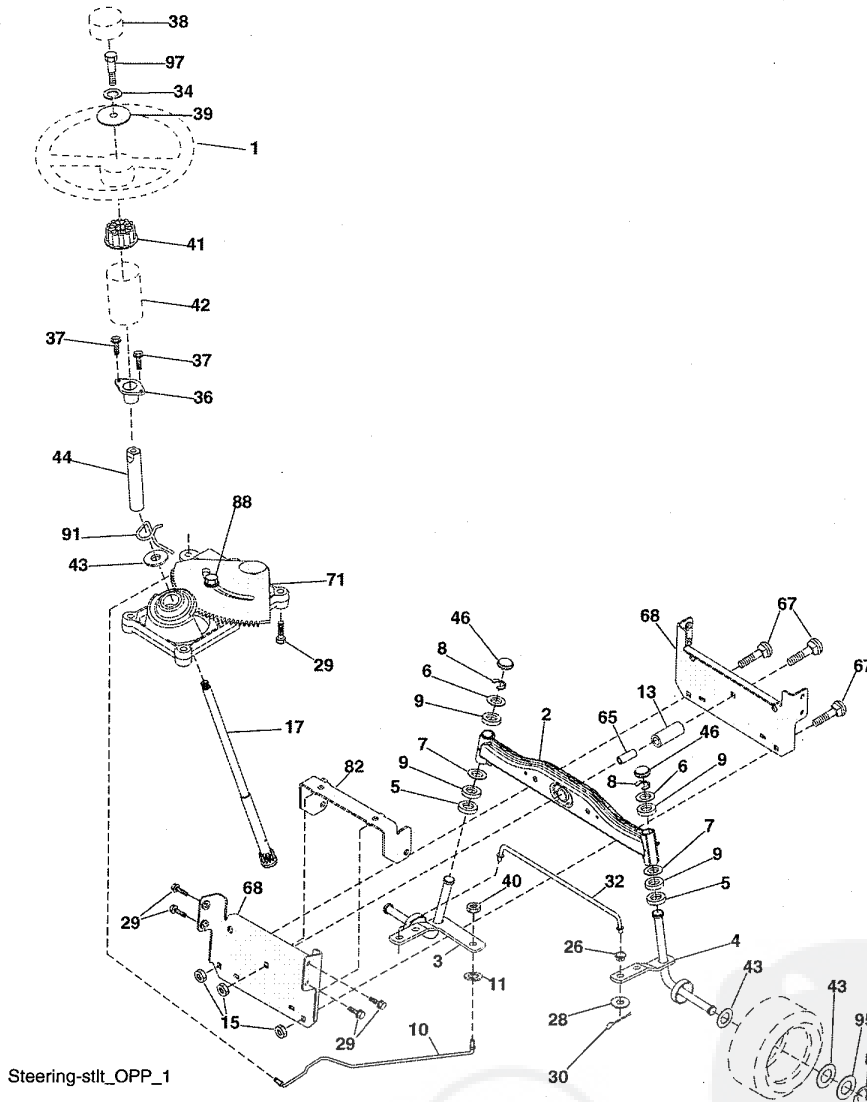

KEY NO.	PART NO.	DESCRIPTION
1	414851X428	Steering Wheel
2	195672	Axle Assembly
3	169840	Spindle Assembly, L.H.
4	169839	Spindle Assembly, R.H.
5	6266H	Bearing, Race, Thrust, Hardened
6	121748X	Washer 25/32 x 1-5/8 x 16 Ga.
7	19272016	Washer 27/32 x 1-1/4 x 16 Ga.
8	12000029	Ring, Clip
9	3366R	Bearing Col. Strg.
10	175121	Draglink
11	STD551137	Washer, Lock
13	136518	Spacer Brg Axle Front
15	145212	Nut, Hexflange Lock
17	190753	Shaft, Steering
26	126847X	Bushing, Link, Drag
28	19131416	Washer 13/32 x 7/8 x 16 Ga.
29	17000612	Screw 3/8-16 x 3/4
30	STD561210	Pin
32	192757	Rod, Tie
34	10040500	Washer Lock Hvy Hlcl Spr. 5/16
36	155099	Bushing, Steering

KEY NO.	PART NO.	DESCRIPTION
37	152927	Screw
38	414852X428	Insert, Steering Wheel
39	19113812	Washer 11/32 ID x 2-3/8 OD x 12 Ga.
40	73540600	Nut Crownlock 3/8-24
41	186737	Adaptor, Steering Wheel
42	145054x428	Boot, Steering Shaft
43	121749X	Washer 25/32 x 1-1/4 x 16 Ga.
44	190752	Extension Shaft Steering
46	121232X	Cap, Spindle
65	414736	Spacer Brace Axle
67	72110618	Bolt Rdhd Sqnk 3/8-16 x 2-1/4
68	169827	Axle, Brace
71	175146	Steering Asm
82	199978	Bracket Susp Chassis Front
88	175118	Bolt Shoulder 7/16-20
91	175553	Clip Steering
95	188967	Washer Hardened .793x1.637x.060
97	74780564	Bolt 5/16-18 unc x 4 Gr. 5

**12** NOTE: All component dimensions give in U.S. inches  
1 inch = 25.4 mm

TRACTOR -- MODEL NUMBER 917.253210

SEAT ASSEMBLY

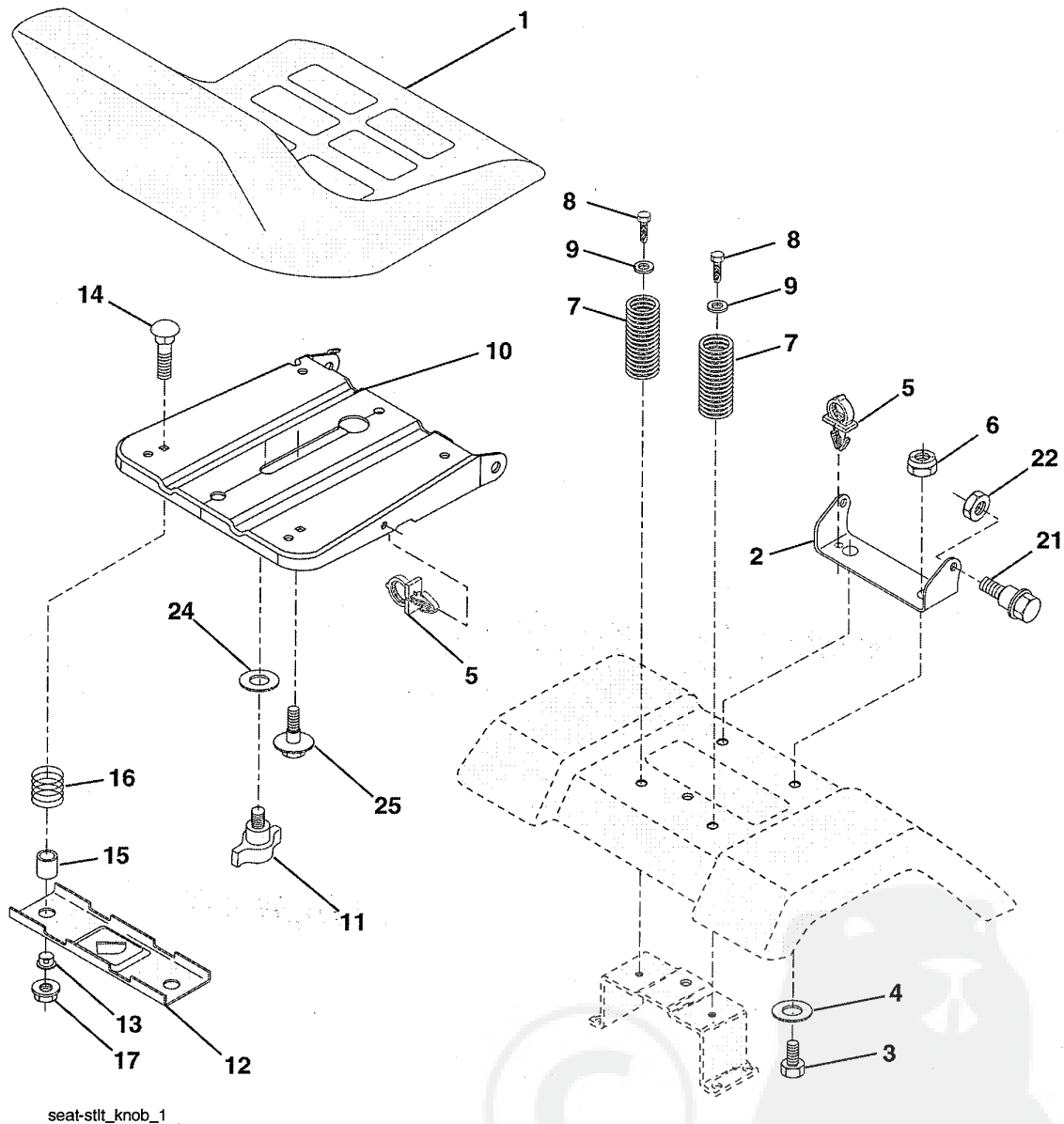

seat-stlt\_knob\_1

KEY NO.	PART NO.	DESCRIPTION
1	188939	Seat
2	140551	Bracket, Pivot, Seat
3	71110616	Bolt
4	19131610	Washer 13/32 x 1 x 10 Ga.
5	145006	Clip, Push-In Hinged
6	STD541437	Nut
7	124181X	Spring, Seat
8	17000616	Screw 3/8-16 x 1-1/2
9	19131614	Washer 13/32 x 1 x 14 Ga.
10	195530	Pan, Seat
11	166369	Knob Seat
12	174648	Bracket, Switch Mounting

KEY NO.	PART NO.	DESCRIPTION
13	121248X	Bushing, Snap
14	72050412	Bolt, Carriage 1/4-20 x 1-1/2
15	134300	Spacer, Split .28 x .88
16	121250X	Spring
17	123976X	Locknut, Flange 1/4 Gr. 5
21	171852	Bolt, Shoulder 5/16-18 unc
22	STD541431	Nut
24	19171912	Washer 17/32 x 1-3/16 x 12 Ga.
25	127018X	Bolt Shoulder 5/16-18 x .62

NOTE: All component dimensions give in U.S. inches  
1 inch = 25.4 mm

TRACTOR -- MODEL NUMBER 917.253210

MOWER DECK

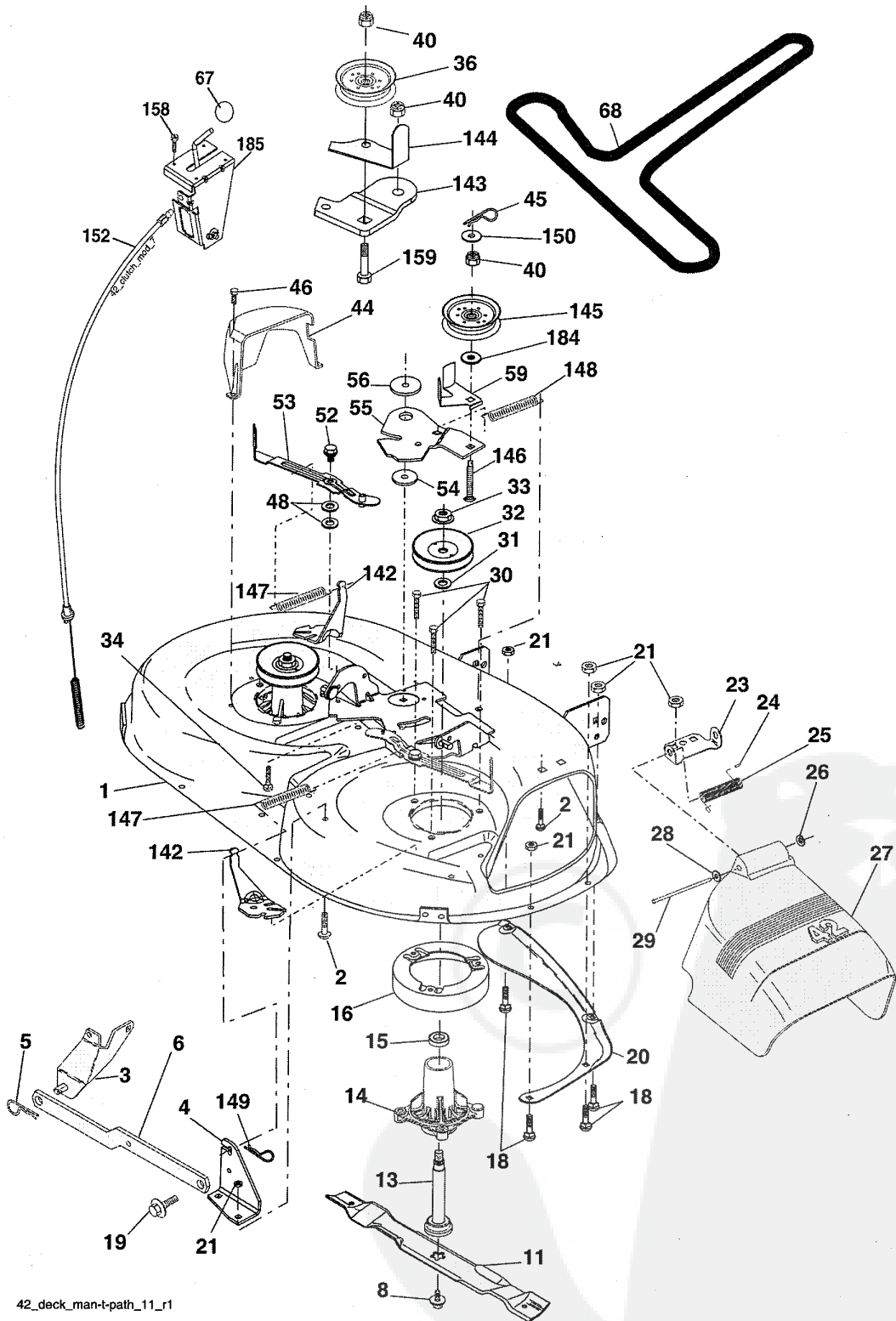

42\_deck\_man-t-path\_11\_r1

**TRACTOR - - MODEL NUMBER 917.253210**

**MOWER DECK**

<b>KEY NO.</b>	<b>PART NO.</b>	<b>DESCRIPTION</b>	<b>KEY NO.</b>	<b>PART NO.</b>	<b>DESCRIPTION</b>
1	165892	Mower Deck Assembly, 42"	48	133944	Washer, Hardened
2	STD533107	Bolt	52	139888	Bolt, Shoulder 5/16-18 unc
3	138017	Bracket Assembly, Sway Bar, Front	53	184907	Arm Assembly, Pad, Brake
4	165460	Bracket Sway Bar 38/42" eck	54	178515	Washer, Hardened
5	STD624008	Retainer Spring	55	155046	Arm, Idler
6	178024	Bar Sway Deck	56	165723	Spacer, Retainer
8	193003	Bolt, Hex 3/8-24 x 1.25 Gr. 8	59	141043	Guard, TUV Idler
11	134149	Blade, Mulching Std. (For mulching mowers only)	67	149846	Knob Custom Oval
			68	180215	V-Belt
13	192872	Shaft Assembly, Mandrel, Vented	142	195784	Arm Spring Brake Mower
14	187281	Housing, Mandrel, Vented	143	157109	Bracket Arm Idler 42"
15	110485X	Bearing, Ball, Mandrel	144	158634	Keeper Belt 42" Clutch Cable
16	174493	Stripper, Mower Deck	145	165888	Pulley Idler Flat
18	72140505	Bolt, Carriage 5/16-18 x 5/8	146	171977	Bolt Carriage Idler
19	132827	Bolt, Shoulder	147	179748	Spring Extension
20	159770	Baffle, Vortex	148	169022	Spring Return Idler
21	STD541431	Nut Crownlock 5/16-18 unc	149	165898	Retainer Spring Yellow Zinc
23	177563	Bracket, Deflector	150	19091210	Washer 9/32 x 3/4 x 10 Ga.
24	105304X	Cap, Sleeve	152	181555	Cable Clutch 42 In
25	123713X	Spring, Torsion, Deflector	158	17720408	Screw Hex Thd Cut 1/4-20 x 1/2
26	110452X	Nut, Push	159	72140614	Bolt Rdhd Sqd 3/8-16 unc x 1-3/4
27	130968X428	Shield, Deflector	184	19131410	Washer 13/32 x 7/8 x 10 Ga.
28	19111016	Washer 11/32 x 5/8 x 16 Ga.	185	188234	Head Assy. Cable Clutch
29	131491	Rod, Hinge	--	192870	Mandrel Assembly (Includes hous- ing assembly, and bearing only-pul- ley/nut/washer and blade bolt/wash- er not included)
30	173984	Screw Thdrol DOD PT Hex	--	416611	Replacement Mower, Complete
31	187690	Washer, Spacer			
32	153535	Pulley, Mandrel			
33	400234	Nut, Toplock, Flanged			
34	72110612	Bolt Carr. Sh. 3/8-16 x 1-1/2 Gr. 5			
36	131494	Pulley, Idler, Flat			
40	73900600	Nut Lock Flg. 3/8-16 unc			
44	140088	Guard, Mandrel, L.H.			
45	STD624003	Retainer			
46	137729	Screw, Thd. Roll 1/4-20 x 5/8			

**NOTE:** All component dimensions give in U.S. inches  
1 inch = 25.4 mm

## TRACTOR -- MODEL NUMBER 917.253210

### DECALS

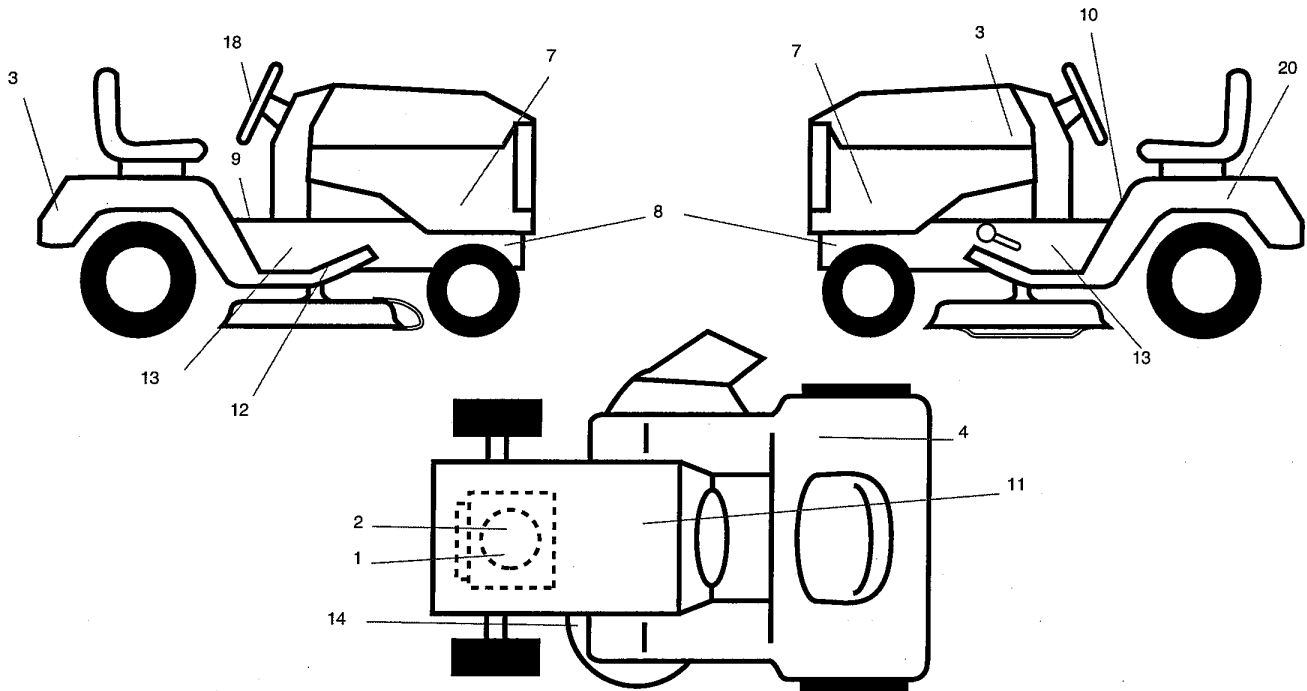

KEY NO.	PART NO.	DESCRIPTION	KEY NO.	PART NO.	DESCRIPTION
1	196841	Decal, Warning Engine Symbols	17	196357	Decal, Warning Cutfinger Symbols
2	420132	Decal, HP Engine	18	420121	Decal, Wheel Steering
3	411697	Decal, Hood	20	145005	Decal, Battery Dngr/Psn Eng
4	180432	Decal, Fender DB/CE	--	138311	Decal, Lift Handle
7	404492	Decal, Hood Side	--	162598	Decal, Load Limit
8	159736	Decal, Hot Muffler	--	166960	Decal, Bypass
9	159737	Decal, Brake/Clutch	--	179768X428	Pad, Footrest LH
10	400389	Decal, Brake parking	--	179769X428	Pad, Footrest RH
11	140837	Decal, HP Engine	--	419970	Manual, Operator's Euro
12	197490	Decal, V-Belt Drive Schematic	--	419972	Manual, Operator's Scan
13	411644	Decal, Chassis	--	419973	Manual, Operator's E-Bloc
14	160396	Decal, V-Belt Schematic	--	419974	Manual, Operator's Baltic
15	182166	Decal, Cutfinger	--	419971	Manual, Parts

### WHEELS & TIRES

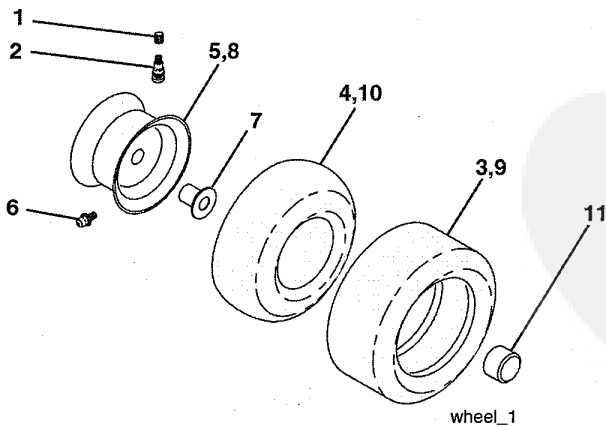

KEY NO.	PART NO.	DESCRIPTION
1	59192	Valve Cap, Tire
2	65139	Stem, Valve
3	106222X	Tire, Front
4	59904	Tube, Front Tire (Not Provided, Service Item Only)
5	106732X624	Rim, Front
6	278H	Fitting, Grease (Front Wheel Only)
7	9040H	Bearing, Flange (Front Wheel Only)
8	106108X624	Rim, Rear
9	106268X	Tire, Rear
10	7152J	Tube, Rear Tire (Not Provided, Service Item Only)
11	104757X428	Cap, Axle
--	144334	Sealant, Tire 10 oz.

**NOTE:** All component dimensions give in U.S. inches  
1 inch = 25.4 mm



TRACTOR -- MODEL NUMBER 917.253210

LIFT ASSEMBLY

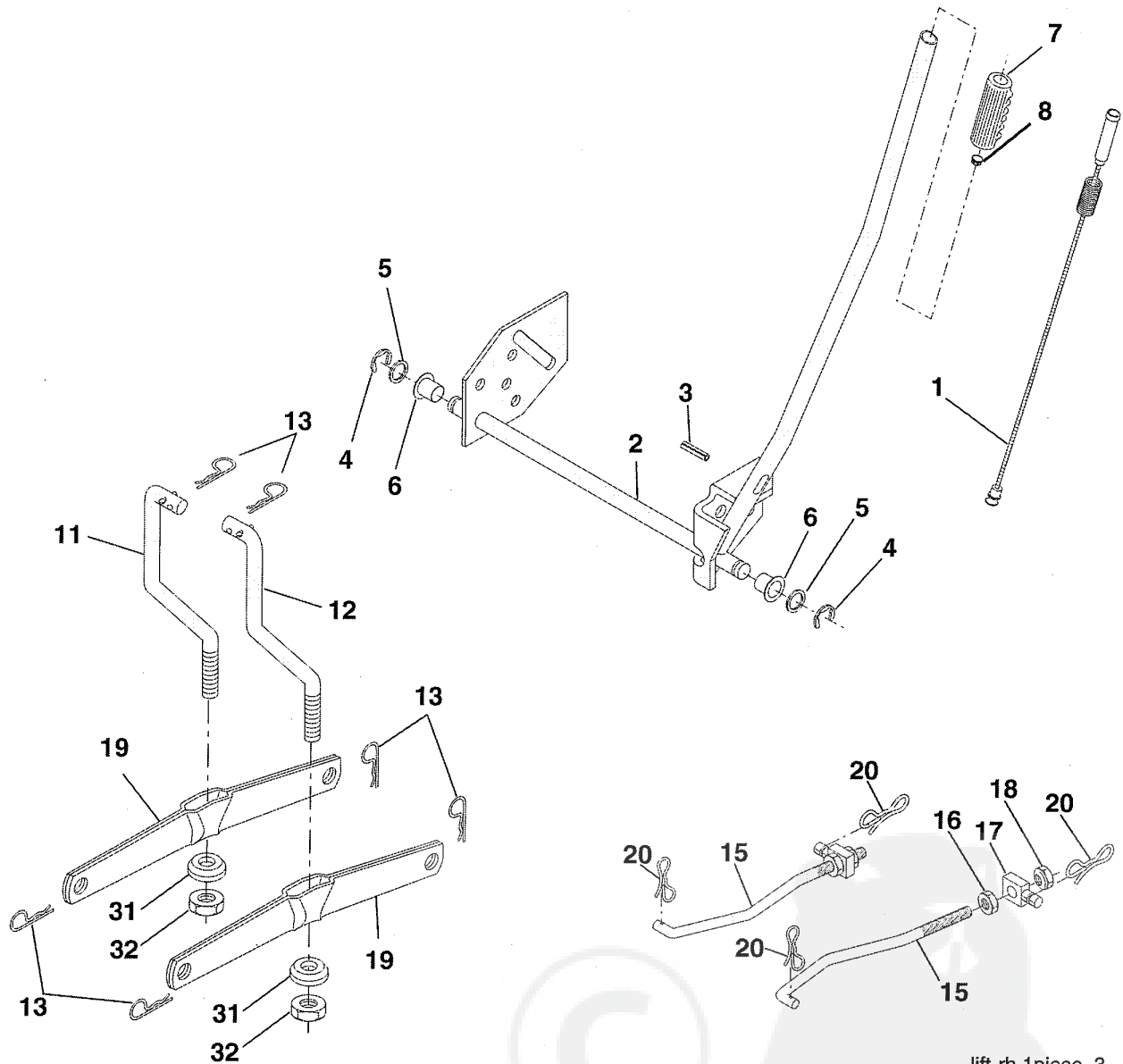

lift-rh.1piece\_3

KEY NO.	PART NO.	DESCRIPTION
1	159460	Lift Lever Inner Wire Assembly
2	159471	Shaft Assembly, Lift
3	105767X	Pin, Groove
4	12000002	E-Ring
5	19211621	Washer 21/32 x 1 x 21 Ga.
6	120183X	Bearing, Nylon
7	125631X	Grip, Handle, Fluted
8	122365X	Button, Plunger, Red
11	139865	Link, Lift, L.H.
12	139866	Link, Lift, R.H.
13	STD624008	Retainer Spring

KEY NO.	PART NO.	DESCRIPTION
15	173288	Link, Front
16	73350800	Nut, Hex, Jam 1/2-13 unc
17	175689	Trunnion
18	73800800	Locknut w/Washer Insert 1/2-13 unc
19	139868	Arm, Suspension, Rear
20	194209	Pin Cotter 7/16 Bow Tie Lock
31	169865	Bearing, Pvt, Lift
32	73540600	Nut, Crownlock 3/8-24

NOTE: All component dimensions give in U.S. inches  
1 inch = 25.4 mm

**TRACTOR - - MODEL NUMBER 917.253210**  
**HYDRO TRANSAXLE - - MODEL NUMBER 322-0510**

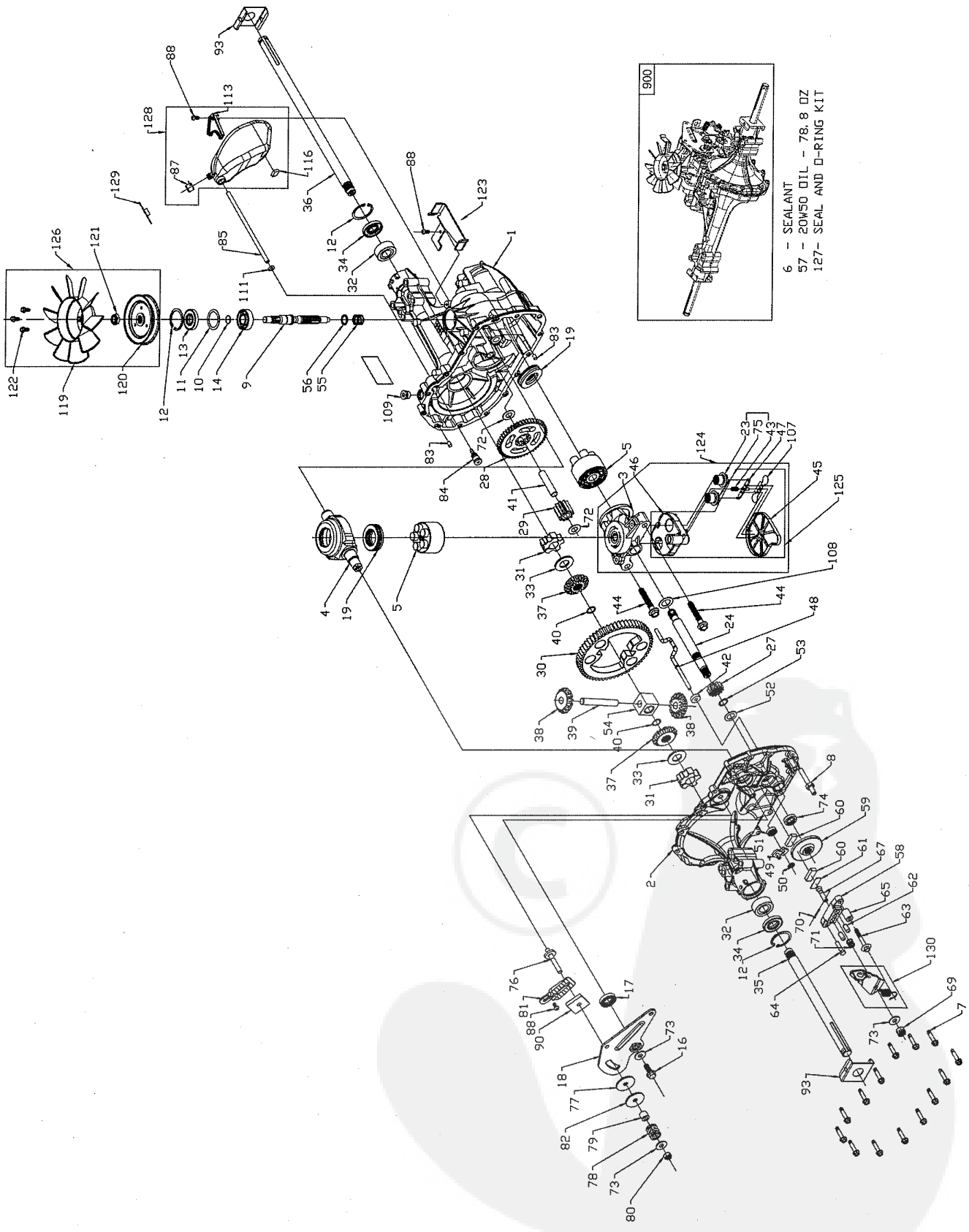

**TRACTOR - - MODEL NUMBER 917.253210**  
**HYDRO TRANSAXLE - - MODEL NUMBER 322-0510**

KEY NO.	PART NO.	DESCRIPTION	KEY NO.	PART NO.	DESCRIPTION
1	170351	Kit, Main Housing Main Housing, Machined Bushing .865 X .985 X .790	64	142892	Bolt, Nylok
2	170352	Kit, Side Housing Side Housing, Machined Bushing .865 X .985 X .790 Bushing .624 X .719 X .562	65	170411	Spacer, Brake Torsion Spring
3	170353	Kit, Center Section Center Section, Machined Bushing .707 X .788 X .591	67	170413	Bolt, Square Head - Brake
4	170354	Swashplate, Trunnion Machined	69	170415	Nut, Castle 5/16-24
5	169898	Kit, Cylinder Block (10cc) Block - Cylinder Piston Spring, Compression Washer - Thrust	70	170416	Pin, Cotter 3/32x3/4
6	178322	Sealant Tube	71	170417	Brake Spring
7	170356	Hexflange Screw 1/4-20 X 1.25	72	170418	Washer (310-0750)
8	170357	Stud, 5/16-24 Hex Double End	73	142884	Washer, Flat
9	170358	Shaft, Input	74	170419	Seal, Oil
10	170359	Retaining Ring	75	170420	Ass'y Check Plug
11	170360	Spacer	76	170421	Bolt, Stud 5/16-24
12	169870	Retaining Ring	77	170422	Puck, Friction
13	170361	Seal, Lip .67 X 1.58 X .276	78	142969	Spring
14	173158	Bearing, Ball 6203 (BDR)	79	142980	Spacer
16	170362	Hex Flange Head Screw 1/4-20 X 1.25	80	150778	Nut, Nylon Insert Hex Lock 5/16-24
17	170363	Seal, Lip 18 X 32 X 7	81	170423	Wedge, Friction
18	170364	Arm, Control	82	170424	Clip, Washer
19	173159	Bearing, Thrust (10cc)	83	161168	Pin
23	170365	Check Plug Assembly	84	170425	Fitting, 5/16 X Sae 5/32 Tube
24	170366	Shaft Motor	85	170426	Hose, Expansion Tank
27	170367	Gear, Pinion, 13t	87	173160	Cap, Vent
28	170368	10t / 48t Gear	88	178334	Bolt, Self Tapping (BDR)
29	170369	Gear, 10t Jackshaft	90	170430	Puck, Inner Wedge
30	170370	60t Bullgear	93	170431	Spring Clip, Housing
31	170371	Sleeve Bearing .75 X 1.75 X .625	107	170432	Deflector
32	170389	Sleeve Bearing (Outboard) .75 X 1.575 X .625	108	170433	Washer, Motor Shaft .71ID X .15OD X .03 Thick
33	142991	Washer	109	170434	Plug, Straight Thread 9/16-18
34	170390	Lip Seal, Axle Shaft	111	170435	O-ring .7 X .301 ID
35	170391	Shaft, Axle (Keyed, R.h.)	113	170437	Bracket, Support Expansion Tank
36	170392	Shaft, Axle (Keyed, L.h.)	119	173161	Fan (310-3000)
37	150792	Gear, Splined Diff. (210-1000 & 310-0750)	120	170440	Pulley
38	150793	Gear, Miter Diff. (210-1000 & 310-0750)	121	170441	Hex Nut Locking
39	150809	Differential Shaft (310-0750)	122	173162	Screw, #12-24 Hx Hd Self Tapping (310-3000)
40	170393	Retaining Ring	123	173163	Bracket, Belt Keeper
41	170394	Pin, Jackshaft	124	170444	Kit, Center Section Filter Bypass Center Section Machining Base Filter w/ Poppet Check Plug Assembly, 027 Washer Check Plug Assembly, Washer Spring, Bypass Actuator, Bypass Deflector Bottom, Filter Bushing .707 X .788 X .591
42	170395	Magnet, Ring	125	170445	Kit, Filter Bottom, Filter Spring, Bypass Actuator, Bypass Deflector Base, Filter W/ Poppet
43	170396	Spring, Bypass	126	173164	Kit, Fan / Pulley #12 T.f. Screw - Indented Hex Washer Head Fan Pulley 4.315 X .801
44	150797	Bolt 3/8-24 X 2-1/2	127	170447	Kit, Seal Lip Seal .67 X 1.58 X .276 Lip Seal 18 X 32 X 7 Lip Seal .706 X 1.584 X .25 Lip Seal .741 X .250 X .250 TC Oil Seal 625 X 1.0 X .25 O-ring .07 X .301 ID
45	170397	Filter	128	173165	Kit, Expansion Tank Tank, Expansion Cap, Vent Bolt, Self Tapping 10-32 X 1/2 Bracket, Support Expansion Tank Silicon Sponge 1/2 X 1/2 X 3/16
46	170398	Base, Filter	129	191032	Cap, Expansion Tank Shipping
47	170399	Actuator, Bypass	130	186352	Kit, Brake Arm And Spring Arm, Brake Spring, Brake Arm Bias Instruction Sheet
48	170400	Rod, Bypass Actuator	900	171613	Transaxle
49	170401	Arm, Bypass			
50	170402	Retaining Ring .25 External			
51	170403	Seal, Lip .741 X .25 X .25			
52	170404	Washer, Flat 0.050" (210-1000)			
53	170405	Retaining Ring			
54	170406	Bearing, Center Block			
55	142977	Spring, Helical Compression			
56	142978	Washer, Block Thrust			
57	---	20w-50 Oil 78.8 Oz			
58	142929	Kit, Brake Yoke			
59	170408	Rotor, Brake			
60	142883	Brake Puck			
61	142882	Brake Puck Plate			
62	170409	Pin, Brake Actuating			
63	170410	HFHCS 1/4-20 X 2 W/patch, Special Flange			

**NOTE:** All component dimensions give in U.S.  
1 inch = 25.4 mm

**TRACTOR - - MODEL NUMBER 917.253210**  
**BRIGGS & STRATTON ENGINE-MODEL NUMBER 31G777, TYPE NUMBER 0294-B1**

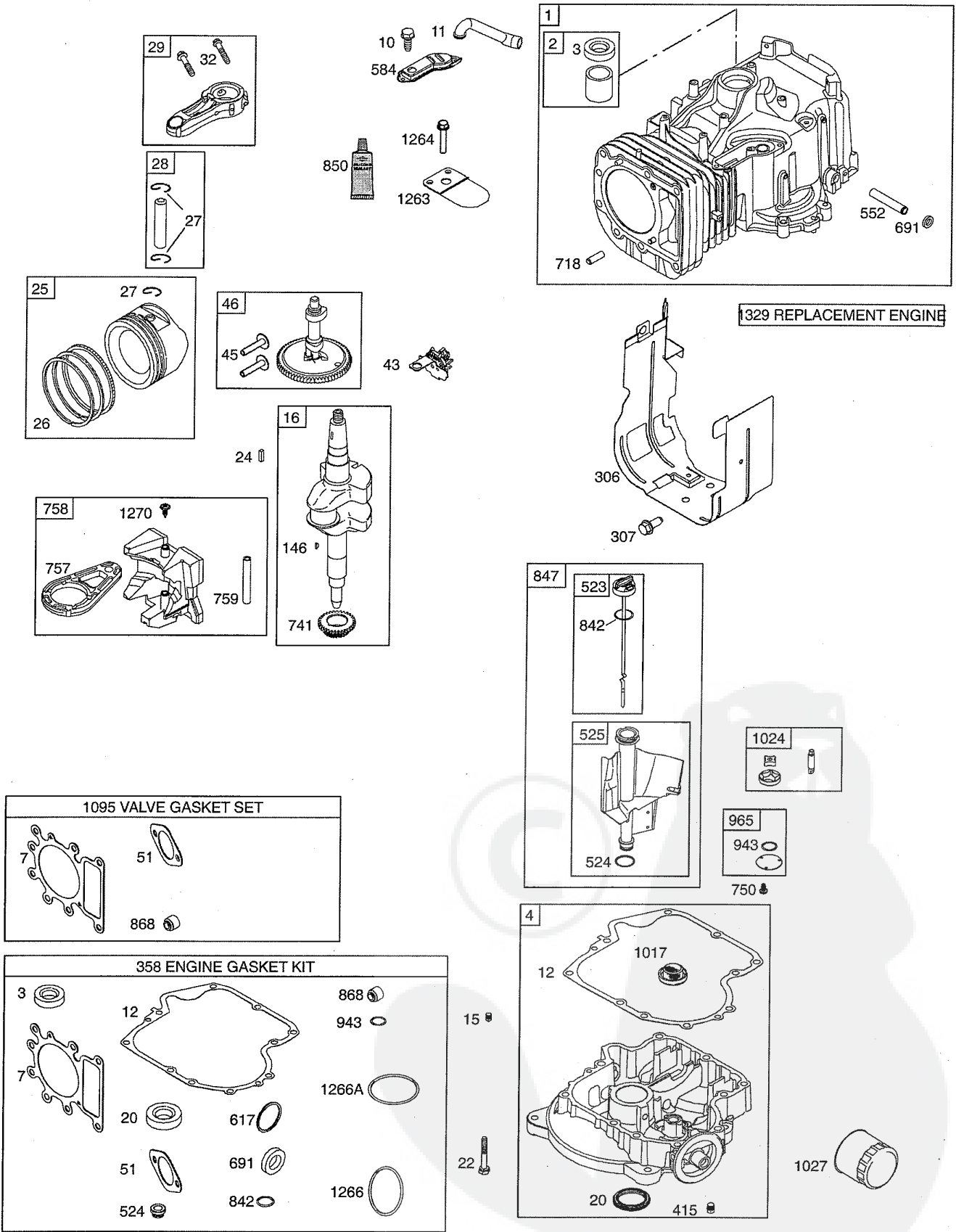

**TRACTOR - - MODEL NUMBER 917.253210**  
**BRIGGS & STRATTON ENGINE-MODEL NUMBER 31G777, TYPE NUMBER 0294-B1**

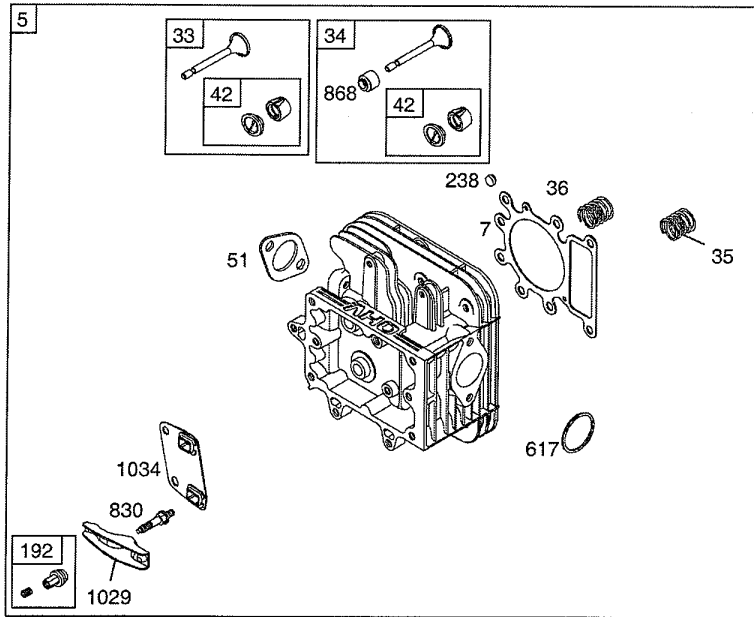

1036 EMISSIONS LABEL

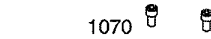
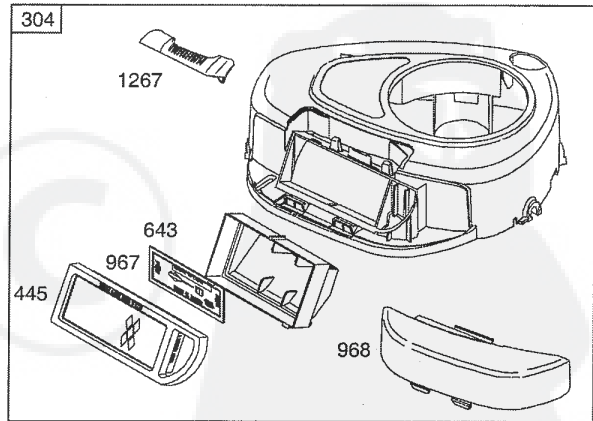
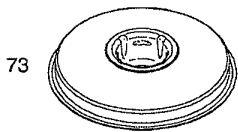
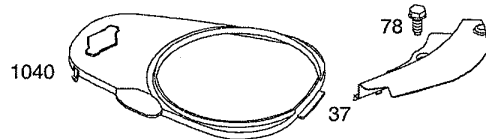
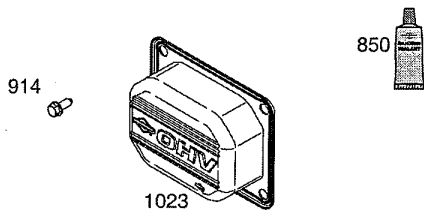

1330 REPAIR MANUAL

48 SHORT BLOCK

1329 REPLACEMENT ENGINE

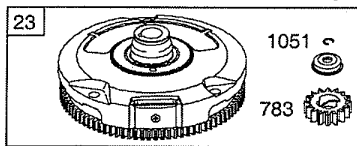

**TRACTOR - - MODEL NUMBER 917.253210  
BRIGGS & STRATTON ENGINE-MODEL NUMBER 31G777, TYPE NUMBER 0294-B1**

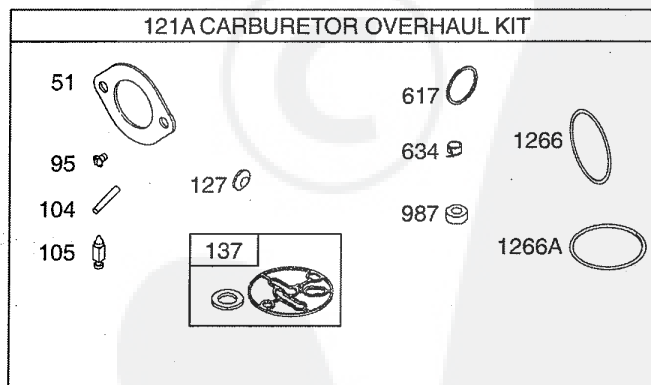
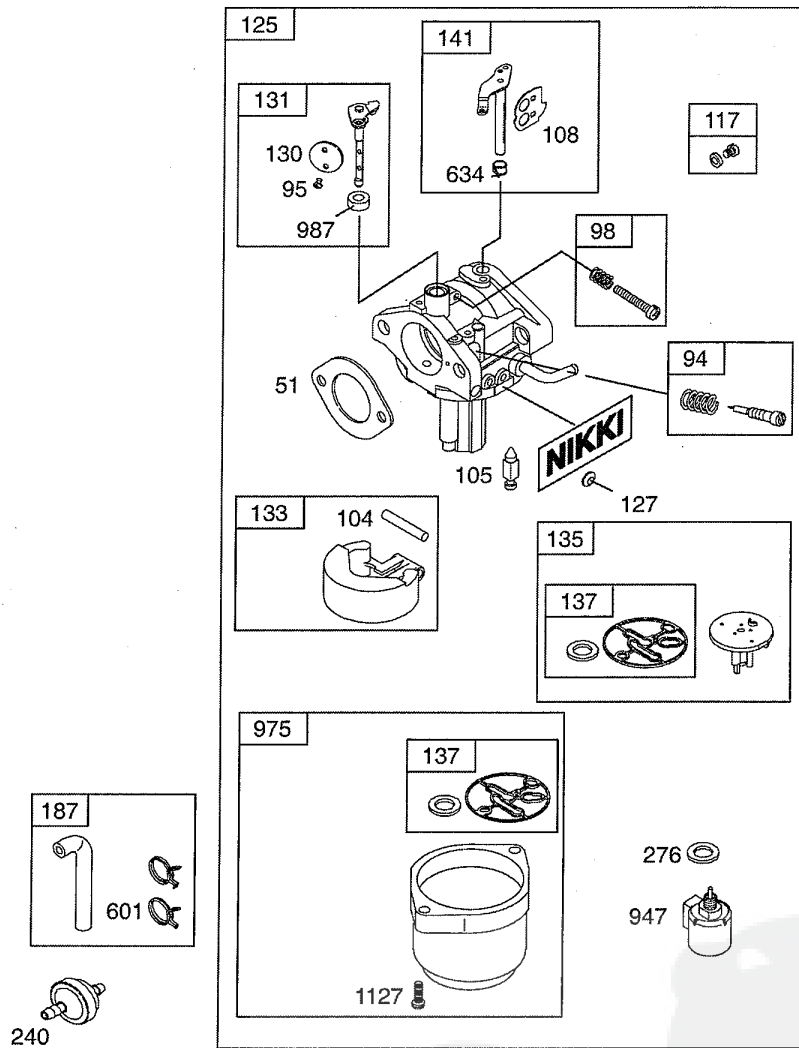

**TRACTOR - - MODEL NUMBER 917.253210  
BRIGGS & STRATTON ENGINE-MODEL NUMBER 31G777, TYPE NUMBER 0294-B1**

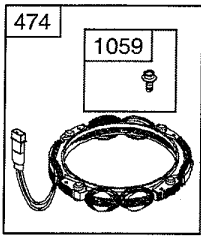

1119

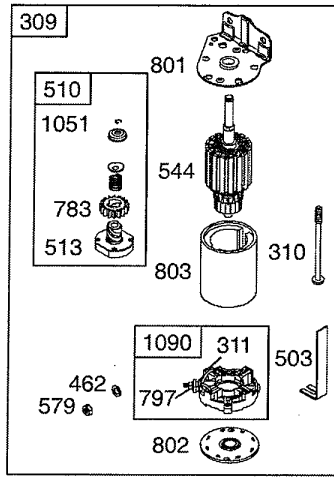
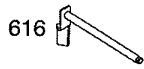
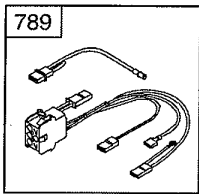

729  
697

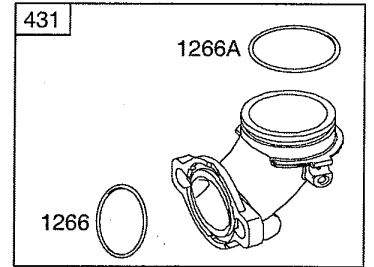

404 @  
614 R

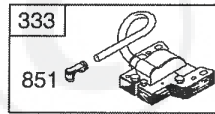
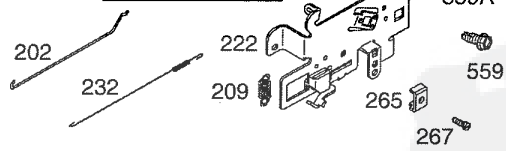
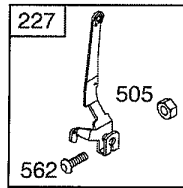

**TRACTOR - - MODEL NUMBER 917.253210**  
**BRIGGS & STRATTON ENGINE-MODEL NUMBER 31G777, TYPE NUMBER 0294-B1**

KEY NO.	PART NO.	DESCRIPTION	KEY NO.	PART NO.	DESCRIPTION
1	793987	Cylinder Assembly	265	691024	Clamp-Casing
2	399265	Kit-Bushing/Seal (Magneto Side)	267	794904	Screw (Casing Clamp)
3	391086	• Seal-Oil (Magneto Side)	276	695410	Sealing-Washer (Nikki)
4	697188	Sump-Engine	304	698599	Housing-Blower
5	793989	Head-Cylinder	305	697102	Screw (Blower Housing)
7	794114	•+ Gasket-Cylinder Head	305A	793376	Screw (Blower Housing)
10	697157	Screw (Breather Assembly)	306	697107	Shield-Cylinder
11	794683	Tube-Breather	307	691003	Screw (Cylinder Shield)
12	697110	• Gasket-Crankcase	309	693551	Motor-Starter
13	793988	Screw (Cylinder Head)	310	690323	Screw (Starter Motor)
15	690946	Plug-Oil Drain	311	497608	Brush Set
16	697127	Crankshaft	333	795315	Armature-Magneto
20	795387	• Seal-Oil (PTO Side)	334	691061	Screw (Armature Magneto)
22	692125	Screw (Crankcase Cover)	337	691043	Spark Plug
23	693557	Flywheel	358	794150	Gasket Set-Engine
24	222698s	Key-Flywheel	363	19203	Flywheel Puller
25	792507	Piston Assembly (Standard)	383	89838	Wrench-Spark Plug
	792648	Piston Assembly (.020" Oversize)	404	691691	Washer (Governor Crank)
26	791936	Ring Set-Piston (Standard)	415	690283	Plug
	792649	Ring Set-Piston (.020" Oversize)	415A	794129	Plug
27	698469	Lock-Piston Pin	431	697122	Elbow-Intake
28	697099	Pin-Piston (Standard)	445	698083	Filter-Air Cleaner Cartridge
29	794122	Rod-Connecting (Standard)	462	691261	Washer (Brush Retainer)
32	791118	Screw (Connecting Rod)	474	696459	Alternator
33	791934	Valve-Exhaust	503	691532	Strap-Starter
34	791935	Valve-Intake	505	691251	Nut (Governor Control Lever)
35	691279	Spring-Valve (Intake)	510	693699	Drive-Starter
36	691279	Spring-Valve (Exhaust)	513	692024	Clutch-Drive
37	697352	Guard-Flywheel	523	699908	Dipstick
42	499586	Keeper-Valve	524	691032	• Seal-Dipstick Tube
43	691968	Slinger-Governor/Oil	525	697184	Tube-Dipstick
45	690564	Tappet-Valve	544		Armature-Starter (For service order 693551, Starter Motor)
46	793880	Camshaft			Bushing-Governor Lever
48	697762	Short Block	552	697144	Bolt (Governor Control Lever)
50	690193	Manifold-Intake	562	691119	Screw (Remote Choke Stop)
51	692137	• Ø+ Gasket-Intake	559	697561	Screw (Remote Choke Stop)
53	690227	Stud (Carburetor)	559A	693675	Nut (Starter Cable)
54	691148	Screw (Intake Manifold)	579	691029	Cover-Breather Passage
73	794437	Screen-Rotating	584	794682	Clamp-Hose
78	691003	Screw (Flywheel Guard)	601	791850	Pin-Cotter
94	793610	Kit-Idle Mixture (Nikki)	614	691620	Crank-Governor
95	690718	Ø Screw (Throttle Valve) (Nikki)	616	692012	• Ø O Ring Seal (Intake Manifold)
98	695408	Kit-Idle Speed (Nikki)	617	692138	Ø Spring/Seal Assembly (Nikki)
104	694918	Ø Pin-Float Hinge (Nikki)	634	698779	Boot-Spark Plug
105	696136	Ø Valve-Float Needle (Nikki)	635	691909	Retainer-Air Filter
108	695419	Valve-Choke	643	698401	Nut (Carburetor)
117	699732	Jet-Main (Standard) (Nikki)	654	690958	• Seal-Governor Shaft
121	699521	Kit-Carburetor Overhaul (Nikki)	691	692407	Screw (Drive Cap)
125	792358	Carburetor	697	690372	Pin-Locating
127	690727	Ø Plug-Welch (Nikki)	718	690959	Clip-Wire
130	699500	Valve-Throttle (Nikki)	729	691224	Gear-Timing
131	699501	Kit-Throttle Shaft (Nikki)	741	697128	Screw (Oil Pump Cover)
133	694914	Float-Carburetor (Nikki)	750	790832	Link-Counterweight
135	698780	Tube-Fuel Transfer	757	793242	Counterweight
137	698781	Ø Gasket-Float Bowl (Nikki)	758	697134	Pin-Counterweight
141	698778	Kit-Choke Shaft (Nikki)	759	697392	Gear-Pinion
146	691639	Key-Timing	783	693713	Harness-Wiring
187	791805	Line-Fuel (Cut to Required Length)	789	698329	Nut (Brush Retainer)
188	691693	Screw (Control Bracket)	797	693167	Cap-Drive
192	691986	Adjuster-Rocker Arm	801	691283	Cap-End
202	691841	Link-Mechanical Governor	802	691286	Housing-Starter (for service order 693551, Starter Motor)
209	692208	Spring-Governor	803		Stud (Rocker Arm)
222	694042	Bracket-Control			• Seal-O Ring (Dipstick Tube)
227	691374	Control Lever-Governor	830	691095	Dipstick/Tube Assembly
232	691842	Spring-Governor Link	842	691031	Sealant-Liquid
238	691843	Cap-Valve	847	790442	
240	394358s	Filter-Fuel	850	100106	



**TRACTOR - - MODEL NUMBER 917.253210**  
**BRIGGS & STRATTON ENGINE-MODEL NUMBER 31G777, TYPE NUMBER 0294-B1**

<b>KEY NO.</b>	<b>PART NO.</b>	<b>DESCRIPTION</b>
851	692424	Terminal-Spark Plug
868	690968	•+ Seal-Valve
914	691108	Screw (Rocker Cover)
943	690589	• Seal-O Ring (Oil Pump Cover)
947	695423	Solenoid-Fuel (Nikki)
950	691657	Screw (Float Bowl)
965	499613	Cover-Oil Pump
967	697015	Filter-Pre Cleaner
968	698403	Cover-Air Cleaner
975	699502	Bowl-Float (Nikki)
987	698777	∅ Seal-Throttle Shaft (Nikki)
1005	794438	Fan-Flywheel
1017	690770	Screen-Oil Pump
1023	791079	Cover-Rocker
1024	794644	Pump-Oil
1026	692003	Rod-Push (Intake)
	692011	Rod-Push (Exhaust)
1027	492932s	Filter-Oil
1029	691751	Arm-Rocker
1034	690822	Guide-Push Rod
1036		Label-Emissions (Available from an Authorized Briggs & Stratton Dealer)
1040	699852	Plate-Trim
1044	698139	Screw (Flywheel)
1051	691265	Retaining-Ring
1059	698516	Kit-Screw/Washer
1070	690363	Screw (Flywheel Fan)
1090	691293	Retainer-Brush
1091	691333	Cap-Limiter
1095	794152	Gasket Set-Valve
1119	691183	Screw (Alternator)
1127	695407	Screw (Float Bowl)
1263	697124	Reed-Breather
1264	697104	Screw (Breather Reed)
1266	691917	•∅ O Ring Seal (Intake Elbow)
1266A	697123	•∅ O Ring Seal (Intake Elbow)
1267	697419	Latch-Blower Housing
1270	793243	Plug-AVS Counterweight
1329	31G7770036	Replacement Engine (Remove 691840. If the original engine is equipped with a six pin wiring harness transfer to the replacement engine. Transfer Flywheel and Alternator Assembly from original to replacement engine. Transfer Muffler and/or spark arrester assembly from the original engine if suitable for additional service or add new parts as required.)
1330	272147	Repair Manual

- Included in Engine Gasket Set, Key. No. 358
- ∅ Included in Carburetor Overhaul Kit, Key. No. 121
- + Included in Valve Gasket Set, Key. No. 1095

**NOTE:** All component dimensions give in U.S.  
 1 inch = 25.4 mm

#### **LIMITED WARRANTY ON CRAFTSMAN RIDING EQUIPMENT**

For two (2) years from the date of purchase, if this Craftsman Riding Equipment is maintained, lubricated and tuned up according to the instructions in the owner's manual, Sears will repair or replace free of charge any parts that are found to be defective in material or workmanship according to the guidelines of coverage listed below. Sears will also provide free labor for these applicable warranted parts for the two full years. During the first 30 days of purchase, there will be no charges to service the product at your home for issues covered by this warranty. (See exclusions below). For your convenience, IN HOME warranty service will still be available after the first 30 days of purchase, but a trip charge will apply. This charge will be waived if the Craftsman product is dropped off at an authorized Sears location. For the nearest authorized Sears location, please call 1-800-4-MY-HOME®. This warranty applies only while this product is within the United States.

This Warranty does not cover:

- Expendable items which become worn during normal use, including but not limited to blades, spark plugs, air cleaners, belts, and oil filters.
- Standard Maintenance Servicing, oil changes, or tune-ups
- Tire replacement or repair caused by punctures from outside objects, such as nails, thorns, stumps, or glass.
- Repairs necessary because of operator abuse, including but not limited to, damage caused by towing objects beyond the capability of the riding equipment, impacting objects that bend the frame or crankshaft, or over-speeding the engine.
- Repairs necessary because of operator negligence, including but not limited to, electrical and mechanical damage caused by improper storage, failure to use the proper grade and amount of engine oil, failure to keep the deck clear of flammable debris, or failure to maintain the equipment according to the instructions contained in the owner's manual.
- Engine (fuel system) cleaning or repairs caused by fuel determined to be contaminated or oxidized (stale). In general, fuel should be used within 30 days of its purchase date.
- Normal deterioration and wear of the exterior finishes, or product label replacement.
- Riding equipment used for commercial or rental purposes.

#### **LIMITED WARRANTY ON BATTERY**

For ninety (90) days from date of purchase, if any battery included with this riding equipment proves defective in material or workmanship and our testing determines the battery will not hold a charge, Sears will replace the battery at no charge. During the first 30 days of purchase, there will be no charges to replace the battery at your HOME. After the first 30 days, for your convenience, IN-HOME warranty service will still be available but a trip charge will apply. This charge will be waived if the Craftsman product is dropped off at an authorized Sears location. For the nearest authorized Sears location, please call 1-800-4-MY-HOME®.

This battery warranty applies only while this product is within the United States.

This warranty gives you specific legal rights, and you may also have other rights, which vary, from state to state.

Sears, Roebuck and Co., Hoffman Estates, IL 60179



**CRAFTSMAN®**