

GS-HLS8000V

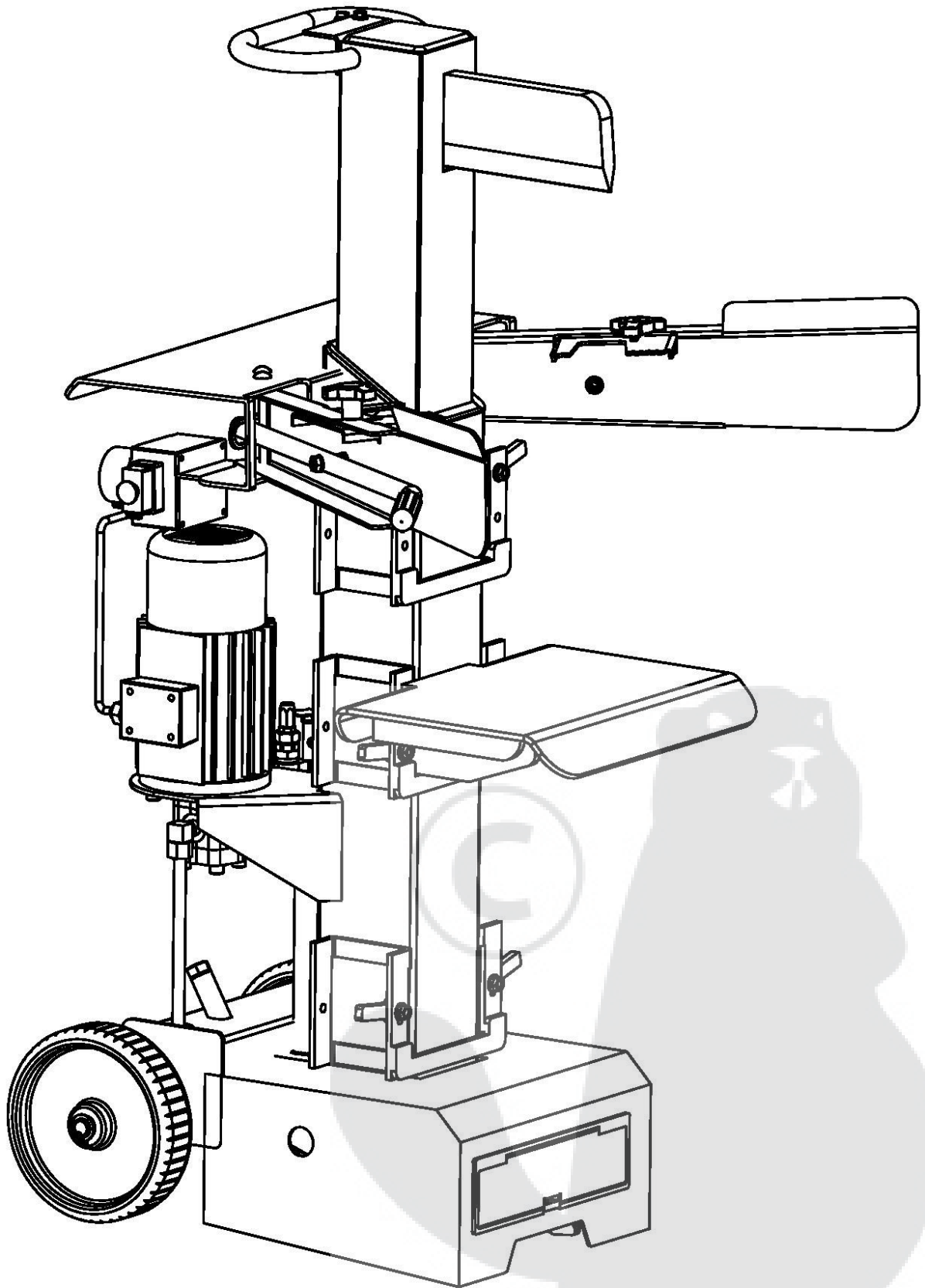

GS-HLS8000V

| Part number | Part description | Qty |
|--------------------|-------------------------------------|------------|
| GS-HLS8000V-1 | Main body column | 1 |
| GS-HLS8000V-2 | Motor | 1 |
| GS-HLS8000V-3 | direction exchanging valve assembly | 1 |
| GS-HLS8000V-4 | Oil drain pipe | 1 |
| GS-HLS8000V-5 | small lock plate | 1 |
| GS-HLS8000V-6 | M8X25 inner hex bolt | 6 |
| GS-HLS8000V-7 | M8 anti-retracting nut | 9 |
| GS-HLS8000V-8 | Flat washer M8 | 15 |
| GS-HLS8000V-9 | Main working table assembly | 1 |
| GS-HLS8000V-10 | right side clamp | 1 |
| GS-HLS8000V-11 | Operation handle sleeve | 2 |
| GS-HLS8000V-12 | Operation handle | 2 |
| GS-HLS8000V-13 | right handle side guard | 1 |
| GS-HLS8000V-14 | M8×80 bolt | 2 |
| GS-HLS8000V-15 | M8 screw knob | 2 |
| GS-HLS8000V-16 | M8×16 bolt | 2 |
| GS-HLS8000V-17 | Left handle side guard | 1 |
| GS-HLS8000V-18 | M6×12 inner hex bolt | 4 |
| GS-HLS8000V-19 | M6 nut | 4 |
| GS-HLS8000V-20 | M8 flat washer | 4 |
| GS-HLS8000V-21 | Protective guard plate | 2 |
| GS-HLS8000V-22 | left side clamp | 1 |
| GS-HLS8000V-23 | Supporting plate assembly | 1 |
| GS-HLS8000V-24 | M8X110 bolt | 4 |
| GS-HLS8000V-25 | Switch | 1 |
| GS-HLS8000V-26 | M18x65 bolg | 1 |
| GS-HLS8000V-27 | M18 anti-retracting nut | 1 |
| GS-HLS8000V-28 | fixing bush | 1 |
| GS-HLS8000V-29 | dustproof cover | 1 |
| GS-HLS8000V-30 | Fixing plate | 1 |
| GS-HLS8000V-31 | M8x15 inner hex screw | 2 |
| GS-HLS8000V-32 | M6 screw knob | 1 |
| GS-HLS8000V-33 | operation lever | 1 |
| GS-HLS8000V-34 | ram stroke control lever | 1 |
| GS-HLS8000V-35 | M8x15 inner hex screw | 1 |
| GS-HLS8000V-36 | connecting pipe | 1 |
| GS-HLS8000V-37 | piston rod assembly | 1 |
| GS-HLS8000V-38 | splitter column assembly | 1 |
| GS-HLS8000V-39 | fixing side board | 4 |
| GS-HLS8000V-40 | connecting pipe | 1 |
| GS-HLS8000V-41 | oil suction pipe | 1 |
| GS-HLS8000V-42 | connecting pipe | 1 |
| GS-HLS8000V-43 | Pump assembly | 1 |

| | | |
|----------------|----------------------|---|
| GS-HLS8000V-44 | M8x80 inner hex bolt | 4 |
| GS-HLS8000V-45 | Spring | 1 |
| GS-HLS8000V-46 | Pedal | 1 |
| GS-HLS8000V-47 | Wheel axle | 1 |
| GS-HLS8000V-48 | Wheel | 2 |
| GS-HLS8000V-49 | Pin | 2 |
| GS-HLS8000V-50 | Circuit ring | 2 |
| GS-HLS8000V-51 | Shaft | 1 |

