

PH08-SS

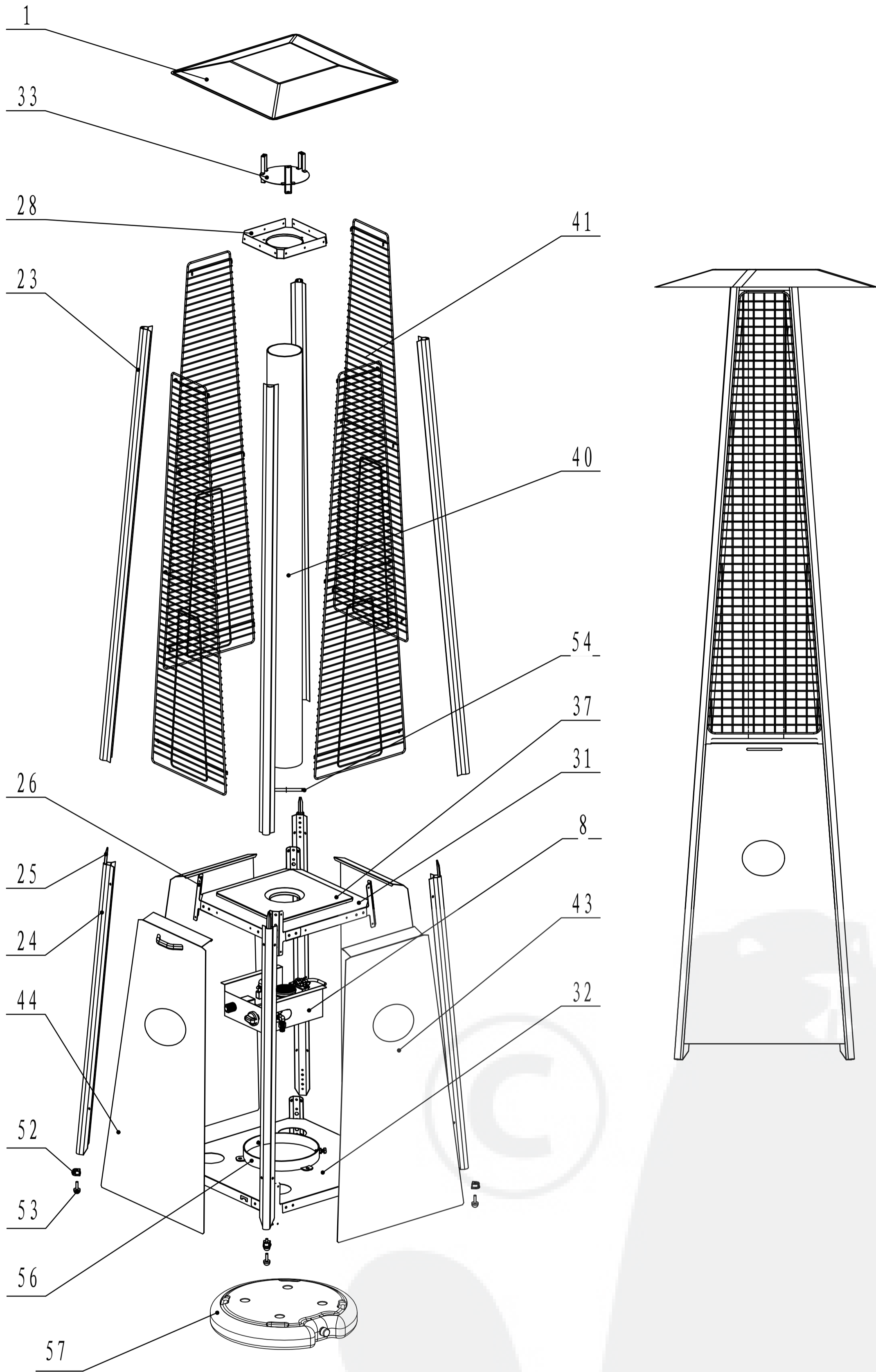

					材料:			常州市威尔莱炉业有限公司	
								户外取暖器	
标记	处数	分区	更改文件号	签名	年、月、日	阶段标记	重量	比例	
设计	费小波	2008.10.10.	标准化					1:12	
审核									
工艺			批准			共	张	第	张
								PH08/00	

Réf. N°	Part n°	Description	Qty
1	GN-PH08-SS-1	Reflector	1
8	GN-PH08-SS-8	Control Box	1
23	GN-PH08-SS-23	Upper support	4
24	GN-PH08-SS-24	Lower Support	4
25	GN-PH08-SS-25	Support	4
26	GN-PH08-SS-26	Middle Plate	1
28	GN-PH08-SS-28	Upper Plate	1
31	GN-PH08-SS-31	Plate cover	1
32	GN-PH08-SS-32	Bottom Plate	1
33	GN-PH08-SS-33	Damper	1
37	GN-PH08-SS-37	Plate cover	1
40	GN-PH08-SS-40	Glass tube	1
41	GN-PH08-SS-41	Lower protection guard	4
43	GN-PH08-SS-42	Side panel	3
44	GN-PH08-SS-44	Front panel	1
52	GN-PH08-SS-52	Nut	4
53	GN-PH08-SS-53	Screw	4
54	GN-PH08-SS-54		1
56	GN-PH08-SS-56		1
57	GN-PH08-SS-57	Weight	1

