

YINENG EAGLE

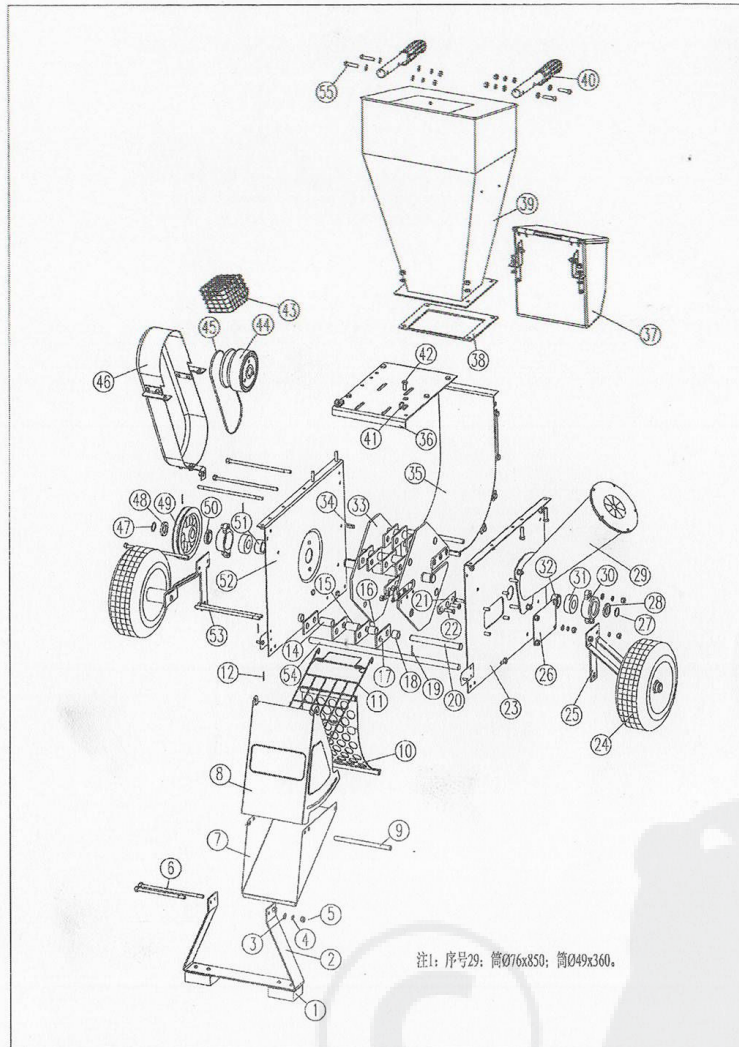

6.5 马力碎枝机零配件清单

2008 年 8 月 8 号

GN-FYS-76-1	RUBBER FOOT
GN-FYS-76-2	LEG
GN-FYS-76-3	FLAT WASHER
GN-FYS-76-4	HEX NUT
GN-FYS-76-5	LOCK WASHER
GN-FYS-76-6	HEX BOLT
GN-FYS-76-7	DISCHARGE CHUTE
GN-FYS-76-8	MOVABLE DOOR
GN-FYS-76-9	TUBE
GN-FYS-76-10	SCREEN
GN-FYS-76-11	SIDE DOOR PLATE
GN-FYS-76-12	HITCH PIN
GN-FYS-76-13	DOOR AXLE
GN-FYS-76-14	SPACER I
GN-FYS-76-15	SPACER II
GN-FYS-76-16	SPACER III
GN-FYS-76-17	HAMMER
GN-FYS-76-18	SPACER VI
GN-FYS-76-19	ROLL PIN
GN-FYS-76-20	HAMMER AXLE
GN-FYS-76-21	BLADE
GN-FYS-76-22	FLAT HD SCR
GN-FYS-76-23	BOX FRAME SIDE LEFT
GN-FYS-76-24	WHEEL
GN-FYS-76-25	WHEEL SUPPORT
GN-FYS-76-26	BLADE COVER PLATE
GN-FYS-76-27	WIRE CIRCLIP 1
GN-FYS-76-28	WASHER (RIGHT)
GN-FYS-76-29	CHIPPING CHUTE
GN-FYS-76-30	BEARING SEAT
GN-FYS-76-31	BALL BEARING
GN-FYS-76-32	SPACER (RIGHT)
GN-FYS-76-33	IMPELLER
GN-FYS-76-34	KEY
GN-FYS-76-35	REAR BOARD
GN-FYS-76-36	ENGINE SEAT
GN-FYS-76-37	TOOL BOX
GN-FYS-76-38	RUBBER GASKET
GN-FYS-76-39	HOPPER
GN-FYS-76-40	HANDLES
GN-FYS-76-41	HOOK
GN-FYS-76-42	HEX BOLT
GN-FYS-76-43	BURN-PROOF NET
GN-FYS-76-44	CLUTCH
GN-FYS-76-45	V-BELT
GN-FYS-76-46	PULLEY COVER
GN-FYS-76-47	BELT COVER BRACKET
GN-FYS-76-48	SPACER
GN-FYS-76-49	PULLEY
GN-FYS-76-50	SPECIAL WASHER (LEFT)
GN-FYS-76-51	WASHER (RIGHT)
GN-FYS-76-52	BOX FRAME SIDE
GN-FYS-76-53	WHEEL TUBE
GN-FYS-76-54	WHEEL AXLE
GN-FYS-76-55	FRONT HANDLE
GN-FYS-76-SC	SCREW WHEEL



Fig.1 Cylinder head

Réf. N°	Part n°	Description	Qty.
1	GN-FYS76-M1-1	HEAD COMP. , CYLINDRE	1
2	GN-FYS76-M1-2	GUIDE, IN. VALVE	1
3	GN-FYS76-M1-3	GUIDE, EX. VALVE	1
4	GN-FYS76-M1-4	CLIP, VALVE GUIDE	1
5	GN-FYS76-M1-5	GASKET, CYLINDRE HEAD	1
6	GN-FYS76-M1-6	COVER COMP., HEAD	1
7	GN-FYS76-M1-7	PACKING, HEAD COVER	1
8	GN-FYS76-M1-8	TUBE BRAETHER	1
9	GN-FYS76-M1-9	BOLT, FLANGE, 6 X 12	4
10	GN-FYS76-M1-10	BOLT, STUD, 6 X 110	2
11	GN-FYS76-M1-11	BOLT, STUD, 8 X 32	2
12	GN-FYS76-M1-12	PIN, DOWEL, 8 X 60	2
13	GN-FYS76-M1-13	BOLT, FLANGE, 8 X 60	4
14	GN-FYS76-M1-14	PLUG, SPARK (F7tc)	1

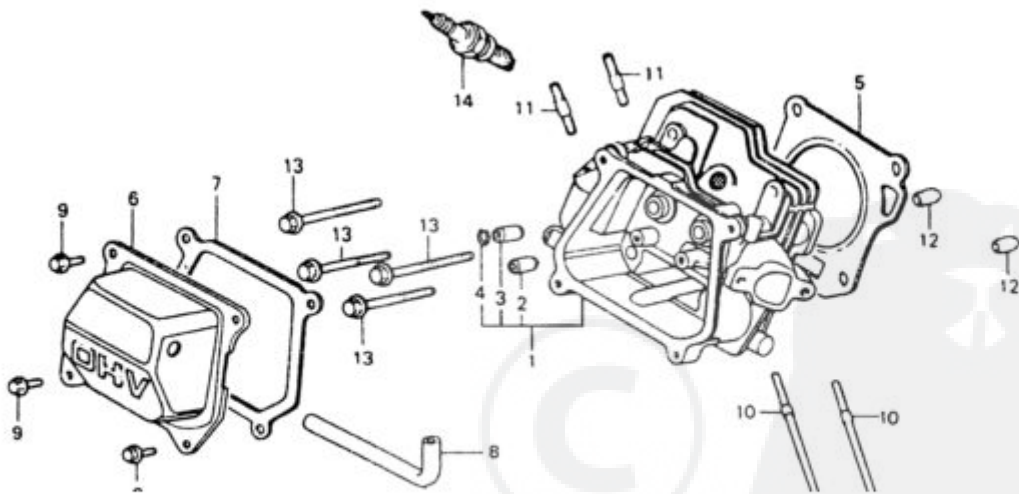

Fig. 2 Cylindre Barrel

Réf. N°	Part n°	Description	Qty.
1	GN-FYS76-M2-1	GOVERNOR KIT	1
2	GN-FYS76-M2-2	BARREL ASSY., CYLINDRE	1
3	GN-FYS76-M2-3	SWITCH ASSY., OIL LEVEL	1
4	GN-FYS76-M2-4	GOVERNOR ASSY.	1
5	GN-FYS76-M2-5	WEIGHT, GOVERNOR	2
6	GN-FYS76-M2-6	HOLDER, GOVERNOR WEIGHT	1
7	GN-FYS76-M2-7	PIN, GOVERNOR WEIGHT	2
8	GN-FYS76-M2-8	SLIVER, GOVERNOR	1
9	GN-FYS76-M2-9	SHAFT, GOVERNOR ARM	1
10	GN-FYS76-M2-10	BOLT, DRAIN PLUG	2
11	GN-FYS76-M2-11	WASHER, THRUST, 6mm	1
12	GN-FYS76-M2-12	WASHER, DRAIN PLUG, 10 mm	2
13	GN-FYS76-M2-13	CLIP, GOVERNOR HOLDER	1
14	GN-FYS76-M2-14	BEARING, RADIAL BALL 6205/P5	1
15	GN-FYS76-M2-15	OIL SEAL, 25 X 41 X 6	1
16	GN-FYS76-M2-16	O-RING, 14mm	1
17	GN-FYS76-M2-17	NUT, FLANGE, 10 mm	1
18	GN-FYS76-M2-18	WASHER, PLAIN, 6mm	2
19	GN-FYS76-M2-19	PIN, LOCK, 8mm	1
20	GN-FYS76-M2-20	BOLT, FLANGE, 6 X 12	2

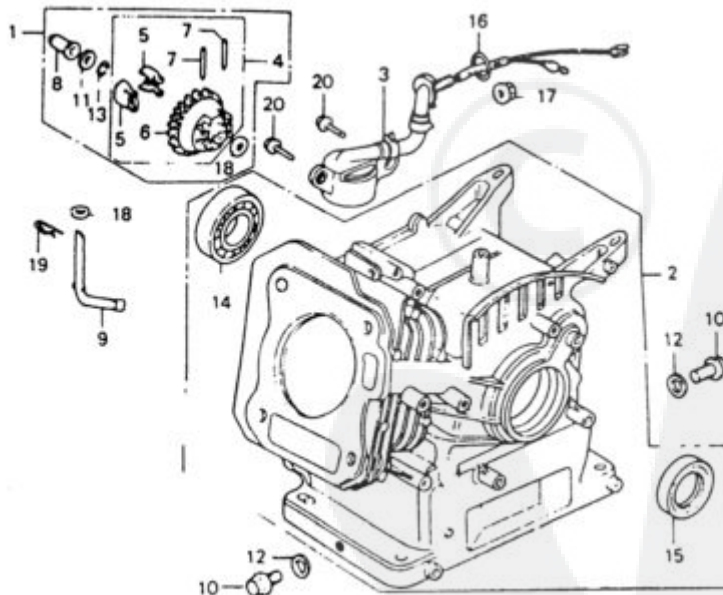

Fig. 3 Crankcase cover

Réf. N°	Part n°	Description	Qty.
1	GN-FYS76-M3-1	COVER ASSY., CRANKCASE	1
2	GN-FYS76-M3-2	PACKING, CASE COVER	1
3	GN-FYS76-M3-3	CAP ASSY., OIL FILLER	1
4	GN-FYS76-M3-4	CAP OIL HOLE	1
5	GN-FYS76-M3-5	PACKING, OIL FILLER CAP	1
6	GN-FYS76-M3-6	BOLT, FLANGE, 8 X 30	6
7	GN-FYS76-M3-7	BEARING, RADIAL BALL 6205/P5	2
8	GN-FYS76-M3-8	OIL SEAL, 25 X 41 X 6	1
9	GN-FYS76-M3-9	PIN, DOWEL, 8 X 14	4
10	GN-FYS76-M3-10	PACKING, CASE COVER	1
11	GN-FYS76-M3-11	COVER REDUCTION BOX	1
12	GN-FYS76-M3-12	BOLT, FLANGE, 6 X 25	5

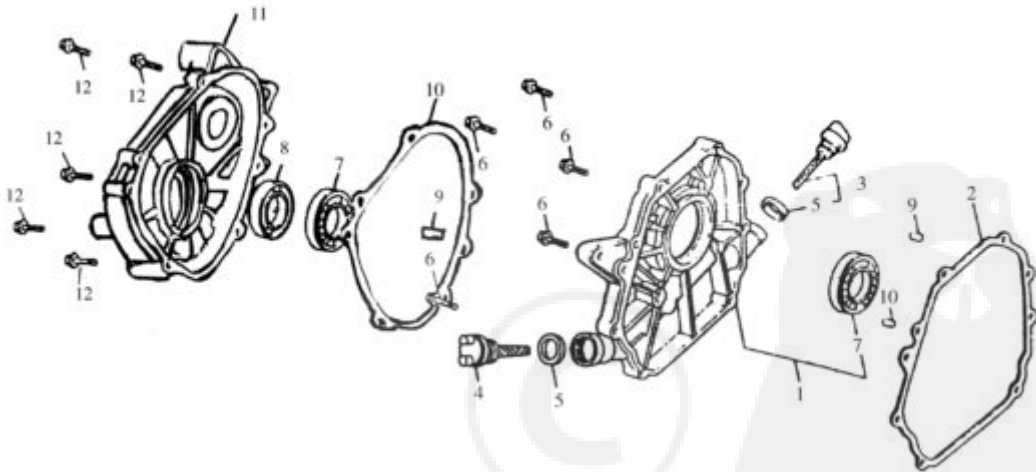

Fig. 4 Flywheel – ignition coil

Réf. N°	Part n°	Description	Qty.
1	GN-FYS76-M4-1	FAN, COOLING	1
2	GN-FYS76-M4-2	PULLEY, STARTER	1
3	GN-FYS76-M4-3	COIL ASSY., IGNITION	1
4	GN-FYS76-M4-4	TERMINAL ASSY., HIGH TENSION	1
5	GN-FYS76-M4-5	FLYWHEEL COMP.	1
6	GN-FYS76-M4-6	BOLT, FLANGE, 6 X 25	2
7	GN-FYS76-M4-7	NUT, SPECIAL, 14mm	1
8	GN-FYS76-M4-8	KEY, WOODRUFF,	1

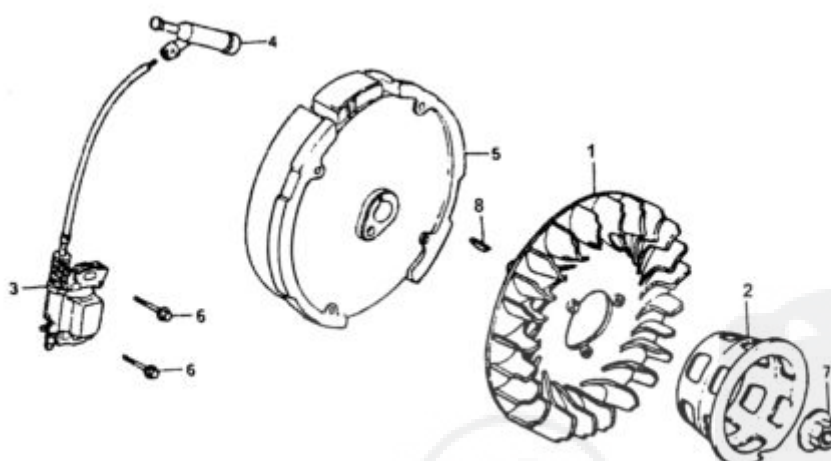

Fig. 5 Piston connecting rod – Crankshaft

Réf. N°	Part n°	Description	Qty.
1	GN-FYS76-M5-1	RING SET, PISTION	1
2	GN-FYS76-M5-2	PISTION	1
3	GN-FYS76-M5-3	PIN, PISTION	1
4	GN-FYS76-M5-4	ROD ASSY., CONNECTING	1
5	GN-FYS76-M5-5	CRANKSHAFT COMP.	1
6	GN-FYS76-M5-6	GEAR, TIMING	1
7	GN-FYS76-M5-7	GEAR, GOVERNOR DRIVE	1
8	GN-FYS76-M5-8	BOLT, CONNECTING ROD	1
9	GN-FYS76-M5-9	CLIP, PISTION PIN	2
10	GN-FYS76-M5-10	AXLE SLEEVE	1
11	GN-FYS76-M5-11	GEAR, CHAIN WHEEL	1
12	GN-FYS76-M5-12	WASHER	1
13	GN-FYS76-M5-13	BOLT, FLANGE, 8 X 20	1
14	GN-FYS76-M5-14	CHAIN AXLE	1
15	GN-FYS76-M5-15	CHAIN	1
16	GN-FYS76-M5-16	CHAIN	1
17	GN-FYS76-M5-17	GEAR, CHAIN WHEEL	1
18	GN-FYS76-M5-18	CHAIN AXLE	1

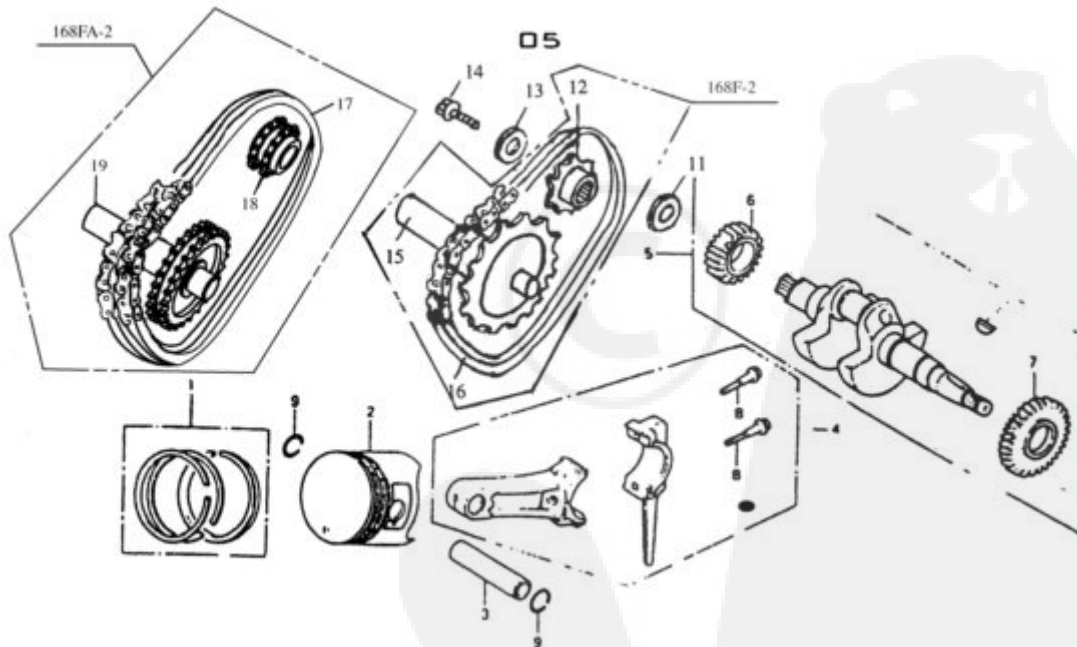

Fig. 6 Camshaft

Réf. N°	Part n°	Description	Qty
1	GN-FYS76-M6-1	CAMSHAFT ASSY.	1
2	GN-FYS76-M6-2	ROD, PUSH	2
3	GN-FYS76-M6-3	ARM, VALVE ROCKER	2
4	GN-FYS76-M6-4	LIFTER, VALVE	2
5	GN-FYS76-M6-5	PIVOT, ROCKER ARM	2
6	GN-FYS76-M6-6	SPRING, WEIGHT ARM	1
7	GN-FYS76-M6-7	VALVE, IN.	1
8	GN-FYS76-M6-8	VALVE, EX.	1
9	GN-FYS76-M6-9	SPRING, VALVE	2
10	GN-FYS76-M6-10	RETAINER, IN. VALVE SPRING	1
11	GN-FYS76-M6-11	RETAINER, EX. VALVE SPRING	1
12	GN-FYS76-M6-12	ROTATOR, VALVE	1
13	GN-FYS76-M6-13	PLATE, PUSH ROD GUIDE	1
14	GN-FYS76-M6-14	BOLT, PIVOT	2
15	GN-FYS76-M6-15	NUT, PIVOT ADJUSTING	2

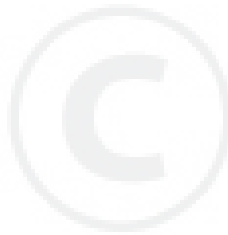
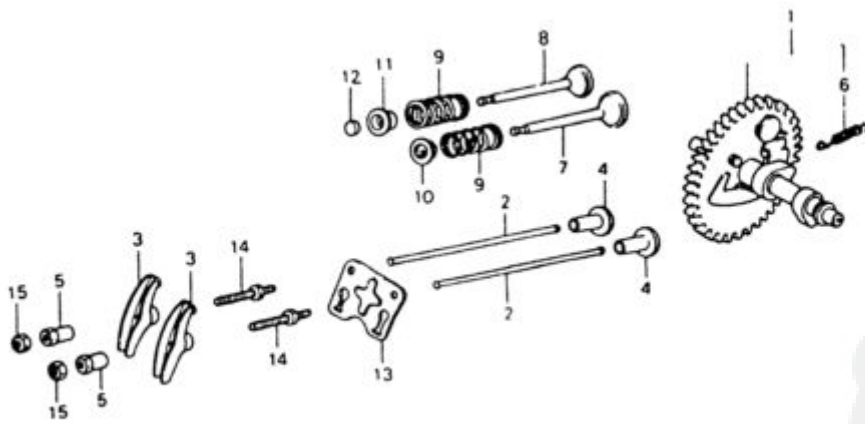



Fig. 7 Fan cover – Side plate

Réf. N°	Part n°	Description	Qty
1	GN-FYS76-M7-1	ALERT UNIT, OIL	1
2	GN-FYS76-M7-2	COVER COMP., FAN	1
3	GN-FYS76-M7-3	PLATE, SIDE	1
4	GN-FYS76-M7-4	SHROUD COMP.	1
5	GN-FYS76-M7-5	SWITCH ASSY., ENGINE STOP	1
6	GN-FYS76-M7-6	CORD, STOP SWITCH	1
7	GN-FYS76-M7-7	BOLT, FLANGE, 6 X 12	6
8	GN-FYS76-M7-8	BOLT, FLANGE, 6 X 20	1
9	GN-FYS76-M7-9	BOLT, FLANGE, 6 X 10	1

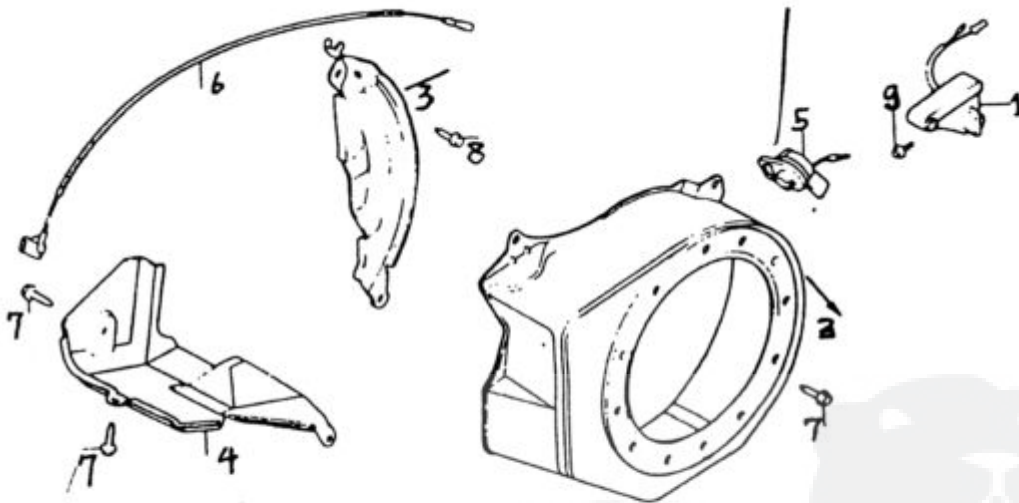

Fig. 8 Recoil starter

Réf. N°	Part n°	Description	Qty
1	GN-FYS76-M8-1	STARTER ASSY., RECOIL	1
2	GN-FYS76-M8-2	CASE COMP., RECOIL STARTER	1
3	GN-FYS76-M8-3	PULLEY, RECOIL STARTER	1
4	GN-FYS76-M8-4	RATCHET, STARTER	1
6	GN-FYS76-M8-6	PLATE, FRICTION	1
7	GN-FYS76-M8-7	SPRING, FRICTION	1
8	GN-FYS76-M8-8	SPRING, RECOIL STARTER	
9	GN-FYS76-M8-9	GUIDE, RATCHET	1
10	GN-FYS76-M8-10	CASE, RECOIL STARTER SPRING	1
11	GN-FYS76-M8-11	WASHER, STARTER	1
12	GN-FYS76-M8-12	SHAFT, SUB	1
13	GN-FYS76-M8-13	BOLT, FLANGE, 6 X 8	1
14	GN-FYS76-M8-14	KNOB, RECOIL STATER	1
15	GN-FYS76-M8-15	ROPE, RECOIL STATER	1
16	GN-FYS76-M8-16	EMBLEM (EXTERNAL)	1
17	GN-FYS76-M8-17	BOLT, FLANGE, 6 X 10	3

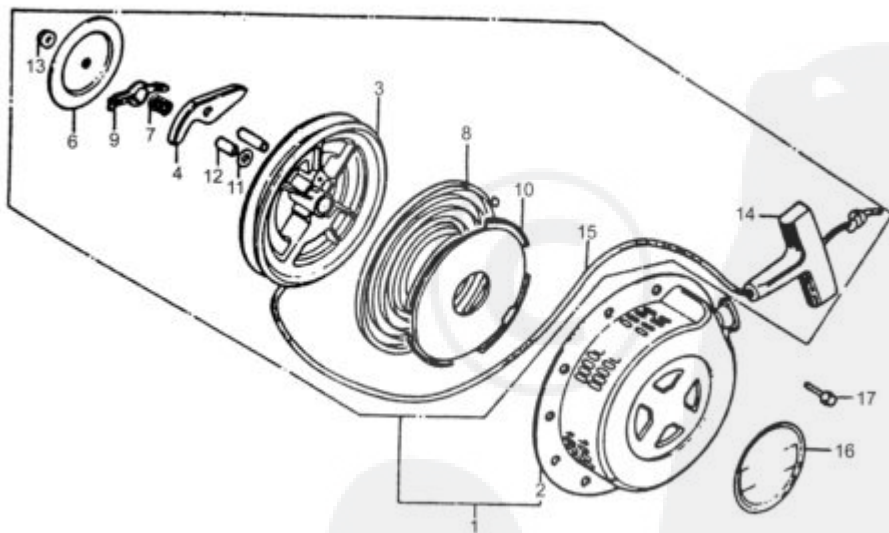

Fig. 9 Control

Réf. N°	Parts n°	Description	Qty
1	GN-FYS76-M9-1	ARM, GOVERNOR	1
2	GN-FYS76-M9-2	ROD, GOVERNOR	1
3	GN-FYS76-M9-3	SPRING, GOVERNOR	1
4	GN-FYS76-M9-4	SPRING, THROTTLE RETURN	1
5	GN-FYS76-M9-5	CONTROL ASSY.	1
6	GN-FYS76-M9-6	LEVER, CONTROL	1
7	GN-FYS76-M9-7	SPRING, LEVER	1
8	GN-FYS76-M9-8	WASHER, CONTROL LEVER	1
9	GN-FYS76-M9-9	SPARCER, CONTROL LEVER	1
10	GN-FYS76-M9-10	BASE COMP., CONTROL	1
11	GN-FYS76-M9-11	SPRING? CONTROL ADJUSTING	1
12	GN-FYS76-M9-12	BOLT, FLANGE, 6 X 12	1
13	GN-FYS76-M9-13	BOLT, GOVERNOR ARM.	1
14	GN-FYS76-M9-14	BOLT, FLANGE, 6 X 20	1
15	GN-FYS76-M9-15	NUT SELF LOCK, 6 mm	1
16	GN-FYS76-M9-16	BOLT, HEX., 6 X 20	1
17	GN-FYS76-M9-17	SCREW, PAN, 5 X 20	1
18	GN-FYS76-M9-18	NUT, FLANGE, 6 mm	1

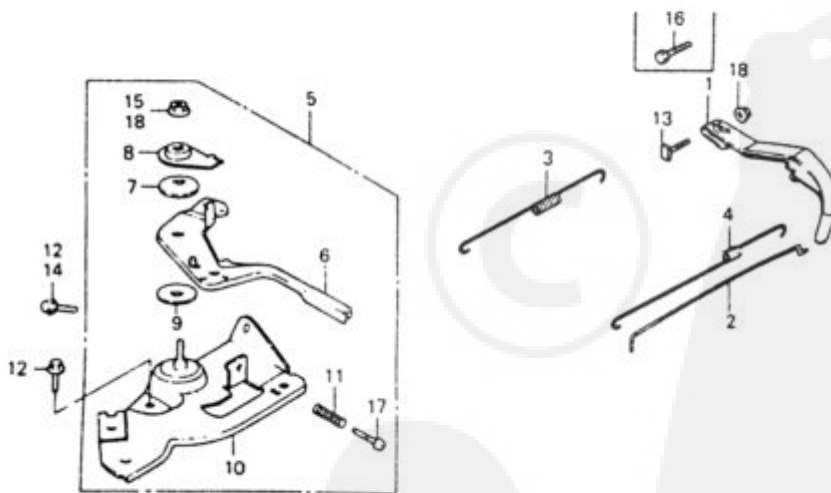

Fig. 10 Carburator

Réf. N°	Part n°	Description	Qty
1	GN-FYS76-M10-1	GASKET SET	1
2	GN-FYS76-M10-2	VALVE SET, FLOAT	1
3	GN-FYS76-M10-3	FLOAT SET	1
4	GN-FYS76-M10-4	CHAMBER SET, FLOAT	1
5	GN-FYS76-M10-5	SCREW SET, PIOLT	1
6	GN-FYS76-M10-6	SCREW SET, DRAIN	1
7	GN-FYS76-M10-7	SCREW SET	1
8	GN-FYS76-M10-8	CHOKE SET	1
9	GN-FYS76-M10-9	CARBURATOR ASSY.	1
10	GN-FYS76-M10-10	SCREW, THROTTLE STOP	1
11	GN-FYS76-M10-11	NOZZLE, MAIN	1
12	GN-FYS76-M10-12	PACKING, FULE STRAINER CUP	1
13	GN-FYS76-M10-13	INSULATOR, CARBURATOR	1
14	GN-FYS76-M10-14	PACKING, INSULATOR	1
15	GN-FYS76-M10-15	SPACER COMP. CARBURATOR	1
16	GN-FYS76-M10-16	PACKING, CARBURATOR	1
17	GN-FYS76-M10-17	LEVER COMP. CHOKE	1
18	GN-FYS76-M10-18	LEVER COCK	1
19	GN-FYS76-M10-19	PLATE, LEVER SETTING	1
20	GN-FYS76-M10-20	SPRING, COCK LEVER	1
21	GN-FYS76-M10-21	PAKING, FULE COCK	1
22	GN-FYS76-M10-22	CUP, FULE STRAINER	1
23	GN-FYS76-M10-23	SCREW, PAN, 3 X 8	2
24	GN-FYS76-M10-24	PIN, SPRING	1
25	GN-FYS76-M10-25	JET, MAIN	1
26	GN-FYS76-M10-26	JET SET, PILOT	1

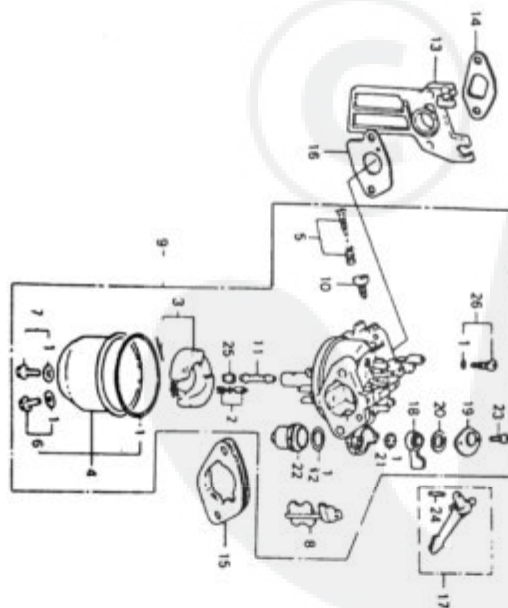

Fig. 11 Air cleaner

Réf. N°	Part n°	Description	Qty
1	GS-FYS76-M11-1	ELEMENT, AIR CLEANER	1
2	GS-FYS76-M11-2	GRID, AIR CLEANER	1
3	GS-FYS76-M11-3	COVER, AIR CLEANER	1
4	GS-FYS76-M11-4	COLLAR, AIR CLEANER	2
5	GS-FYS76-M11-5	COLLAR B, AIR CLEANER	1
6	GS-FYS76-M11-6	ELBOW COMP., AIR CLEANER	1
7	GS-FYS76-M11-7	CAP, CLEANER	1
8	GS-FYS76-M11-8	MARK, CHOKE	1
9	GS-FYS76-M11-9	NUT, CUP, 6 mm	2
10	GS-FYS76-M11-10	NUT, AIR CLEANER	1
11	GS-FYS76-M11-11	COVER BOLT - WASHER, 6 X 20	1

