

GN-FYS76 (2013)

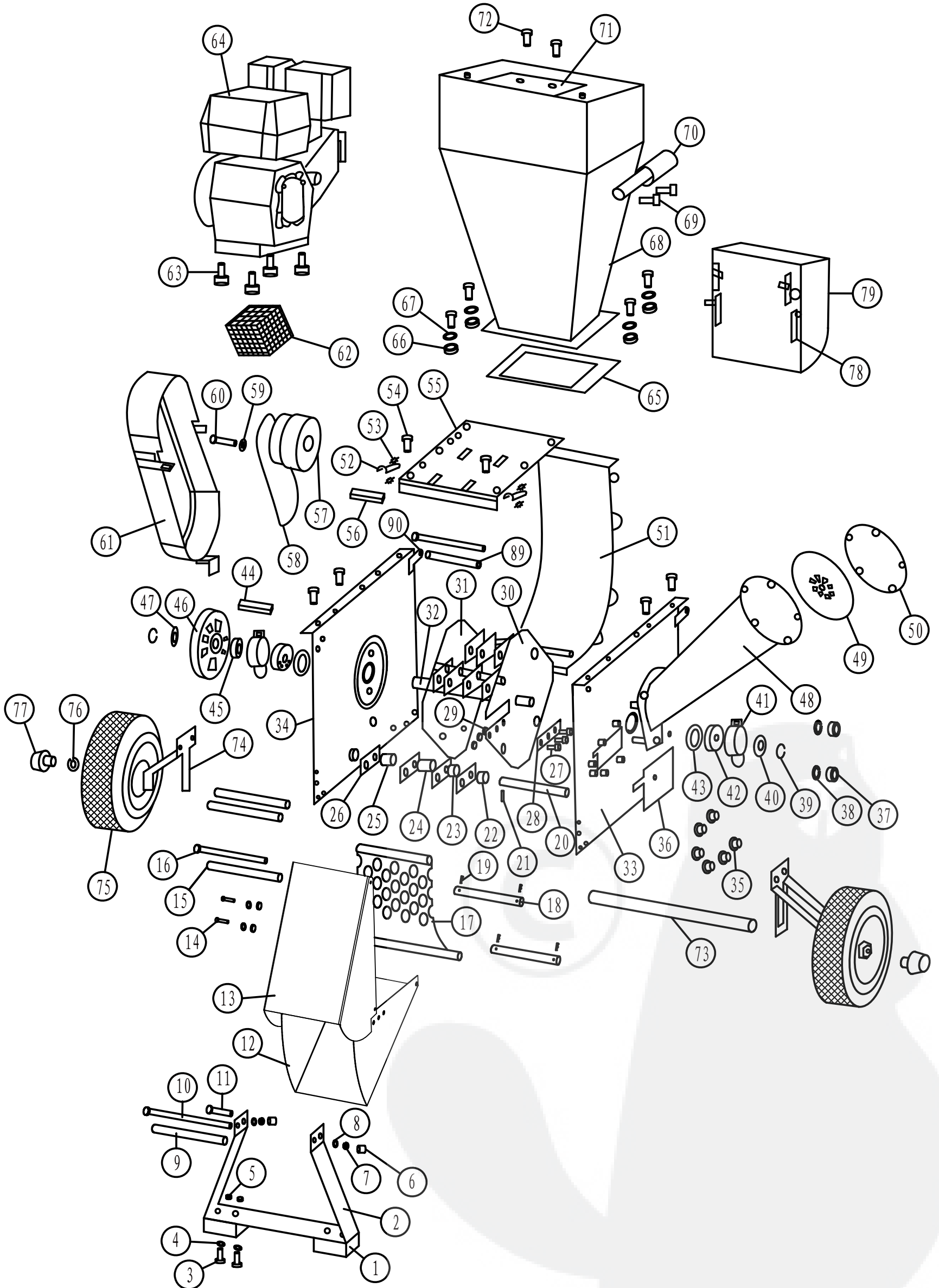

No.	Référence	Description	Qty	No.	Référence	Description	Qty
1	GN-FYS76-1-13	rubber foot	2	41	GN-FYS76-41-13	bearing seat	2
2	GN-FYS76-2-13	leg	1	42	GN-FYS76-42-13	ball bearing	2
3	GN-FYS76-3-13	inner hexagon screw	4	43	GN-FYS76-43-13	bearing washer	2
4	GN-FYS76-4-13	flat washer	10	44	GN-FYS76-44-13	flat key	1
5	GN-FYS76-5-13	locknut	10	45	GN-FYS76-45-13	washer (right)	1
6	GN-FYS76-6-13	nut	26	46	GN-FYS76-46-13	pulley	1
7	GN-FYS76-7-13	spring washer	31	47	GN-FYS76-47-13	spacer	1
8	GN-FYS76-8-13	flat gasket	47	48	GN-FYS76-48-13	chipping chute	1
9	GN-FYS76-9-13	tube	1	49	GN-FYS76-49-13	rubber blanket	1
10	GN-FYS76-10-13	hex bolt	3	50	GN-FYS76-50-13	pressing ring	1
11	GN-FYS76-11-13	hex bolt	18	51	GN-FYS76-51-13	rear board	1
12	GN-FYS76-12-13	discharge chute	1	52	GN-FYS76-52-13	bag hook	2
13	GN-FYS76-13-13	baffle plate	1	53	GN-FYS76-53-13	lock washer	4
14	GN-FYS76-14-13	cruciform slot screw	4	54	GN-FYS76-54-13	hex bolt	2
15	GN-FYS76-15-13	tube	3	55	GN-FYS76-55-13	engine lock plate	1
16	GN-FYS76-16-13	hex bolt	3	56	GN-FYS76-56-13	flat key	1
17	GN-FYS76-17-13	screen	1	57	GN-FYS76-57-13	clutch	1
18	GN-FYS76-18-13	long pin	2	58	GN-FYS76-58-13	V-belt	1
19	GN-FYS76-19-13	B-pin	4	59	GN-FYS76-59-13	clutch gasket	1
20	GN-FYS76-20-13	hammer axle	4	60	GN-FYS76-60-13	hex bolt	5
21	GN-FYS76-21-13	roll pin	4	61	GN-FYS76-61-13	pulley cover	1
22	GN-FYS76-22-13	spacer I	4	62	GN-FYS76-62-13	burn-proof net	1
23	GN-FYS76-23-13	spacer II	4	63	GN-FYS76-63-13	anti-rotating bolt	4
24	GN-FYS76-24-13	spacer III	8	64	GN-FYS76-64-13	engine	1
25	GN-FYS76-25-13	spacer VI	4	65	GN-FYS76-65-13	flange rubber pad	1
26	GN-FYS76-26-13	hammer	16	66	GN-FYS76-66-13	buffer washer	4
27	GN-FYS76-27-13	flat HD SCR	3	67	GN-FYS76-67-13	flat washer	8
28	GN-FYS76-28-13	blade	2	68	GN-FYS76-68-13	hopper	1
29	GN-FYS76-29-13	locknut	20	69	GN-FYS76-69-13	cruciform slot screw	4
30	GN-FYS76-30-13	main impeller	1	70	GN-FYS76-70-13	handle	2
31	GN-FYS76-31-13	auxiliary impeller	1	71	GN-FYS76-71-13	PP plate	1
32	GN-FYS76-32-13	impeller axle	1	72	GN-FYS76-72-13	cruciform slot screw	2
33	GN-FYS76-33-13	box frame side left	1	73	GN-FYS76-73-13	wheel axle	1
34	GN-FYS76-34-13	box frame side right	1	74	GN-FYS76-74-13	wheel support	2
35	GN-FYS76-35-13	flange nut	6	75	GN-FYS76-75-13	wheel	2
36	GN-FYS76-36-13	blade cover plate	1	76	GN-FYS76-76-13	spring washer	2
37	GN-FYS76-37-13	nut	4	77	GN-FYS76-77-13	wheel knob	2
38	GN-FYS76-38-13	spring washer	4	78	GN-FYS76-78-13	tool box leg	2
39	GN-FYS76-39-13	wire circlip	2	79	GN-FYS76-79-13	tool box	1
40	GN-FYS76-40-13	washer (left)	1				