

REF No.	CODE	NAME	QTY	REMARKS
1		SHAFT SET	1	24
2		HANDLE SET	1	W type
3	800200083	HANDLE DAMPER	1	for 24
4	801689262	WIRE GUIDE	2	for 24
5	800200000	HANGER STRAP STEM	1	for 24
6	800200001	SCREW	1	M6 × 12 (+)2P
7	801667186	HARNES ASSY	1	Sing belt
8	800200380	LABEL	1	178 × 35 PL
9	800204466	LABEL	1	106 × 20 CE08
10	800204454	LABEL	1	53 × 20 Model+dB
11	800201167	LABEL	1	143 × 29 MARUNAKA
12	800204464	LABEL	1	Φ 20 Made in Japan
13	801688381	EYE PROTECTOR	1	
14	800200023	SPANNER	1	10 × 8
15	800200022	SPANNER	1	#4
16	800200042	SPANNER	1	#5
17	801689042	SPANNER	1	13 × 19
18	800200113	SPANNER	1	16 × 19
19	800200111	CABLE ASSY	1	80mm
20	800200034	SCREW	1	M5 × 10(+)2P
21	800200511	PROTECTOR	2	1Set
22	801689082	BAG	1	82 × 60
23	800200025	BAG	1	118 × 168
24	800200026	BAG	1	370 × 270
25	800204407	MANUAL	1	A4

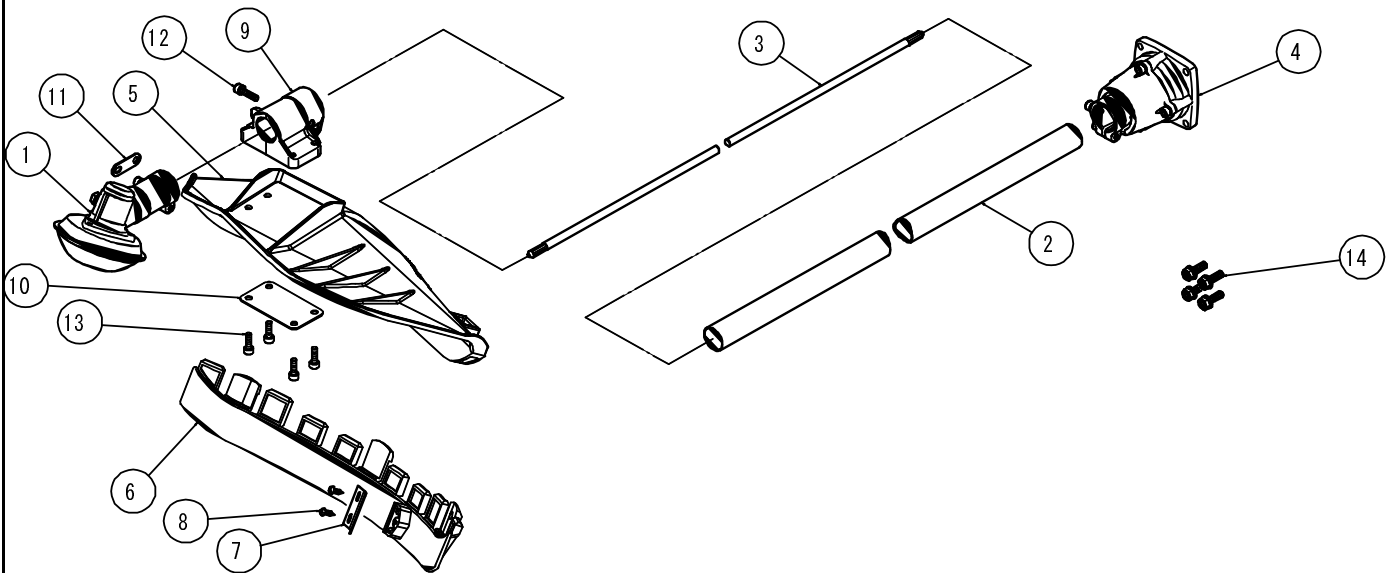

REF No.	CODE	NAME	QTY	REMARKS
	800204405	SHAFT SET	1	24
1	801675691	GEAR CASE ASS'Y	1	for 24
2	800200557	DRIVE SHAFT HOUSING ASS'Y	1	$\phi 24 \times 1550$
2,1	800200485	800200557 DRIVE SHAFT HOUSING	1	$\phi 24 \times t1.5 \times 1550$
2.2	801675694	METAL CUSHION	6	
2.3	801675695	OIL METAL	6	$\phi 7 \times \phi 14 \times 12$
3	801698764	DRIVE SHAFT	1	$\phi 7 \times 1593$
4	800200544	CLUTCH CASE ASSY	1	
5	800205017	SAFETY GUARD	1	393 × 236 × 92
6	800201974	SAFETY GUARD ASSY	1	
6.1	800201971	800201974 SAFETY GUARD	1	415 × 24 × 67
6.2	800201973	SCREW	1	M4 × 10(+)3P
6.3	800200553	NUT	1	M4 Type1
7	800201972	CUTTER	1	38 × 31.7 × t1
8	800200460	SCREW	2	#4 × 12(+) 2P
9	800204578	SAFETY GUARD HOLDER	1	for 24
10	800204580	SAFETY GUARD HOLDER	1	72 × 40 × t1.5
11	801675703	CONNECTOR	1	35 × 12 × t1.5
12	800200012	CAP BOLT	1	M5 × 20
13	800200013	CAP BOLT	4	M5 × 16
14	800200011	BOLT	4	M6 × 20 (+)3P

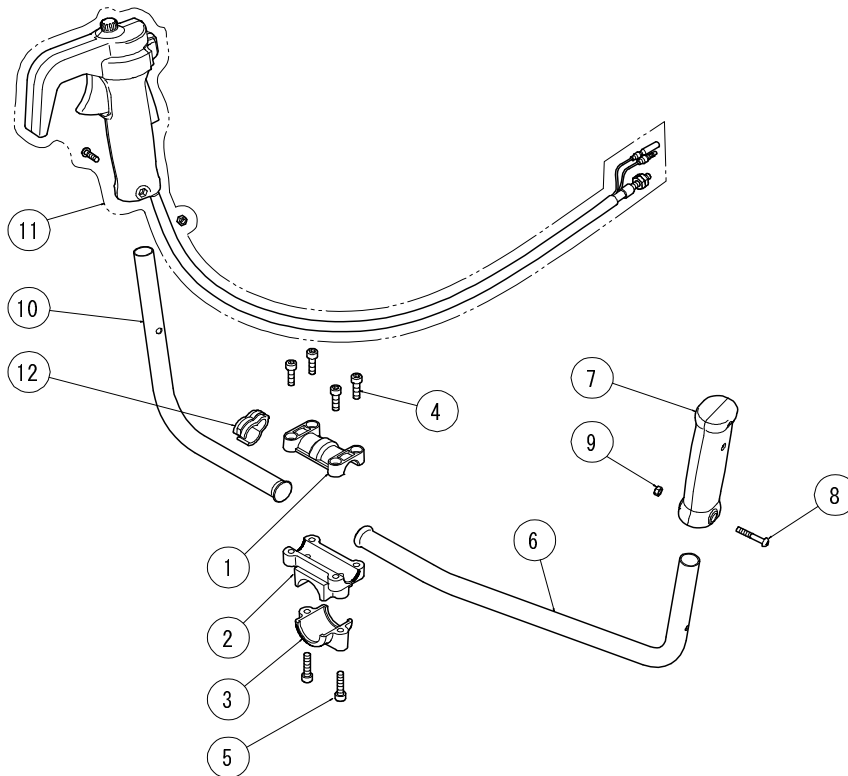

REF No.	CODE	NAME	QTY	REMARKS
	800204408	HANDLE SET	1	W type
1	801689441	HANDLE HOLDER	1	for 19
2	801689443	HANDLE HOLDER	1	for 19
3	801675715	HANDLE HOLDER	1	
4	800200038	BOLT	4	M6×20
5	800200039	BOLT	2	M6×25
6	800200505	HANDLE	1	φ 19.1×t1.2 LEFT
7	801655825	GRIP ASSY	1	
8	800203739	SCREW	1	M5×30(+/-)
9	800201048	NUT	1	M5
10	800200506	HANDLE	1	φ 19.1×t1.2 RIGHT
11	801695931	THROTTLE LEVER ASSY	1	
12	801675722	WIRE GUIDE	1	for 19

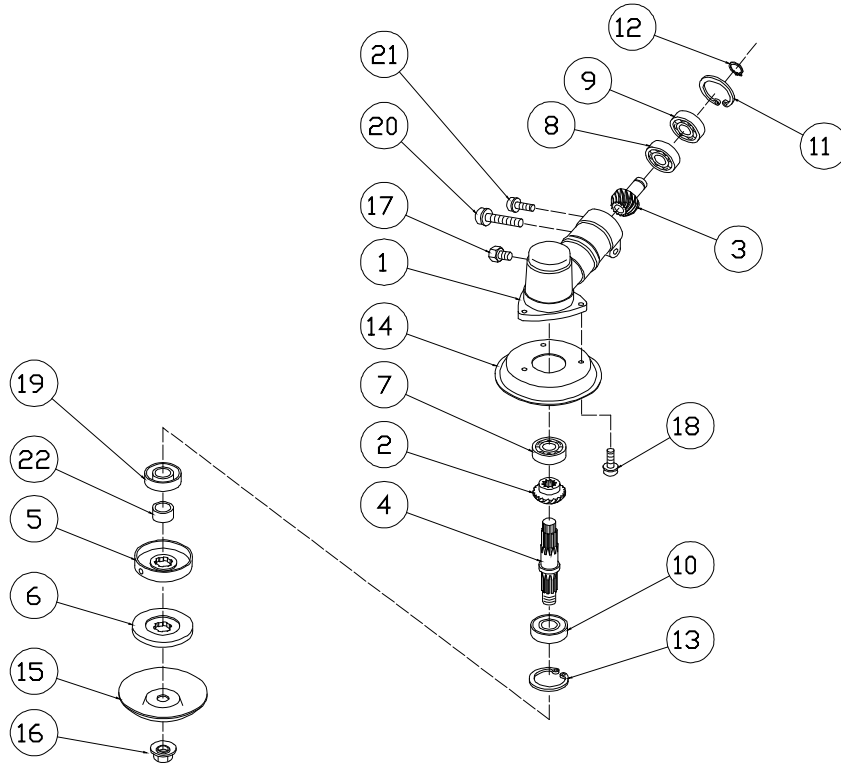

REF No.	CODE	NAME	QTY	REMARKS
	801675691	GEAR CASE ASS'Y	1	24
1	801676347	GEAR CASE	1	24
2	801676348	BEVEL GEAR	1	
3	801676349	PINION	1	
4	801676350	GEAR SHAFT	1	
5	801676351	HOLDER(A)	1	
6	801676352	HOLDER(B)	1	
7	801676353	BEARING	1	608
8	801676354	BEARING	1	609
9	801676355	BEARING	1	609Z
10	800045130	BEARING	1	6001
11	800080430	STOP RING	1	24
12	800082220	STOP RING	1	9
13	800083170	STOP RING	1	28
14	801676357	GEAR CASE COVER	1	$\phi 35 \times \phi 88$
15	801676358	NUT COVER	1	$\phi 8 \times \phi 79.5$
16	801676359	NUT	1	M8 \times 1.25
17	800010505	BOLT	1	M6 \times 8
18	801676360	SCREW	1	M4 \times 8(+) 2P
19	801676361	OIL SEAL	1	TC17287
20	801676362	CAP BOLT	1	M5 \times 25 2P
21	801676363	CAP BOLT	1	M5 \times 8 2P
22	801676364	COLLAR	1	$\phi 12 \times \phi 17 \times 9.5$

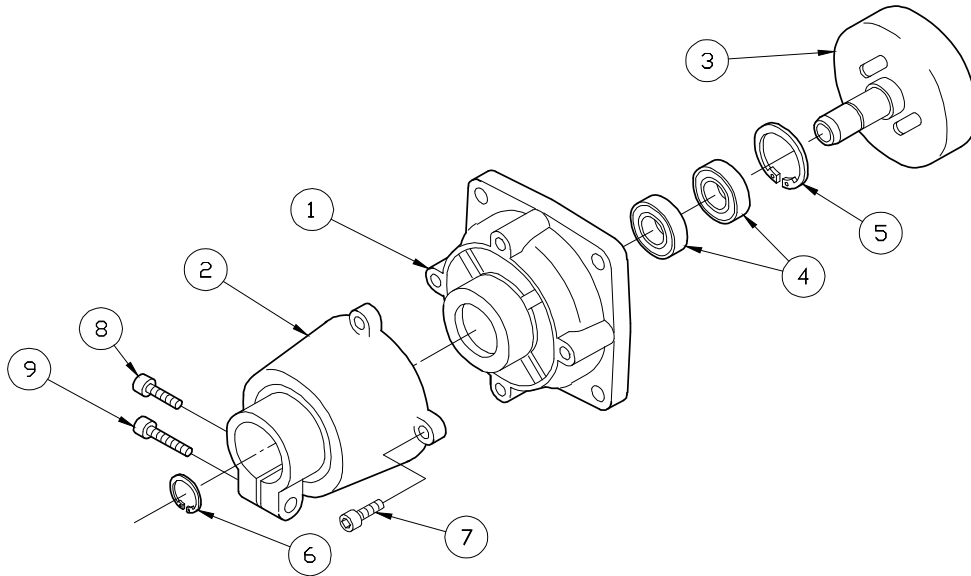

REF No.	CODE	NAME	QTY	REMARKS
	800200544	CLUTCH HOUSING ASS'Y	1	24
1	800200497	CLUTCH HOUSING	1	
2	800200501	CLUTCH HOUSING ASS'Y	1	
3	800200538	CLUTCH DRUM	1	φ 54
4	801676309	BEARING	2	6001ZZ
5	800200539	STOP RING	1	C-28
6	800200540	STOP RING	1	S-12
7	800200541	CAP BOLT	4	M5 × 14 2P
8	800200542	CAP BOLT	1	M5 × 12 2P
9	800200543	CAP BOLT	1	M5 × 20 2P