

PowerBroom 24.2mm Conversion Kit

P/N 99909-22000

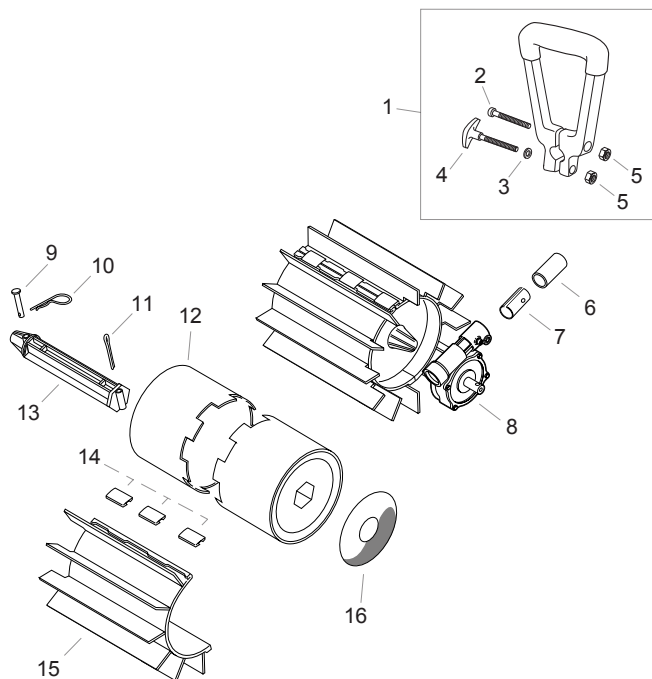

NO.	PART NUMBER	DESCRIPTION	QTY.
1	72951-14100	HANDLE ASSY	1
2	72030-14141	*BOLT	1
3	72030-14130	*WASHER	1
4	72030-14120	*KNOB	1
5	01500-06051	*NUT	2
6	99909-33034	TUBE PROTECTOR 24MM	1
7	72959-13330	COLLAR	1
8	44444	GEARCASE ASSY 40:1	1
9	99909-33118	CLEVIS PIN	2
10	99909-33008	HITCH PIN	2
11	99909-33020	COTTER PIN	2
12	99909-33004	DRUM HUB	4
13	99909-33116	DRUM AXLE	2
14	99909-33007	BELT CLIP	12
15	99909-33005	BELT	4
16	61215	POWERBROOM DRUM LABEL	2

PowerBroom 26mm Conversion Kit

P/N 99909-33000

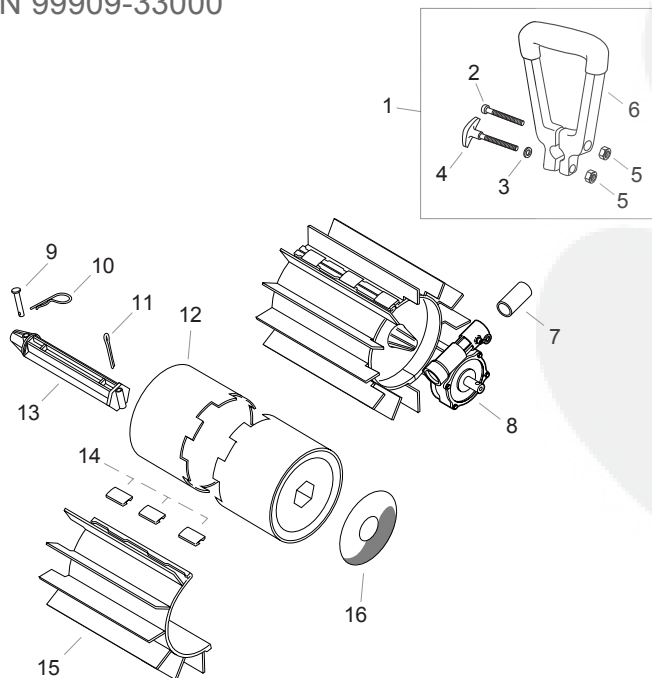

NO.	PART NUMBER	DESCRIPTION	QTY.
1	99909-33009	HANDLE ASSY	1
2	72030-14141	*BOLT	1
3	72030-14130	*WASHER	1
4	72030-14120	*KNOB	1
5	01500-06051	*NUT	2
6	72953-14110	*HANDLE	1
7	99909-33033	TUBE PROTECTOR 25MM	1
8	33333	GEARCASE ASSY 40:1	1
9	99909-33118	CLEVIS PIN	2
10	99909-33008	HITCH PIN	2
11	99909-33020	COTTER PIN	2
12	99909-33004	DRUM HUB	4
13	99909-33116	DRUM AXLE	2
14	99909-33007	BELT CLIP	12
15	99909-33005	BELT	4
16	61215	POWERBROOM DRUM LABEL	2

PowerBroom Shindaiwa Gearcase Assembly 33333

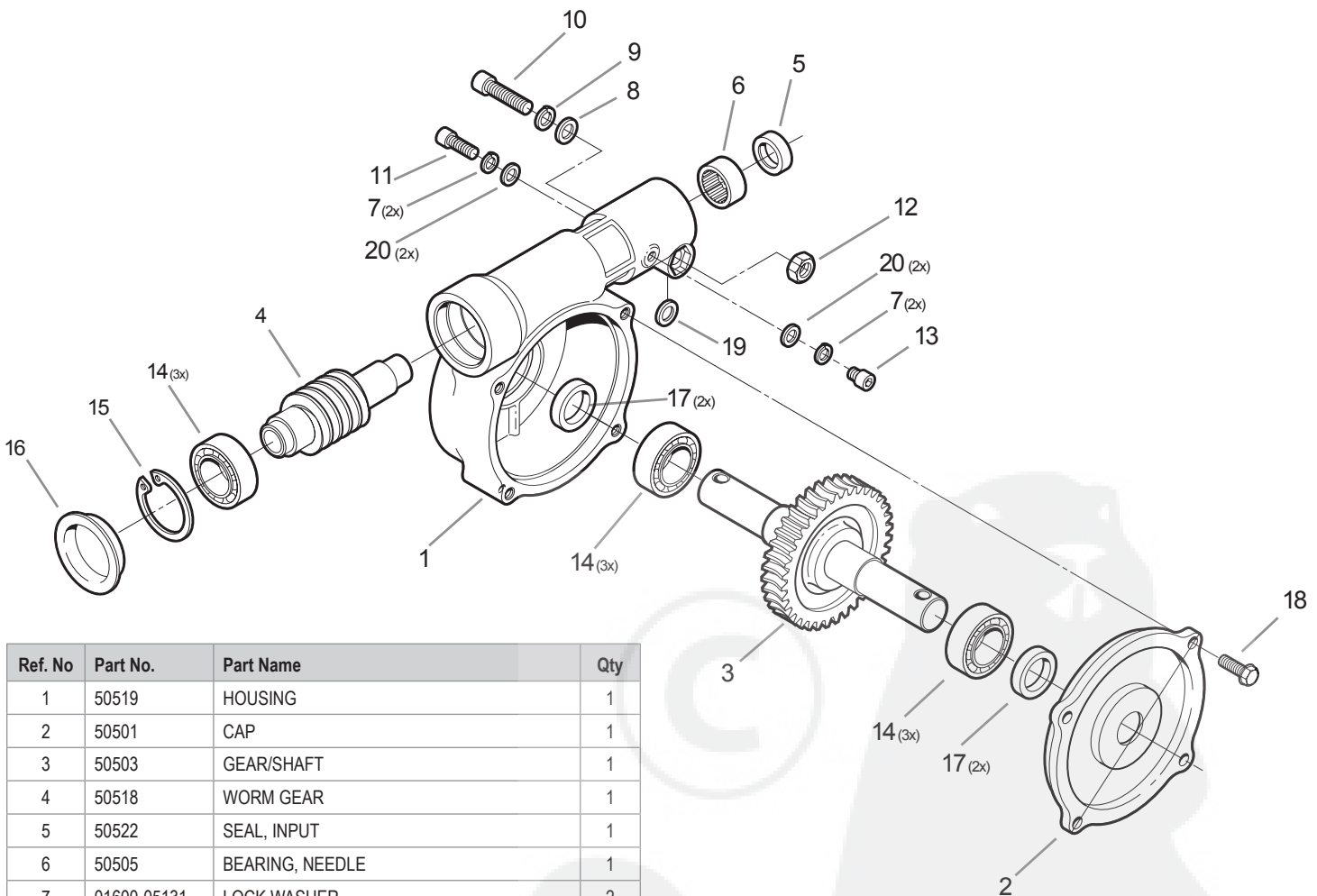

Ref. No	Part No.	Part Name	Qty
1	50519	HOUSING	1
2	50501	CAP	1
3	50503	GEAR/SHAFT	1
4	50518	WORM GEAR	1
5	50522	SEAL, INPUT	1
6	50505	BEARING, NEEDLE	1
7	01600-05131	LOCK WASHER	2
8	50509	WASHER, FLAT	1
9	50511	WASHER, LOCK	1
10	50507	SCREW	1
11	01020-05120	SCREW	1
12	50510	NUT	1
13	50520	BOLT	1
14	50506	BEARING	3
15	50512	RETAINING RING	1
16	50502	PLUG	1
17	50523	SEAL, OUTPUT	2
18	50508	SCREW, COVER	4
19	50509	SHIM	1
20	01610-05080	WASHER, FLAT	2