

**(D)** *Ersatzteilliste*     **Motorsense**     **154**

Inhaltsverzeichnis	Seite
Motor, Kurbelwelle	2
Luftfilter, Vergaser, Auspuff	4
Zündung, Motor-Abdeckhaube	6
Benzintank	7
Starter	8
Schaftrohr, Alu-Profil	9
Bikegriff, Gasbetätigung	10
Getriebe, Schutz	11
Werkzeug, Zubehör	12
Richtlinien für die Bestellung	13
Ersatzteile	14

**(GB)** *Spare parts list*     **Brushcutter**     **154**

Table of contents	Page
Engine,crankshaft	2
Air filter, carburetor, exhaust	4
Ignition, cover	6
Fuel tank	7
Starter	8
Shaft tube, profile	9
Handle, throttle control	10
Gear, protection	11
Tools, accessories	12
Directions for ordering	13
Spare parts	14

**(F)** *Liste de pièces de rechange*     **Debroussailleuses**     **154**

Table des matières	Page
Moteur, villebrequin	2
Filtre à air, carburateur, echappement	4
Allumage, capot	6
Réservoir à essence	7
Lanceur	8
Tube, p rofil	9
Poignée, levier de réglage	10
Engrenage, protection	11
Outillage, accesories	12
Directives pour les comandes	13
Pièces de rechange	14

**(E)** *Lista de piezas de recambio*     **Desbrozadora**     **154**

Indice	Página
Motor, cigüñeal	2
Filtro de aire, carburador, escape	4
Encendido, cubierta	6
Deposito	7
Arranque	8
Tubo, p erfil	9
Tubo, acelerador de gas	10
Engranaje, proteccion	11
Herramientas, accesorios	12
Directivas de pedido	13
Piezas de recambio	14



Bild-Nr. Pos.-No. No.Pos. Pos.-No.	Bestell-Nr. Order-No. No. de Cde Ref.-Nr.	Menge Quantity Nombres Cantidad	Motor, Kurbelwelle	Engine, crankshaft	Moteur, vile brequin	Motor, cigüñeal
1	20 00 355	1	Motor komplett	Engine	Moteur	Motor
2	20 11 144	1	Kurbelgehäuse	Crankcase	Carter moteur	Carter cigüñeal
3	22 00 142	1	Kurbelwelle	Crankshaft	Vilebrequin	Cigüñeal
4	33 00 143	2	Lagerhülse 34,9x45,17x18,8 mm, Reparaturatz	Sleeve, repair kit	Douille, kit de réparation	Casquillo, juego de reparacion
5	00 31 206	2	Scheibe 15x21x0,3 mm	Washer	Rondelle	Arandela
6	22 00 158	1	Zylinder + Kolben, Reparaturatz enth.: (-> 6 - 15	Cylinder + piston, repair kit incl. (-> 6 - 15	Cylindre + piston, kit de réparation y inclus (-> 6 - 15	Cilindro + piston, juego de reparacion incl. (-> 6 - 15
8	20 63 133	1	Dichtungsteil	Sealing	Joint carter moteur	Junta
9	20 63 134	1	Dichtungsteil	Sealing	Joint carter moteur	Junta
11	22 00 159	1	Kolben Ø 45 mm enth.: (-> 11-14	Piston incl. (-> 11 - 14	Piston y inclus (-> 11 - 14	Piston incl. (-> 11 - 14
12	20 48 357	2	Kolbenring 45x1,5 mm	Piston ring	Segment de piston	Anillo de piston
13	00 55 267	2	Sicherungsring 10x0,8 mm	Circlip	Arrêt axe de piston	Anillo de seguridad
14	20 31 249 25	1	Kolbenbolzen 10/6x28 mm (-)	Piston pin (-)	Axe de piston (-)	Perno de embolo (-)
15	00 52 255	1	Nadelkäfig 10x14x13 mm (-)	Needle sleeve (-)	Douille (-)	Casquillo (-)
17	00 18 337	4	Zylinderschraube M5x20 mm	Screw	Vis	Tornillo
19	20 74 106 25	1	Widerlager	Counter bearing	Roulement butée	Cojinete de tope
20	00 72 140	1	Scheibe 5,2x12x0,5 mm	Washer	Rondelle	Arandela
21	00 18 335	1	Zylinderschraube. M5x12 mm	F.H. screw	Vis	Tornillo
22	28 00 570	1	Dekoventil	Deco-valve	Soupape decompression	Valvula
23	00 75 101	1	Scheibenfeder 3x3,7 mm	Spring	Clavette	Resorte
24	24 00 154	1	Lüfterrad	Fan wheel	Turbine	Turbina
25	00 72 145	1	Spannscheibe 8 mm	Washer	Rondelle	Arandela
26	00 20 145	1	Sechskantmutter M8x1 mm	Hex. nut	Ecrou	Tuerca
27	30 16 154	1	Kupplungsträger			
28	00 72 149	2	Tellerfeder 8,2x16x0,4 mm	Spring	Rondelle	Resorte
29	35 00 130	1	Fliehkraftkupplung enth. (-> 29, 30	Centrifugal clutch incl. (-> 29, 30	Embrayage centrifuge y inclus (-> 29, 30	Embrague centrifugal incl. (-> 29, 30
30	00 71 154	1	Kupplungsfeder ->)	Spring ->)	Ressort ->)	Resorte ->)
31	00 72 174	2	Tellerfeder 10,2x20x0,5 mm	Spring	Rondelle	Resorte
32	00 18 114	2	Sechskantschraube M8x20 mm	Screw	Vis	Tornillo
33	26 00 132	1	Starter komplett	Starter cpl.	Lanceur cpl.	Arranque cpl.
34	00 18 337	2	Zylinderschraube M5x20 mm	Screw	Vis	Tornillo
35	00 18 338	1	Zylinderschraube M5x25 mm	Screw	Vis	Tornillo
36	21 00 162	1	Flanschgehäuse enth. (-> 36 - 44	Flange housing incl. (->36 - 44	Boîtier bride y inclus (->36 - 44	Caja de brida incl. (->36 - 44
37	00 50 250	1	Kugellager 17x40x12 mm	Ball bearing	Roulement à bille	Cojinete de bolas
38	00 55 113	1	Sicherungsring 40x1,75 mm	Circlip	Arrêt axe de piston	Anillo de seguridad
39	35 00 136	1	Kupplungsglocke 78mm 9Zähne	Clutch drum	Cloche d'embrayage	Campana de embrague
40	00 55 105	1	Sicherungsring 17x1 mm	Circlip	Arrêt axe de piston	Anillo de seguridad
41	00 18 349	1	Zylinderschraube M6x30 mm	F.H. screw	Vis	Tornillo
42	00 18 405	1	Zylinderschraube M5x14,5 mm	F.H. screw	Vis	Tornillo
43	00 30 100	1	Scheibe 6,4 mm	Washer	Rondelle	Arandela
44	00 94 141	2	Gummimetall 25x20 M6x12 mm ->)	Rubber metal ->)	Métal de gomme ->)	Metal de goma ->)
45	00 18 346	4	Zylinderschraube M6x16 mm	F.H. screw	Vis	Tornillo
46	00 72 120	1	Scheibe 10,2x20x1,1 mm	Washer	Rondelle	Arandela



Bild-Nr. Pos.-No. No.Pos. Pos.-No.	Bestell-Nr. Order-No. No. de Cde Ref.-Nr.	Menge Quantity Nombres Cantidad	<b>Luftfilter, Vergaser, Auspuff</b>	<b>Air filter, carburetor, exhaust</b>	<b>Filtre à air, carbureteur, échappement</b>	<b>Filtro de aire, carburador, escape</b>
1	00 21 256	2	Vierkantmutter M5	Nut	Ecrou	Tuerca
2	25 00 133	1	Auspuff	Exhaust	Echappement	Escape
3	20 61 441	1	Auspuffdichtung	Exhaust gasket	Joint d'échappement	Junta escape
4	00 72 144	6	Sicherungsscheibe 5 mm	Safety washer	Rondelle de sécurité	Arandela seguridad
5	00 18 378	1	Zylinderschraube M5x55 mm	F.H. screw	Vis	Tornillo
6	00 18 397	2	Zylinderschraube M5x65 mm	F.H. screw	Vis	Tornillo
7	20 61 155	1	Dichtung Ansaugstutzen	Manifold gasket	Joint de bride	Junta de brida
8	20 74 166	1	Vergaserflansch	Socket	Bride d'aspiration	Brida
9	00 18 326	6	Zylinderschraube M4x16 mm	F.H. screw	Vis	Tornillo
10	20 74 601 25	1	Abdichtplatte	Sealing plate	Plaque d'étanchéité	Chapa de junta
11	20 61 307	1	Vergaserdichtung	Carburetor gasket	Joint de carburateur	Junta carburador
12	20 61 306	1	Vergaserdichtung	Carburetor gasket	Joint de carburateur	Junta carburador
13	20 74 314 25	1	Vergaserabstandsplatte	Carburetor plate	Plaque de carburateur	Chapa de carburador
14	23 00 160	1	Vergaser WT 688 D-Cut	Carburetor	Carburateur	Carburador
15	25 00 157	1	Filtergehäuse enth. (-> 15 - 24	Filter housing incl. (-> 15 - 24	Carter filtre y inclus (-> 15 - 24	Carter de filtro incl. (-> 15 - 24
17	20 74 966 25	1	Chokeknopf	Knob	Bouton	Boton
23	27 00 322	1	Primer Pumpe	Primer	Pompe d'amorçage	Cabador
24	00 64 407	150 mm	Schlauch 2x1,5 mm ->)	Hose ->)	Tuyau ->)	Tubo ->)
27	00 18 429	2	Linsenschraube 5x50 mm	Screw	Vis	Tornillo
28	20 48 154	1	Luftfilter	Air filter	Filtre à air	Filtro de aire
29	20 74 682 25	1	Verschlussbolzen	Bolt	Axe de retenue	Perno
30	20 74 156 25	1	Luftfiltergehäuse Oberteil	Filter lid	Chapeau filtre	Tapa de filtro
31	00 28 149	1	Blechmutter 4,8 mm	Nut	Ecrou	Tuerca
32	20 73 161 25	1	Auspuffdeckel	Exhaust cover	Couvercle	Tapa de escape
33	00 18 335	1	Zylinderschraube M5x12 mm	F.H. screw	Vis	Tornillo
34	00 18 274	1	Linsenschraube 5x16 mm	Screw	Vis	Tornillo
35	20 74 905 25	1	Haltering	Ring	Bague de retient	Anillo
36	28 00 142	1	Bowdenzug Gas	Throttle cable	Câble des gaz	Cable bowden

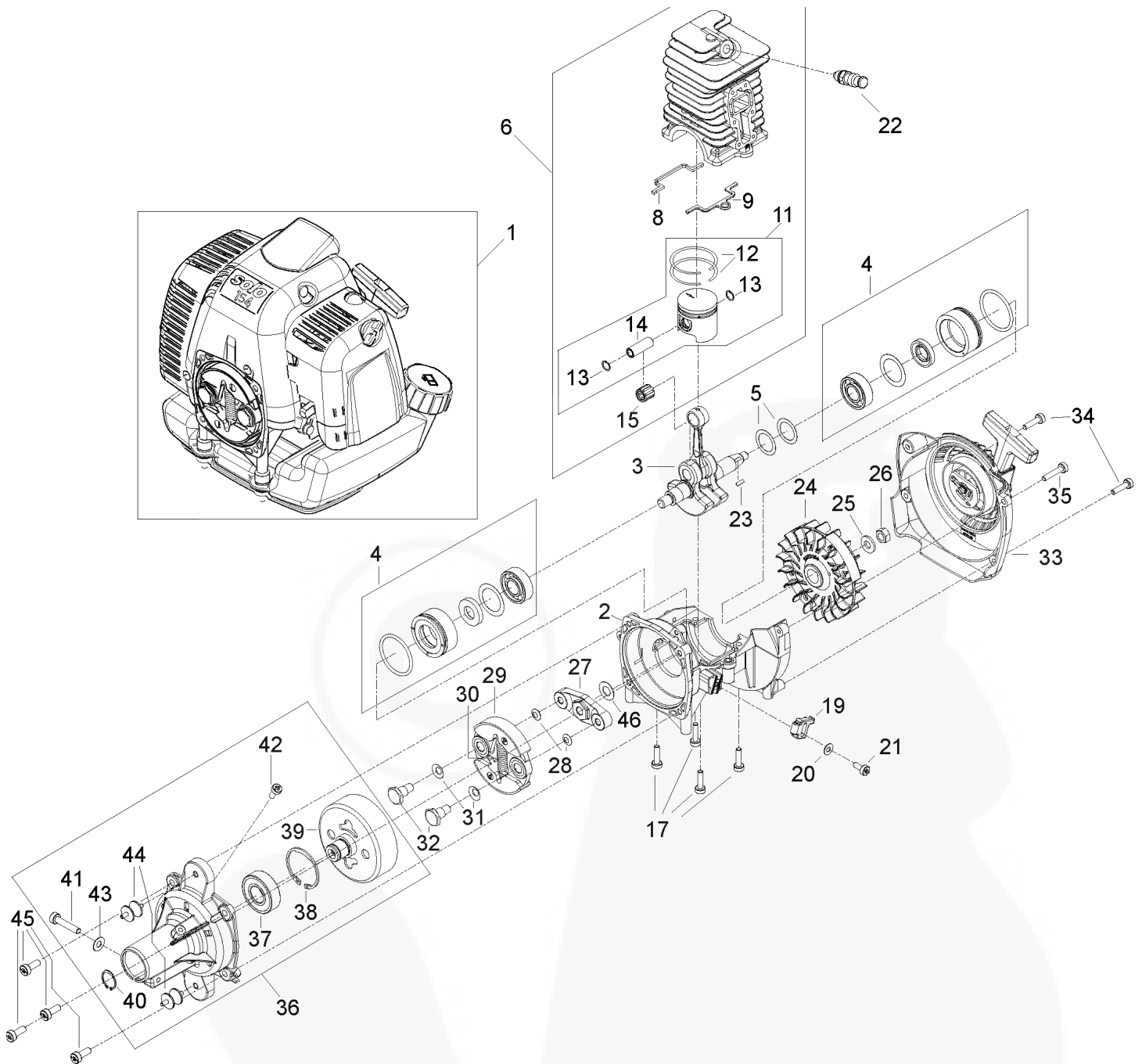

Bild-Nr. Pos.-No. No.Pos. Pos.-No.	Bestell-Nr. Order-No. No. de Cde Ref.-Nr.	Menge Quantity Nombres Cantidad	Zündung, Motor- Abdeckhaube	Ignition, cover	Allumage, capot	Encendido, cubierta
1	23 00 730	1	Zündkerze WSR6F 200	Spark plug	Bougie	Bujia
2	23 00 216	1	Zündmodul IIDA CDI enth. (-> 2 - 4	Ignition coil incl. (-> 2 - 4	Volant électronique y inclus (-> 2 - 4	Bobina incl. (-> 2 - 4
3	00 73 360	1	Kontaktfeder	Contact spring	Ressort de contact	Resorte
4	00 84 621	1	Zündkerzenstecker (-)	Spark plug cover (-)	Capuchon de bougie (-)	Tapa de bujia (-)
5	00 72 148	2	Sicherungsscheibe 4 mm	Safety washer	Rondelle de sécurité	Arandela seguridad
6	00 30 101	2	Scheibe 4,3 mm	Washer	Rondelle	Arandela
7	00 18 327	2	Zylinderschraube M4x20 mm	F.H. screw	Vis	Tornillo
8	00 84 155	1	Kabel Masse/Kurzschluss., Motorseite	Ground cable	Câble de masse	Cable de masa
9	00 66 455	1	Kabelband 98x2,5 mm	Cable band	Frein de câble	Cinta
10	20 73 155 25	1	Motor-Abdeckhaube	cover	capot	cubierta
11	20 74 237 25	1	Zündkerzenabdeckung	Spark plug cover	Capuchon de bougie	Tapa de bujia
12	00 68 145	1	Selbstklebeschild SOLO 154	Decal	Autocollant	Adhesivo
13	00 18 335	1	Zylinderschraube M5x12 mm	F.H. screw	Vis	Tornillo



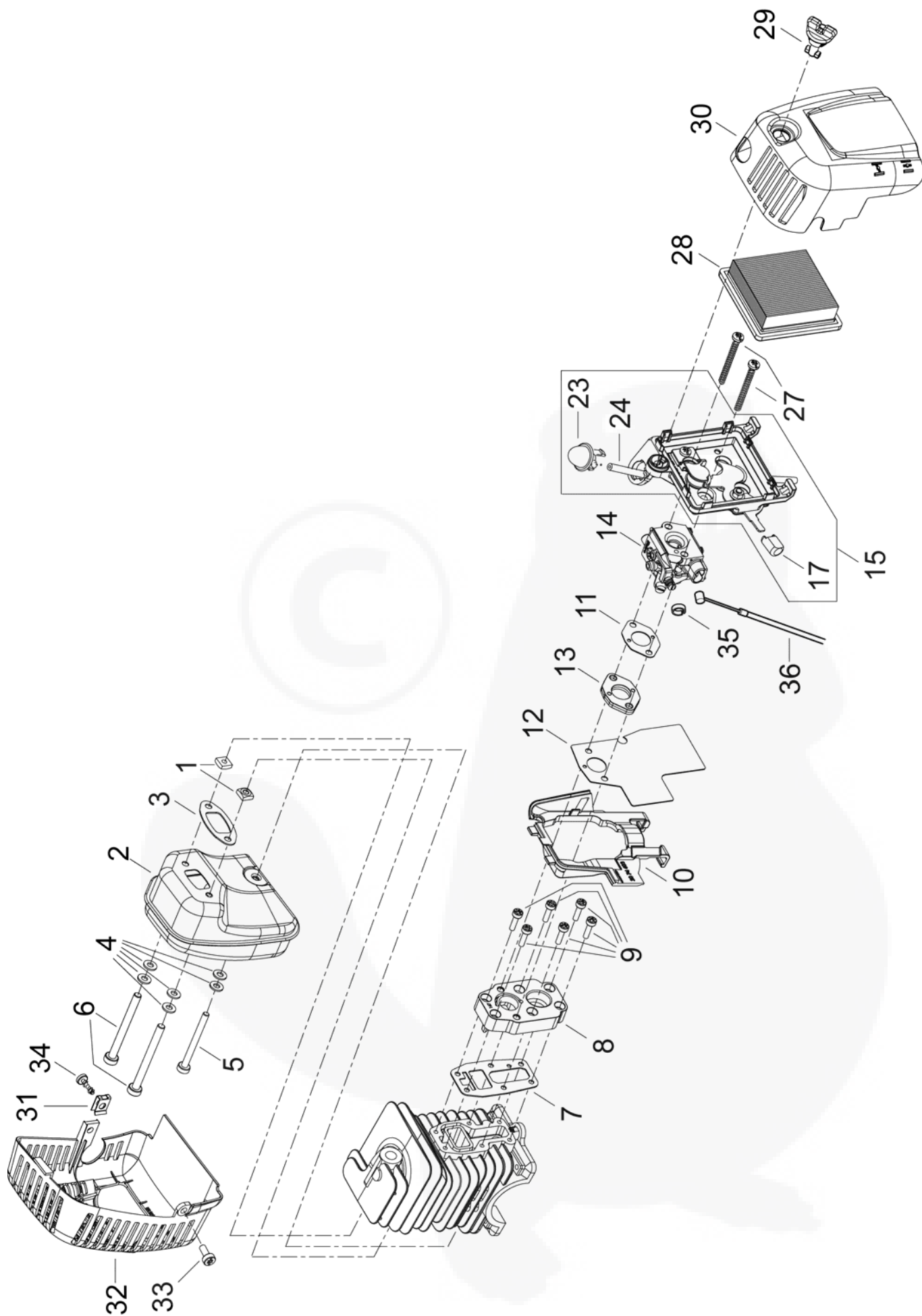

Bild-Nr. Pos.-No. No.Pos. Pos.-No.	Bestell-Nr. Order-No. No. de Cde Ref.-Nr.	Menge Quantity Nombres Cantidad	Benzintank	Fuel tank	Réservoir à essence	Deposito
1	00 15 193	4	Stiftschraube M5x35 mm	Stud screw	Goujon	Tornillo
2	20 31 154	4	ALU Distanzhülse	Distance sleeve	Entretoise	Casquillo
3	27 00 154	1	Benzintank enth. (-> 3 - 12)	Fuel tank incl. (-> 3 - 12)	Réservoir à essence y inclus (-> 3 - 12)	Deposito incl. (-> 3 - 12)
4	00 64 434	1	Schlauch 3x1,5x115 mm Entlüftung	Ventilation hose	Tuyau d'aération	Tube
5	27 00 430	1	Belüftungsstutzen	Ventilation socket	Manchon d'aération	Munon
6	60 63 349	1	Schlauch 3x210 mm Kraftstoff	Fuel hose	Tuyau	Tube
7	27 00 133	1	Filter Benzinsucher	Fuel pick-up	Crépine d'essence	Filtro
8	00 94 197	4	Dämpfungsgummi	AV element	Amortisseur	Elemento AV
9	00 64 450	1	Schlauch 3x1,5x130 mm Benzinrücklauf	Hose	Tuyau	Tube
10	00 66 455	1	Kabelband 98x2,5 mm	Cable band	Frein de câble	Cinta
11	27 00 187 25	1	Tankverschluss enth. (-> 11, 12)	Tank lid incl. (-> 11, 12)	Bouchon de réservoir y inclus (-> 11, 12)	Cierre de deposito incl. (-> 11, 12)
12	00 61 330	1	Dichtung 30,5x40,8x2 mm (->)	Gasket (->)	Joint (->)	Junta (->)
13	20 73 170 25	1	Tankschutz	Tank protection	Protection de reservoir	Proteccion del deposito
14	00 30 102	4	Scheibe 5,3 mm	Washer	Rondelle	Arandela
15	00 72 144	4	Sicherungsscheibe 5 mm	Safety washer	Rondelle de sécurité	Arandela seguridad
16	00 28 137	4	Sechskantmutter M5	Hex. nut	Ecrou	Tuerca

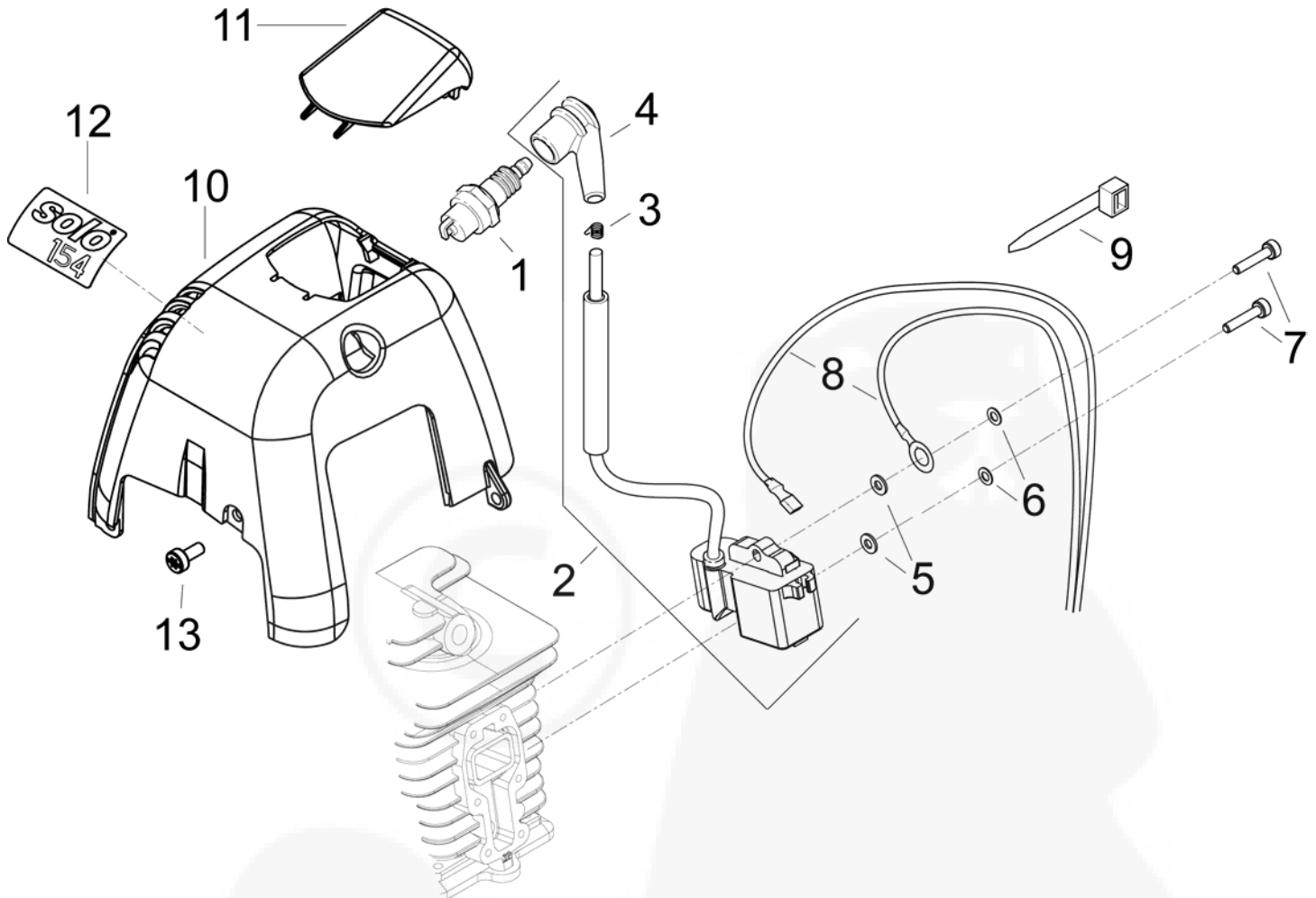

Bild-Nr. Pos.-No. No.Pos. Pos.-No.	Bestell-Nr. Order-No. No. de Cde Ref.-Nr.	Menge Quantity Nombres Cantidad	Starter	Starter	Lanceur	Arranque
1	26 00132	1	Starter enth. (-> 1 - 16)	Starter incl. (-> 1 - 16)	Lanceur y inclus (-> 1 - 16)	Arranque incl. (-> 1 - 16)
2	21 00 128	1	Startergehäuse	Starter housing	Carter lanceur	Caja de arranque
3	26 00 284	1	Federkassette	Spring cassette	Cassette de ressort	Cassette
4	20 74 915 25	1	Seilrolle	Rope pulley	Poulie de câble	Roldana
5	20 74 343	1	Starterklinke	Pawl	Cliquet de lanceur	Trinquete
6	00 31 611	1	Scheibe 4,3x14,3x1 mm	Washer	Rondelle	Rondelle
7	20 31 965	1	Distanzstück	Spacer	Pièce d'écartement	Espaciador
8	20 74 977 25	1	Kulisse	Template	Coulisse	Colisa
9	00 73 365	1	Federstecker	Pin	Goupille beta	Clavija
10	00 34 152	1	Sicherungsscheibe 4 mm	Safety washer	Rondelle de sécurité	Arandela seguridad
11	00 10 519	1	Zylinderschraube 3,5x22 mm	F.H. screw	Vis	Tornillo
12	20 74 403 25	1	Startergriff	Starter grip	Poignée lanceur	Empunadura
13	00 72 148	1	Sicherungsscheibe 4 mm	Safety washer	Rondelle de sécurité	Arandela seguridad
14	00 69 890	1	SKS SOLO	Decal	Autocollant Solo	Adhesivo
15	00 63 195 25	1	Starterseil 3x1050 gewachst	Starter rope	Câble lanceur	Cuerda de arranque
16	00 30 101	1	Scheibe 4,3 mm (-)	Washer (-)	Rondelle (-)	Arandela (-)
17	00 18 337	2	Zylinderschraube M5x20 mm	F.H. screw	Vis	Tornillo
18	00 18 338	1	Zylinderschraube M5x25 mm	F.H. screw	Vis	Tornillo



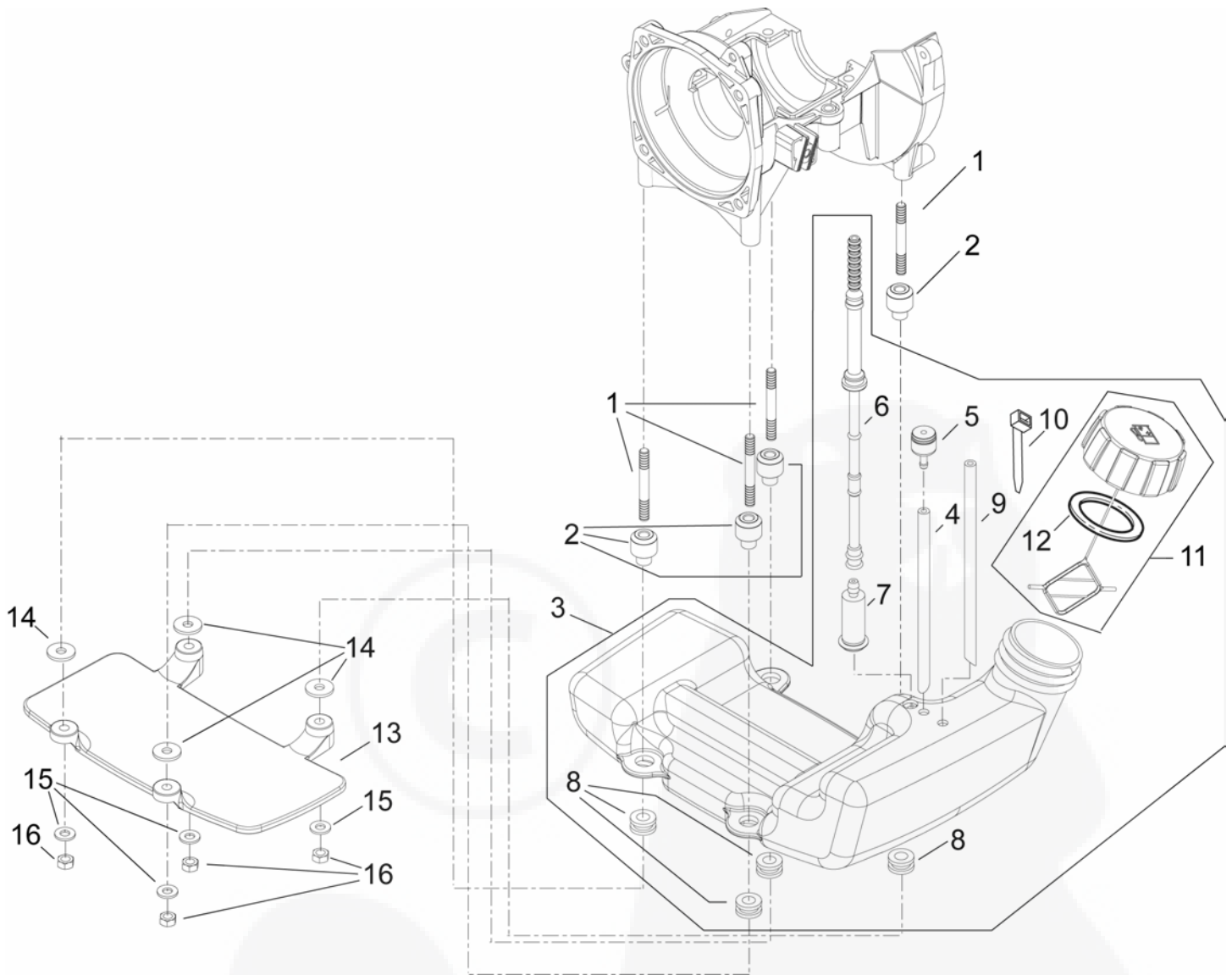

Bild-Nr. Pos.-No. No.Pos. Pos.-No.	Bestell-Nr. Order-No. No. de Cde Ref.-Nr.	Menge Quantity Nombres Cantidad	Schaftrohr, Alu-Profil	Shaft tube, profile	Tube, p rofil	Tubo, p erfil
1	20 00 355	1	Motor 54cm³	Engine	Moteur	Motor
2	00 94 141	2	Gummimetall 25x20 M6x12 mm	Rubber metal	Métal de gomme	Metal de goma
3	00 72 102	2	Scheibe 6,2x18x0,8 mm	Washer	Rondelle	Arandela
4	00 20 122	2	6KT Mutter M6 selbstsichernd	Hex. nut	Ecrou	Tuerca
5	63 00 156	1	Aluprofil vollst. enth. (-> 5 - 19)	Profile incl. (-> 5 - 19)	Profil y inclus (-> 5 - 19)	Perfil incl. (-> 5 - 19)
6	20 73 154	1	Griffgehäuse-Bike-Anschluß	Grip housing	Carter poignée	Carter
7	20 16 154	1	Strangpressprofil	Profile	Profil	Perfil
8	00 18 175	6	Linsenschraube DG 50x20 mm	Screw	Vis	Tornillo
9	20 74 165	1	Gurtaufhaengung	Strap holder	Porte-bretelle	Hebilla para correa
10	20 73 160	1	Klemmhalter	Support	Support	Soporte
11	20 73 165	1	Klemmhalterdeckel	Cover	Couvercle	Tapa
12	00 18 274	4	Linsenschraube 5x16 mm	Screw	Vis	Tornillo
13	00 94 141	2	Gummimetall 25x20 M6x12 mm	Rubber metal	Métal de gomme	Metal de goma
14	00 20 122	2	6KT Mutter M6 selbstsichernd	Hex. nut	Ecrou	Tuerca
15	00 72 102	2	Scheibe 6,2x18x0,8 mm	Washer	Rondelle	Arandela
16	35 00 111	1	Schnellverschluß M8x60 mm	Lock	Fermeture	Cierre
17	60 63 346	1	Gummielment	Rubber element	Element de gomme	Elemento de goma
18	00 30 115	1	Scheibe 4,3x12 mm	Washer	Rondelle	Arandela
19	00 18 354	1	Linsenschraube 4 x 12-mm (-)	Screw (-)	Vis (-)	Tornillo (-)
20	20 74 180	1	Bikeanschlußdeckel	Cover	Couvercle	Tapa
21	20 73 164	1	Klemmstück	Clamping piece	Pièce de serrage	Fijacion
22	00 20 122	2	6KT Mutter M6 selbstsichernd	Hex. nut	Ecrou	Tuerca
23	00 72 102	2	Scheibe 6,2x18x0,8 mm	Washer	Rondelle	Arandela
24	60 35 390	1	Antriebswelle hohl 8x4,5x1553 mm	Drive shaft	Arbre	Arbol
25	63 00 263	1	Schaftrohr 30x2x1500 mm Alu	Shaft tube	Tube	Tubo

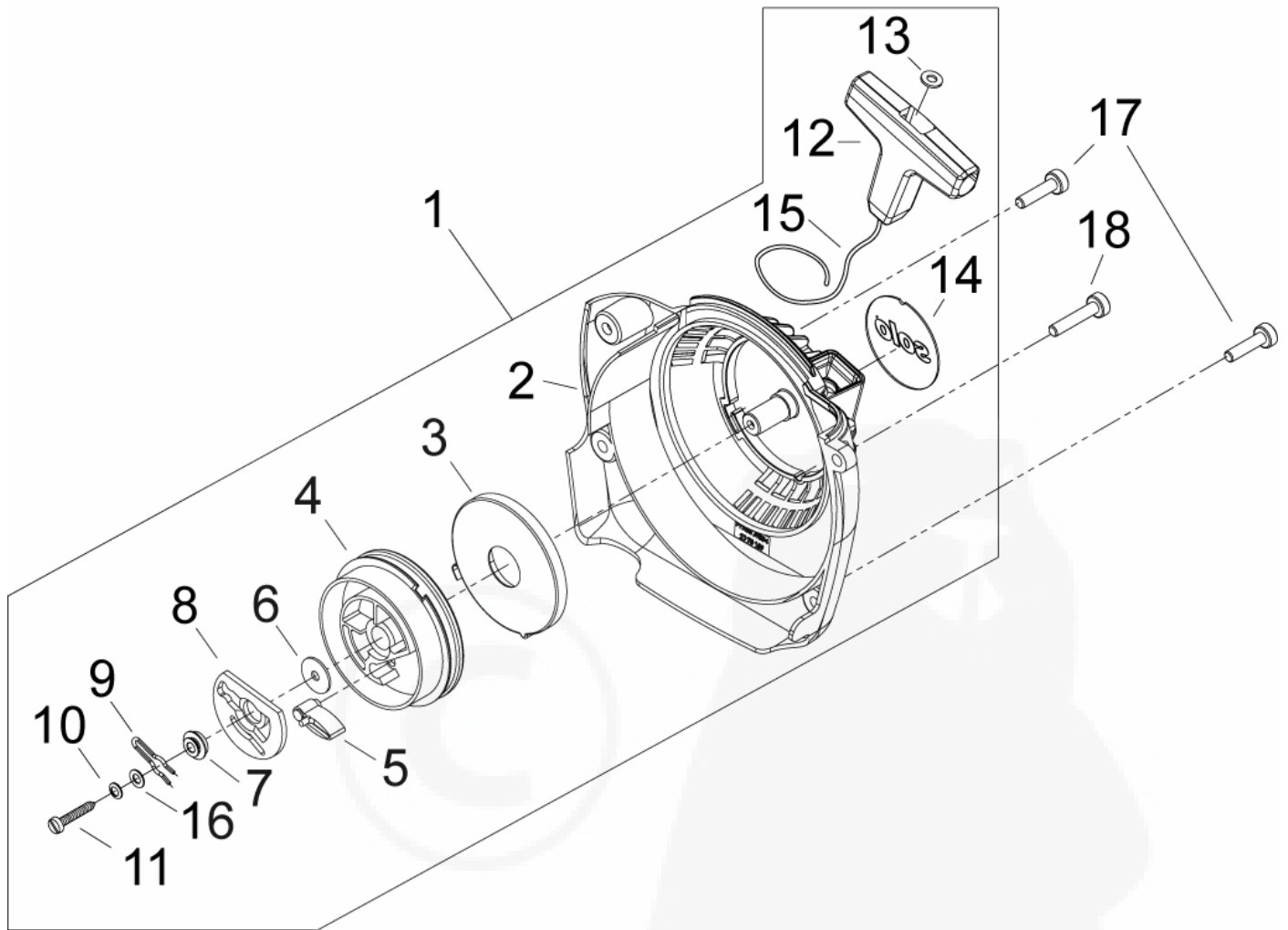

Bild-Nr. Pos.-No. No.Pos. Pos.-No.	Bestell-Nr. Order-No. No. de Cde Ref.-Nr.	Menge Quantity Nombres Cantidad	Bikegriff, Gasbetätigung	Handle, throttle control	Poignée, levier de réglage	Tubo, acelerador de gas
1	68 00 400	1	Gasgriff, kompl. enth. (-> 1 - 14)	Throttle grip, cpl. incl. (-> 1 - 14)	Poignée acc., cpl. y inclus (-> 1 - 14)	Acelerador cpl. incl. (-> 1 - 14)
2	60 73 569	1	Griffhälfte außen rechts	Grip half	Poignée extérieure	Cascara
3	60 73 570	1	Griffhälfte innen rechts	Grip half	Poignée extérieure	Cascara
4	00 73 388	1	Kontaktfeder	Contact spring	Ressort de contact	Resorte
5	00 73 389	1	Kontaktfeder	Contact spring	Ressort de contact	Resorte
6	60 73 572 25	1	Schieber	Slide	Tiroir	Valvula
7	00 73 387	1	Schenkelfeder 1,3x6, Schieber	Spring	Ressort d'interrupteur	Muelle
8	60 73 573 25	1	Gashebel	Throttle lever	Levier de gaz	Palanca de gas
9	00 35 158	1	Sicherungsscheibe 4,5x0,3 mm	Safety washer	Rondelle de sécurité	Arandela seguridad
10	00 73 386	1	Schenkelfeder 1x8, Gashebel	Spring	Ressort d'interrupteur	Muelle
11	60 73 571 25	1	Sicherungshebel	Safety lever	Levier de sécurité	Palanca
12	00 18 356	3	Linsenschraube 4x20 mm	Screw	Vis	Tornillo
13	00 18 364	1	Zylinderschraube M5x32 mm	F.H. screw	Vis	Tornillo
14	00 20 131	1	Sechskantmutter M5 (-)	Nut (-)	Écrou (-)	Tuerca (-)
15	00 64 415 27	0,77m	Schlauch 8,5 mm	Hose	Tuyau	Tubo
16	00 84 154	1	Kabel Masse/Kurzschluss	Ground cable	Câble masse	Cable de masa
17	28 00 142	1	Bowdenzug Gas	Throttle cable	Câble des gaz	Cable bowden
18	50 74 100	1	Bowdenzughalter, 22 mm	Bowden cable support	Collier de serrage	Soporte de cable bowden
19	60 35 370 25	1	Bike-Griffrohr 22x1,5 mm	Handlebar	Etrier de maintien	Tubo de palanca
20	60 73 568 25	1	Griffhälfte innen links	Grip half	Poignée extérieure	Cascara
21	60 73 567 25	1	Griffhälfte außen links	Grip half	Poignée extérieure	Cascara
22	00 18 356	2	Linsenschraube 4x20 mm	Screw	Vis	Tornillo
23	00 18 364	1	Zylinderschraube M5x32 mm	F.H. screw	Vis	Tornillo
24	00 20 131	1	Sechskantmutter M5	Nut	Écrou	Tuerca
25	35 00 111	1	Schnellverschluss	Lock	Fermeture	Cierre
26	60 12 836 25	1	Klemmschale unten	Handle bar clamp cup	Plaque de serrage guidon	Cascara
27	60 12 837 25	1	Klemmschale oben	Handle bar clamp cup	Plaque de serrage guidon	Cascara
28	00 18 337	2	Zylinderschraube M5x20 mm	F.H. screw	Vis	Tornillo

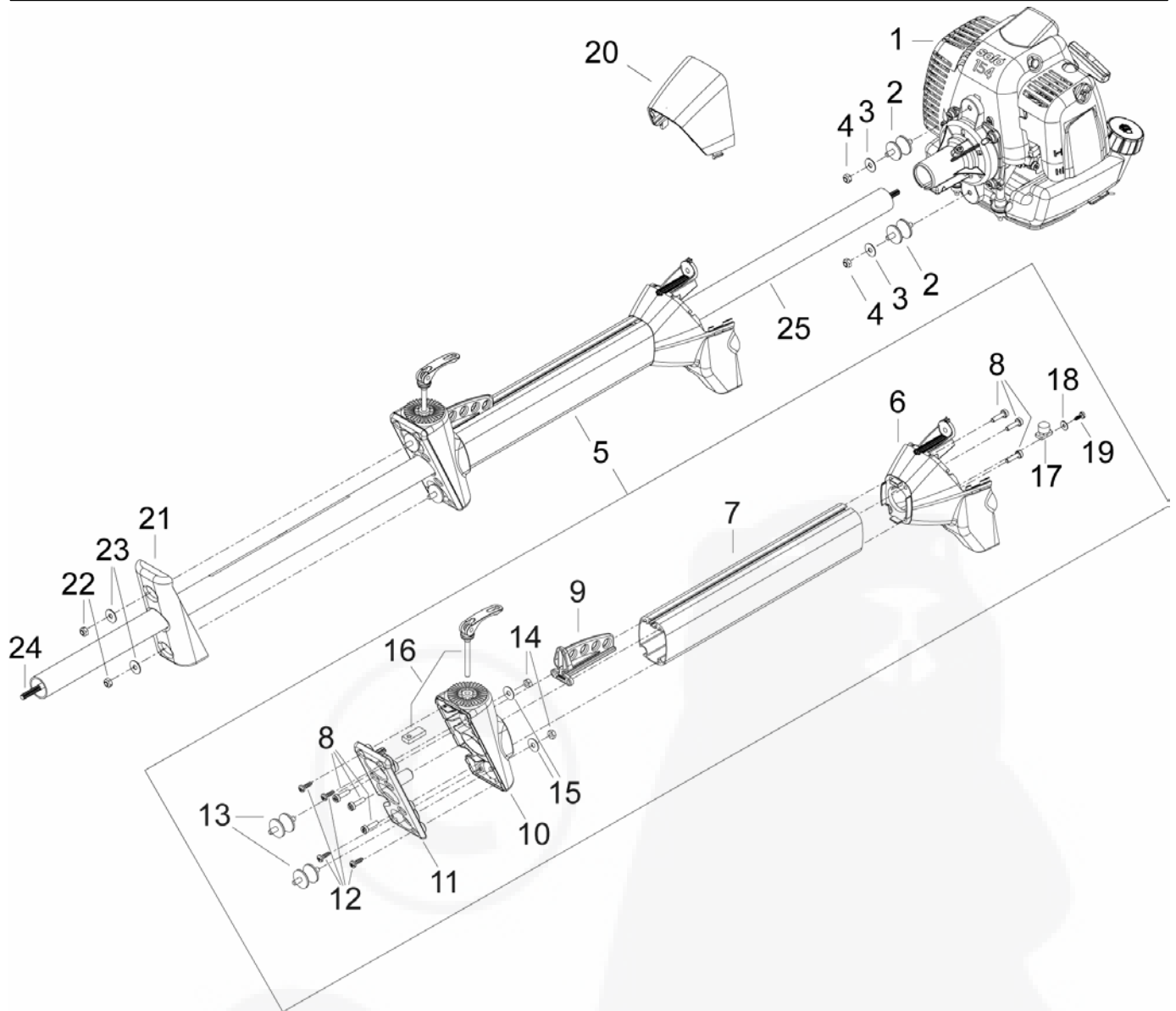

\* nicht bei Fadenkopf/  
not with nylon head/  
ne pas avec tête fils/  
no para cabezal de hilo

\*\* nur bei Fadenkopf/  
only with nylon head/  
seulement pour tête fils/  
solamente para cabezal de hilo

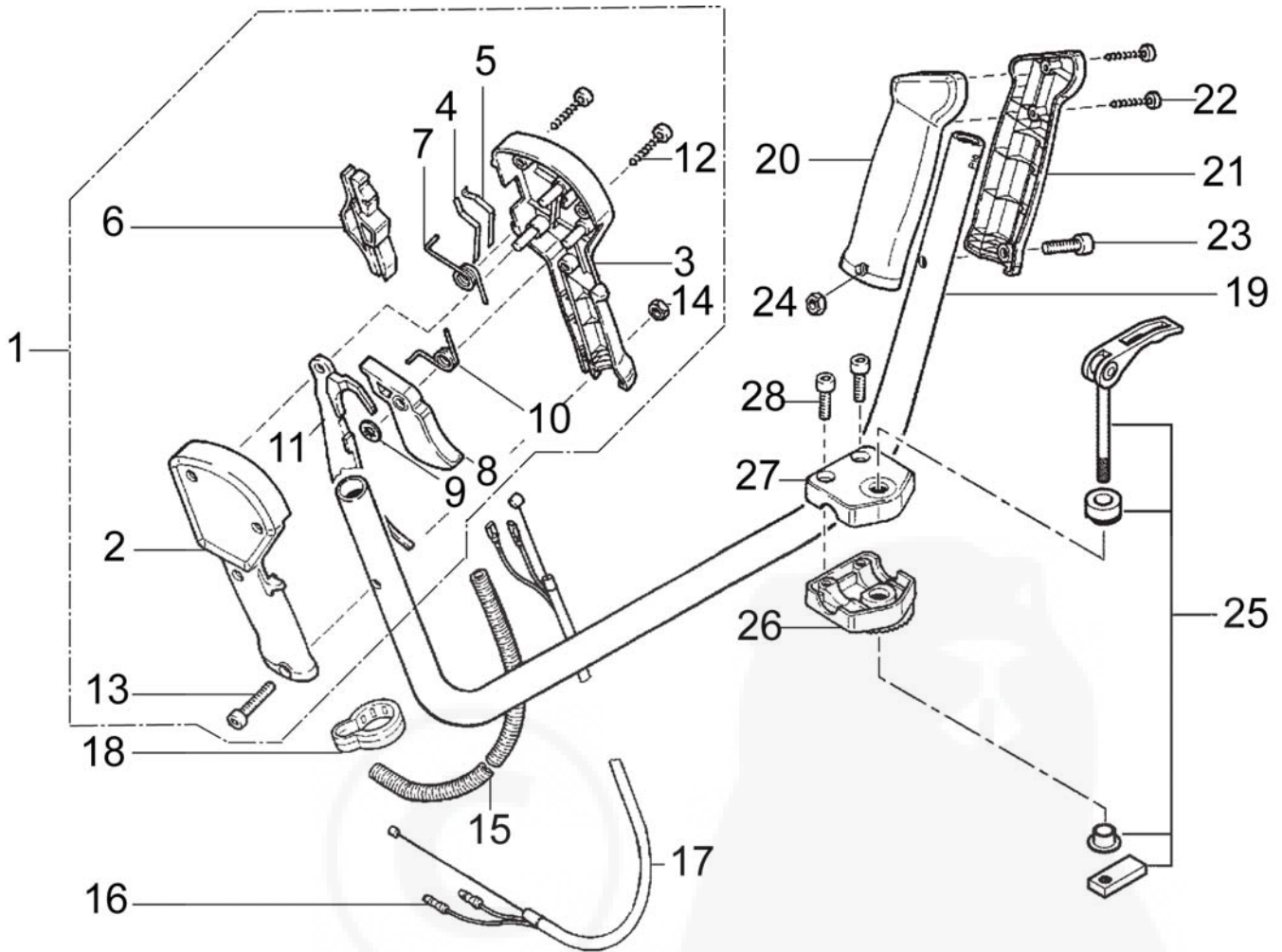
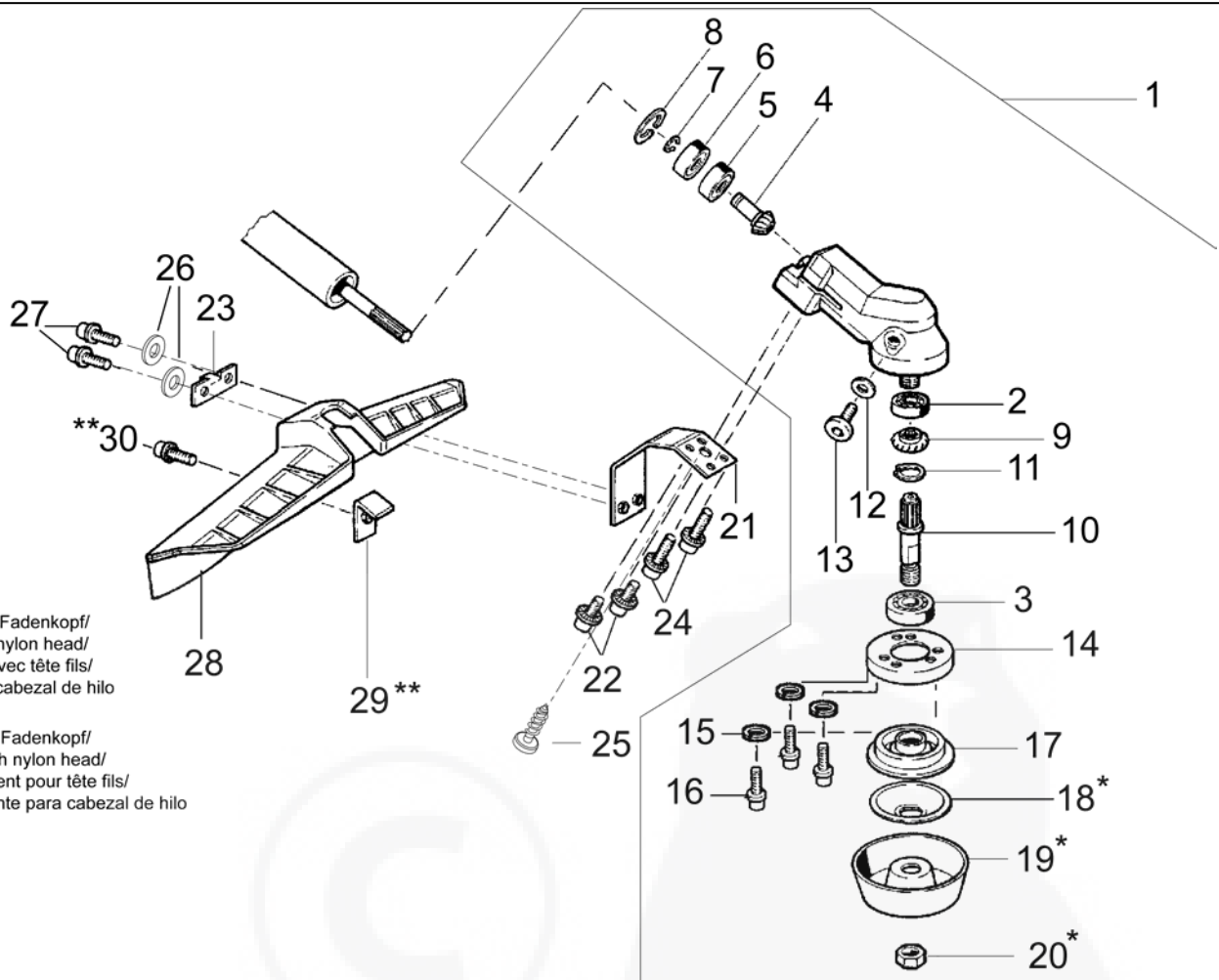
Bild-Nr. Pos.-No. No.Pos. Pos.-No.	Bestell-Nr. Order-No. No. de Cde Ref.-Nr.	Menge Quantity Nombres Cantidad	Getriebe, Schutz	Gear, protection	Engrenage, protection	Engranaje, proteccion
1	30 00 155	1	Getriebe SOLO, kompl. enth. (-> 1 - 20)	Gear SOLO, compl. incl. (-> 1 - 20)	Renvoi d'angle SOLO, compl. y inclus (-> 1-20)	Engranaje SOLO, compl. incl. (-> 1 - 20)
2	00 50 199	1	Kugellager 9x26x8 mm	Ball bearing	Roulement à billes	Cojinete de bolas
3	00 50 198	1	Kugellager 15x35x11 mm	Ball bearing	Roulement à billes	Cojinete de bolas
4	30 38 408	1	Kegelrad, 17 Zähne	Drive wheel, 17 teeth	Roue dentée, 17 dents	Rueda de mandos, 17 dientes
5	00 50 174	1	Kugellager 12x28x8 mm	Ball bearing	Roulement à billes	Cojinete de bolas
6	00 50 197	1	Kugellager 12x28x8 mm	Ball bearing	Roulement à billes	Cojinete de bolas
7	00 55 134	1	Sicherungsring 12x1 mm	Circlip	Circlip	Anillo de seguridad
8	00 55 166	1	Sicherungsring 28x1,2 mm	Circlip	Circlip	Anillo de seguridad
9	30 38 426	1	Kegelrad, 21 Zähne	Drive wheel, 21 teeth	Roue dentée, 21 dents	Rueda de mandos, 21 dientes
10	30 31 305	1	Getriebewelle 15/M12x1,5x86,5	Gear shaft	Arbre de transmission	Arbol de engranaje
11	00 55 273	1	Sicherungsring 12x1 mm	Circlip	Circlip	Anillo de seguridad
12	00 61 210	1	Dichtring 10x13,5x1 mm	Gasket	Joint	Junta
13	00 18 415	1	Verschlußschraube M10x1 mm	Locking screw	Vis	Tornillo
14	30 43 415	1	Wickelschutz	Anti-clogging device	Protecteur d'enroulement	Proteccion de arrollamiento
15	00 72 175	3	Tellerfeder 5,2x15x0,7 mm	Spring washer	Rondelle plat	Resorte
16	00 18 336	3	Zylinderschraube M5x16 mm	F.H. screw	Vis	Tornillo
17	30 31 968 25	1	Druckstück Ø 20 mm	Pressure plate	Pièce de pression	Pieza de presion
18	30 43 441	1	Druckscheibe 12,15/40x3,5 mm	Washer	Rondelle de pression	Arandela
19	30 43 427	1	Lauffeller	Nut protector	Disque de glissement	Plato de motriz
20	00 21 240	1	Sechskantmutter M12 (-)	Nut (-)	Écrou (-)	Tuerca (-)
21	63 00 215	1	Haltewinkel	Bracket	Équerre support	Soporte
22	00 18 336	2	Zylinderschraube M5x16 mm	F.H. screw	Vis	Tornillo
23	60 43 418	1	Halteblech	Plate	Tôle de support	Chapa
24	00 18 340	2	Zylinderschraube M5x40 mm	F.H. screw	Vis	Tornillo
25	00 18 323	1	Zylinderschraube M5x12,5 mm	F.H. screw	Vis	Tornillo
26	00 72 144	2	Sicherungsscheibe 5 mm	Safety washer	Rondelle de sécurité	Arandela seguridad
27	00 18 336	2	Zylinderschraube M5x16 mm	F.H. screw	Vis	Tornillo
28	60 73 574	1	Schutz, rot	Protection, red	Protection, rouge	Proteccion, rojo
29	69 00 688	1	Fadenbegrenzungsmesser	Knife	Couteau	Cuchilla
30	00 18 335	1	Zylinderschraube M5x12 mm	F.H. screw	Vis	Tornillo



Bild-Nr. Pos.-No. Pos.-No. Pos.-No.	Bestell-Nr. Order-No. No. de Cde Ref.-Nr.	Menge Quantity Nombres Cantidad	Werkzeug	Tools	Outilsage	Herramientas
1	63 00 300	1	Doppel-Schultergurt	Double shoulder strap	Bretelles	Doble correa bandolera
2	00 80 514 25	1	Montagestift 5 mm	Locking pin	Goupille de montage	Perno
3	00 80 509	1	Kombischlüssel SW19/T25	Combi wrench	Clef combi	Llave combi
4	30 43 415	1	Wickelschutz	Anti-clogging device	Protecteur d'enroulement	Proteccion de arrollamiento
5	00 72 175	3	Tellerfeder 5,2x15x0,7 mm	Spring washer	Rondelle plat	Resorte
6	00 18 336	3	Zylinderschraube M5x16 mm	F.H. screw	Vis	Tornillo
7	30 31 968 25	1	Druckstück Ø 20 mm	Pressure plate	Pièce de pression	Pieza de presion
8	69 00 943	1	Dickichtmesser 3 Zähne Ø 250 mm	3-tooth brush blade shaft	Lame à broussailles 3 dents	3 cuchilas en forma de z para matorral
9	30 43 441	1	Druckscheibe 12,15/40x3,5 mm	Washer	Rondelle de pression	Arandela
10	30 43 427	1	Laufsteller	Nut protector	Disque de glissement	Plato de motriz
11	00 21 240	1	Sechskantmutter M12x1,5	Nut	Écrou	Tuerca

			Zubehör	Accessories	Accesorios	Accesorios
(12)	69 00 653	1	Fadenkopf, halbautom.	Semi-autom. Nylon head	Tête fils semi-autom.	Cabezal de hilo semi- autom.
(13)	69 00 974	15m	Ersatzfaden für Fadenkopf Ø 3 mm	Replacement line	Recharge fils	Hilo de recambio
(14)	69 00 945	1	Mähzscheibe, Rototrim	Rototrim mowing blade	Lame, Rototrim	Disco de corte, Rototrim
(15)	69 00 695	1	Kreissägeblatt, kompl. mit Anschlag SKN	Saw blade scarlet, compl.	Lame scie, compl.	Hojo de sierra, compl.
(16)	69 00 948	1	Grasschneideblatt, 4 Zähne Ø 230 mm	Grass cutt. Blade 4-t	Lame herbe, 4-dents	Hoja de corte, 4 dientes

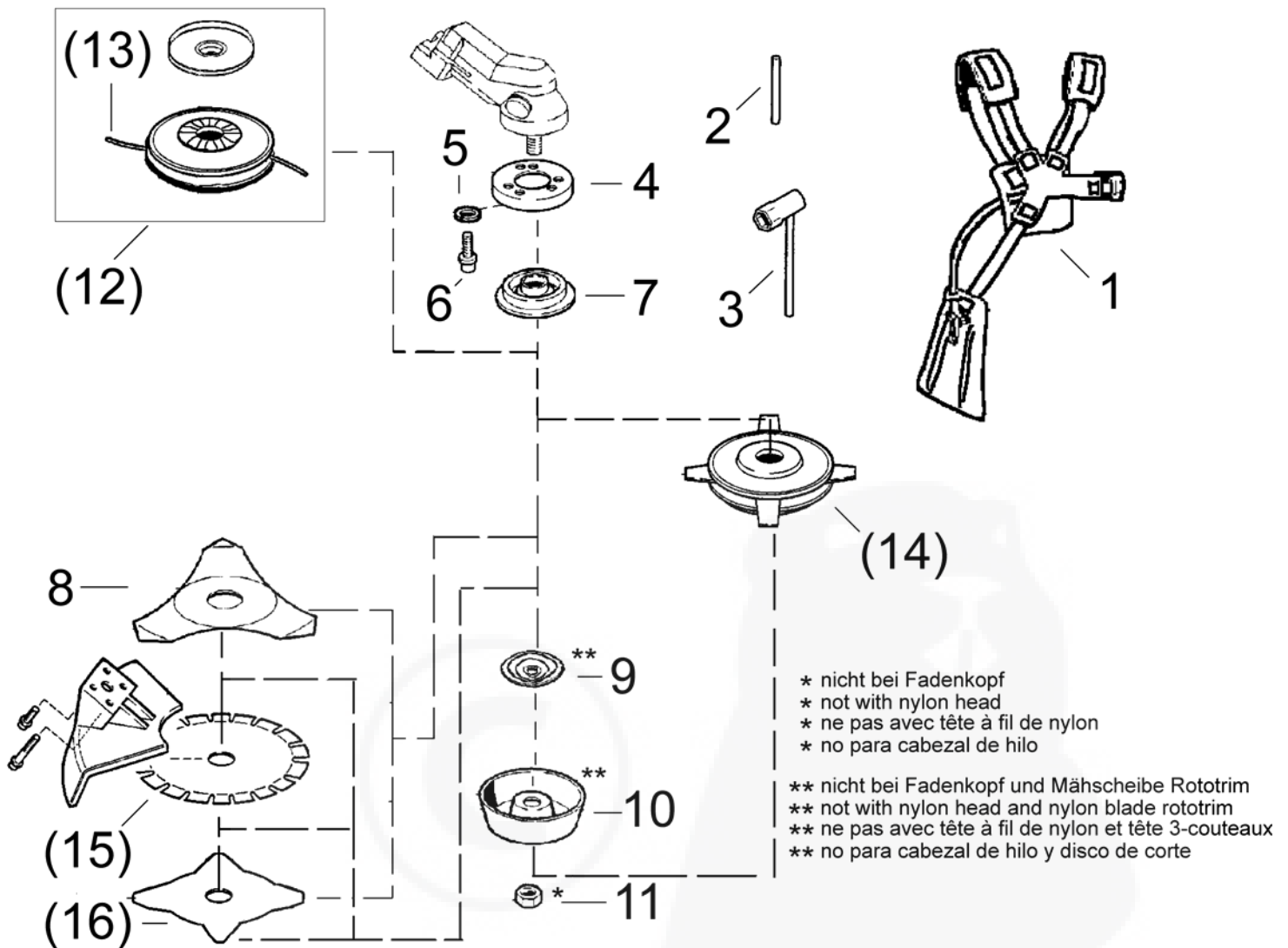

Bestell-Nr. Order-No. No. de Cde Ref.-Nr.	Menge Quantity Nombres Cantidad	Zubehör o. Abb.	Accessories	Accesories	Accesorios
69 00 160	1	2 Faden Schneidekopf „Jet-Fit“	Cutter head "Jet-Fit"	Tête faucheuse "Jet-Fit"	Cabeza de corte "Jet-Fit"
69 00 162	1	4 Faden Schneidekopf „Jet-Fit“	Cutter head "Jet-Fit"	Tête faucheuse "Jet-Fit"	Cabeza de corte "Jet-Fit"
69 00 166	50	Ersatzfaden „Jet-Fit“ 2,5 x 260 mm	Replacement line for "Jet-Fit" 2,5 x 260 mm	Fil de rechange "Jet Fit" 2,5 x 260 mm	Hilo de recambio "Jet Fit" 2,5 x 260 mm
69 00 168	25	Ersatzfaden „Jet-Fit“ 3,5 x 260 mm	Replacement line for "Jet-Fit" 3,5 x 260 mm	Fil de rechange "Jet Fit" 3,5 x 260 mm	Hilo de recambio "Jet Fit" 3,5 x 260 mm
69 00 175	53 m	Ersatzfaden „Jet-Fit“ 2,5 mm	Replacement line for 2,5 mm	Fil de rechange "Jet Fit" 2,5 mm	Hilo de recambio "Jet Fit" 2,5 mm
69 00 176	27 m	Ersatzfaden „Jet-Fit“ 3,5 mm	Replacement line for "Jet-Fit" 3,5 mm	Fil de rechange "Jet Fit" 3,5 mm	Hilo de recambio "Jet Fit" 3,5 mm
00 83 103	100ml	Profi 2T-Motoröl	Special 2-stroke oil	Huile spéciale 2 temps	Aceite especial para motores de 2 tiempos
00 83 104	1l	Profi 2T-Motoröl	Special 2-stroke oil	Huile spéciale 2 temps	Aceite especial para motores de 2 tiempos
00 83 105	1l	Profi 2T-Motoröl in Dosierflasche	Special 2-stroke oil, bottle with metering indicator	Huile spéciale 2 temps, en flacon gradué	Aceite especial para motores de 2 tiempos, en botella plastica con escala dosificadora
27 00 278	1	Kraftstoff Mix-Behälter	Mixing can	Jerrycan	Tanque de mezclar
00 83 163	300 ml	Wartungs-/Pflege-Öl	Oil	Huile	Aceite
00 83 180	100 g	Spezial- Getriebefett	Grease	Graisse	Grasa
99 303 000 + Größe (2[s]-6[xxl])	1	Forst- und Landschafts-arbeitsjacke EN 340	Jacket	Veste forestiere	Chaqueta
99 020 95 + Größenindex	1	SOLO Outdoor Bundhose	Zip-off trousers	Pantalon de loisir	Pantalon
99 020 94 + Größenindex	1	SOLO Outdoor Latzhose	Flap trousers	Salopette de loisir	Pantalon con peto
99 305 00 + Größe (36 - 48)	1	Leder Forststiefel	Boots	Bottes forestieres	Zapatos
99 390 1001 (Uni-Größe)	1	Gesichts / Gehörschutzkombination	Ear & face protection	Protection ouie et visage	Protection de oido y faz
99 390 12 + Größenindex	1	Handschuhe SOLO Fit	Gloves SOLO Fit	Gants SOLO Fit	Guantes SOLO Fit

**D**

**Allgemeine Richtlinien für die Bestellung von Original SOLO Ersatzteilen:**

Voraussetzung für eine reibungslose Erledigung sind folgende Angaben:

1. Ersatzteil-Bestellnummer
2. Gewünschte Anzahl
3. Typenbezeichnung des Geräts

Diese Ersatzteilliste ist für die Lieferung und Ausstattung von SOLO Erzeugnissen unverbindlich. Im Interesse der technischen Weiterentwicklung bleiben Konstruktionsänderungen vorbehalten.

**GB**

**General Directions for Ordering Original SOLO Spare Parts:**

For correct and diligent processing of your order, please give the following information:

1. Spare Part number
2. Quantity
3. Model and serial number
4. Shipping instructions

Delivery is made in accordance with our general sales and delivery conditions. This spare parts list is non-committal for us with regard to delivery and layout of SOLO products. In favour of technical improvements, design modifications are subject to change without notice.

**F**

**Directives générales pour les commandes de pièces de rechange d'origine SOLO:**

Il est indispensable de préciser dans toutes les commandes de pièces:

1. le numéro de référence de la pièce
2. la quantité
3. le type de la machine
4. le mode d'expédition

Les livraisons sont effectuées dans le cadre de nos conditions générales de vente. Toutes modifications réservées.

**E**

**Directivas Generales de pedido de la firma SOLO:**

Por adelantado de un arreglo sin dificultades necesitamos siguientes indicaciones:

1. Número de repuesto
2. Numero de cantidad
3. Modelo y número de serial
4. Instrucción de Envío

Esta lista de repuestos no es obligatoria para los envíos y/o forma de equipo de los productos SOLO. En el interés del constante desarrollo debemos reservarnos el derecho de cambios.

Bestell-Nr. Order-No. No. de Cde Ref.-Nr.	Menge Quantity Nombres Cantidad	Seite Page Page Pagina
00 10 519	1	9
00 15 193	4	11
00 18 114	2	2
00 18 175	6	8
00 18 274	1	9
00 18 274	4	9
00 18 323	1	8
00 18 326	6	8
00 18 327	2	8
00 18 335	1	8
00 18 335	1	8
00 18 335	1	11
00 18 335	1	9
00 18 336	3	8
00 18 336	2	11
00 18 336	2	8
00 18 336	3	9
00 18 337	1	9
00 18 337	2	8
00 18 337	2	9
00 18 337	2	9
00 18 338	1	8
00 18 338	1	9
00 18 340	2	9
00 18 346	4	8
00 18 349	1	10
00 18 354	1	2
00 18 356	3	2
00 18 356	2	9
00 18 364	1	11
00 18 364	1	9
00 18 378	1	11
00 18 397	2	11
00 18 405	1	9
00 18 415	1	8
00 18 429	2	10
00 20 122	2	10
00 20 122	2	11
00 20 122	2	8
00 20 131	1	11
00 20 131	1	2
00 20 145	1	2
00 21 240	1	2
00 21 240	1	8
00 21 256	2	8
00 28 137	4	8
00 28 149	1	8
00 30 100	1	8
00 30 101	2	2
00 30 101	1	8
00 30 102	4	10
00 30 115	1	8
00 31 206	1	8
00 31 611	1	9

Bestell-Nr. Order-No. No. de Cde Ref.-Nr.	Menge Quantity Nombres Cantidad	Seite Page Page Pagina
00 34 152	1	10
00 35 158	1	8
00 50 174	1	8
00 50 197	1	9
00 50 198	1	8
00 50 199	1	2
00 50 250	1	9
00 52 255	1	10
00 55 105	1	11
00 55 113	1	2
00 55 134	1	9
00 55 166	1	2
00 55 267	1	11
00 55 273	1	10
00 61 210	1	9
00 61 330	1	11
00 63 195 25	1	8
00 64 407	150 mm	11
00 64 415 27	0,77m	10
00 64 434	1	8
00 64 450	1	9
00 66 455	1	8
00 66 455	1	9
00 68 145	1	2
00 69 890	1	8
00 71 154	1	9
00 72 102	2	11
00 72 102	2	11
00 72 102	2	9
00 72 120	1	8
00 72 140	1	2
00 72 144	6	2
00 72 144	4	9
00 72 144	2	2
00 72 145	1	9
00 72 148	2	8
00 72 148	1	2
00 72 149	2	11
00 72 174	2	8
00 72 175	3	8
00 72 175	3	10
00 73 360	1	10
00 73 365	1	11
00 73 386	1	9
00 73 387	1	8
00 73 388	1	9
00 73 389	1	8
00 75 101	1	8
00 80 509	1	11
00 80 514 25	1	2
00 84 154	1	9
00 84 155	1	8
00 84 621	1	9
00 94 141	2	2

Bestell-Nr. Order-No. No. de Cde Ref.-Nr.	Menge Quantity Nombres Cantidad	Seite Page Page Pagina
00 94 141	2	11
00 94 141	2	2
00 94 197	4	8
20 00 355	2	10
20 11 144	1	9
20 16 154	1	2
20 31 154	4	10
20 31 249 25	1	11
20 31 965	1	2
20 48 154	1	9
20 48 357	1	2
20 61 155	1	10
20 61 306	1	8
20 61 307	1	8
20 61 441	1	9
20 63 133	1	8
20 63 134	1	9
20 73 154	1	8
20 73 155 25	1	9
20 73 160	1	8
20 73 161 25	1	8
20 73 164	1	8
20 73 165	1	9
20 73 170 25	1	11
20 74 106 25	1	8
20 74 156 25	1	2
20 74 165	1	8
20 74 166	1	9
20 74 180	1	8
20 74 237 25	1	9
20 74 314 25	1	8
20 74 343	1	9
20 74 403 25	1	8
20 74 601 25	1	2
20 74 682 25	1	8
20 74 905 25	1	9
20 74 915 25	1	8
20 74 966 25	1	2
20 74 977 25	1	11
21 00 128	1	8
21 00 162	1	9
22 00 142	1	8
22 00 158	2	8
22 00 159	2	9
23 00 160	1	9
23 00 216	1	11
23 00 730	1	11
24 00 154	1	9
25 00 133	1	9
25 00 157	1	9
26 00 132	1	8
26 00 284	1	8
26 00 132	1	2
27 00 133	1	8

Bestell-Nr. Order-No. No. de Cde Ref.-Nr.	Menge Quantity Nombres Cantidad	Seite Page Page Pagina
27 00 154	1	9
27 00 187 25	1	2
27 00 322	1	11
27 00 430	1	2
28 00 142	1	2
28 00 142	1	8
28 00 570	1	8
30 00 155	1	8
30 16 154	1	11
30 31 305	1	11
30 31 968 25	1	8
30 31 968 25	1	8
30 38 408	1	8
30 38 426	1	11
30 43 415	1	2
30 43 415	1	11
30 43 427	1	9
30 43 427	1	8
30 43 441	1	9
30 43 441	1	8
33 00 143	1	2
35 00 111	1	10
35 00 111	1	11
35 00 130	1	10
35 00 136	1	11
50 74 100	1	2
60 12 836 25	1	11
60 12 837 25	1	10
60 35 370 25	1	8
60 35 390	1	9
60 43 418	1	10
60 63 346	1	9
60 63 349	1	8
60 73 567 25	1	8
60 73 568 25	1	8
60 73 569	1	11
60 73 570	1	10
60 73 571 25	1	9
60 73 572 25	1	2
60 73 573 25	1	8
60 73 574	1	8
63 00 156	1	9
63 00 215	1	11
63 00 263	1	2
63 00 300	1	9
68 00 400	1	11
69 00 653	1	9
69 00 688	1	8
69 00 695	1	11
69 00 943	1	2
69 00 945	1	2
69 00 948	1	11
69 00 974	15m	9