

<b>D</b>	<b>Ersatzteilliste</b>	<b>Motorsense</b>	<b>107 B</b>	<b>Inhaltsverzeichnis</b>	<b>Seite</b>
				Motor, Kurbelwelle, Zündung	2
				Luftfilter, Vergaser, Auspuff	4
				Benzintank	5
				Starter	6
				Gehäuse-Anbauteile	7
				Schaftrohr, Gasgriff, Bikegriff	8
				Getriebe, Schutz, Schneidwerkzeug	9
				Richtlinien für die Bestellung	10
				Ersatzteile	10
<b>GB</b>	<b>Spare parts list</b>	<b>Brushcutter</b>	<b>107 B</b>	<b>Table of contents</b>	<b>Page</b>
				Engine, crankshaft, ignition	2
				Air filter, carburetor, exhaust	4
				Fuel tank	5
				Starter	6
				Attachment parts - housing	7
				Shaft tube, throttle grip, handle "bike"	8
				Gear, protection, cutter	9
				Directions for ordering	10
				Spare parts	10
<b>F</b>	<b>Liste de pièces de rechange</b>	<b>Debroussailleuses</b>	<b>107 B</b>	<b>Table des matières</b>	<b>Page</b>
				Moteur, vile brequin, allumage	2
				Filtre à air, carburateur, echappement	4
				Réservoir à essence	5
				Lanceur	6
				Pièces de montage du carter	7
				Tube, poignée acc, poignée "bike"	8
				Engrenage, protection, outil de coupe	9
				Directives pour les comandes	10
				Pièces de rechange	10
<b>E</b>	<b>Lista de piezas de recambio</b>	<b>Desbrozadora</b>	<b>107 B</b>	<b>Indice</b>	<b>Página</b>
				Motor, cigüeñal, encendido	2
				Filtro de aire, carburador, escape	4
				Deposito	5
				Arranque	6
				Cárter - y piezas adicionales	7
				Tubo, acelerador, mango "bike"	8
				Engranaje, proteccion, herramienta de corte	9
				Directivas de pedido	10
				Piezas de recambio	10

Motor, Kurbelwelle, Zündung
Engine, crankshaft, ignition
Moteur, vile brequin, allumage
Motor, cigüeñal, encendido



Bild-Nr. Pos.-No. No.Pos. Pos.-No.	Bestell-Nr. Order-No. No. de Cde Ref.-Nr.	Menge Quantity Nombres Cantidad	Motor, Kurbelwelle, Zündung	Engine, crankshaft, ignition	Moteur, vile brequin, allumage	Motor, cigüeñal, encendido
1	20 00 683251	1	Motor komplett 29 ccm	Engine cpl. 29 ccm	Moteur 29 ccm	Motor 29 ccm
2	22 00 303	1	Kurbelwelle	Crankshaft	Vilebrequin	Cigüeñal
3	22 00 422	1	Zylinder + Kolben, Reparaturatz enth.: (-> 3 - 8	Cylinder + piston, repair kit incl. (-> 3 - 8	Cylindre + piston, kit de réparation y inclus (-> 3 - 8	Cilindro + piston, juego de reparacion incl. (-> 3 - 8
4	20 61 226	1	Zylinderfußdichtung	Cylinder foot gasket	Joint de cylindre	Junta del cilindro
5	22 00 423	1	Kolben Ø 35 mm enth.: (-> 5 - 8	Piston incl. (-> 5 - 8	Piston y inclus (-> 5 - 8	Piston incl. (-> 5 - 8
6	20 31 902 25	1	Kolbenbolzen 9/6x26 mm	Piston pin	Axe de piston	Perno de embolo
7	20 48 346	1	Kolbenring 35x1,5 mm	Piston ring	Segment de piston	Anillo de piston
8	00 55 278	2	Sicherungsring 9x0,8 mm (-))	Circlip (-))	Arrêt axe de piston (-))	Anillo de seguridad (-))
9	21 00 258	1	Kurbelgehäuse	Crankcase	Carter moteur	Carter cigüenal
10	00 52 226	1	Nadelkäfig 9x13x12,5 mm	Needle sleeve	Douille	Casquillo (-)
11	00 50 174	2	Kugellager 12x28x8 mm	Ball bearing	Roulement à billes	Cojinete de bolas
12	00 54 278	2	Wellendichtring 12x22x5 mm	Oil seal	Joint spy	Reten
13	20 61 227	1	Dichtung Kurbelgehäuse	Gasket	Joint	Junta
14	00 18 412	4	Zylinderschraube M5x35 mm	Screw	Vis	Tornillo
15	00 18 342	4	Zylinderschraube M5x60 mm	Screw	Vis	Tornillo
16	00 72 144	4	Sicherungsscheibe 5 mm	Safety washer	Rondelle de sécurité	Arandela seguridad
17	20 61 518	1	Vergaserstuzendichtung 0,8 mm	Manifold gasket	Joint d'admission	Junta carburador
18	23 00 901	1	Vergaserstutzen enth.: (-> 18 , 19	Manifold incl. (-> 18 , 19	Pipe d'admission y inclus (-> 18 , 19	Munon carburador incl. (-> 18 , 19
19	00 20 101	2	Sechskantmutter M5 (-)	Nut (-)	Écrou frein M5 (-)	Tuerca (-)
20	00 18 337	2	Zylinderschraube M5x20 mm	Screw	Vis	Tornillo
21	23 00 888	1	Zündkerze USR 4AC	Spark plug	Bougie	Bujia
22	00 75 100	1	Scheibenfeder 2x3,7 mm ->)	Disc spring ->)	Clavette ->)	Chaveta ->)
23	00 72 176	1	Spannscheibe 8,2x20x1 mm	Tension spring	Rondelle de tension	Arandela elastica
24	00 21 258	1	Sechskantmutter M8x1x6,5 mm	Nut	Écrou	Tuerca
25	23 00 867	1	Zündmodul enth. (-> 25, 26	Ignition coil incl. (-> 25, 26	Bobine y inclus (-> 25, 26	Bobina incl. (-> 25, 26
26	00 84 744	1	Zündkerzenstecker (-)	Spark plug cap (-)	Capuchon de bougie (-)	Terminal de bujia (-)
27	00 15 299	2	Stiftschraube M4x35 mm	Screw	Boulon fileté	Tornillo
28	00 33 401	2	Distanzhülse	Distance sleeve	Entretoise	Casquillo
29	00 72 148	2	Sicherungsscheibe 4 mm	Safety washer	Rondelle de sécurité	Arandela seguridad
30	00 30 101	1	Scheibe 4,3 mm	Washer	Rondelle	Arandela
31	00 28 118	2	Sechskantmutter M4	Nut	Écrou	Tuerca
32	00 84 894	1	Kurzschlusskabel	Short circuit cable	Câble	Cable cortocircuito
33	00 31 626	1	Scheibe 8,1x32x1 mm	Washer	Rondelle	Arandela
34	35 00 465	1	Fliehkraftkupplung M8x1 enth.: (-> 34, 35	Centrifugal clutch incl. (-> 34, 35	Embrayage centrifuge y inclus (-> 34, 35	Embrague centrifugal incl. (-> 34, 35
35	06 10 572	1	Kupplungsfeder (-)	Clutch spring (-)	Ressort d'embrayage (-)	Resorte de embrague (-)
36	24 00 330	1	Lüfterrad enth.: (-> 36- 39	Fan wheel incl. (-> 36- 39	Volant magnétique y inclus (-> 36- 39	Turbina incl. (-> 36- 39
37	00 73 449	2	Drehfeder	Spring	Ressort	Resorte
38	20 42 896	2	Rasthebel	Lever	Levier	Palanca
39	00 18 454	2	Zyl-Schraube M5x18 mm (-)	Screw (-)	Vis (-)	Tornillo (-)



Bild-Nr. Pos.-No. No.Pos. Pos.-No.	Bestell-Nr. Order-No. No. de Cde Ref.-Nr.	Menge Quantity Nombres Cantidad	Luftfilter, Vergaser, Auspuff	Air filter, carburetor, exhaust	Filtre à air, carbureteur, échappement	Filtro de aire, carburetor, escape
1	20 61 518	1	Vergaserstutzendichtung 0,8 mm	Manifold gasket	Joint d'admission	Junta carburador
2	23 00 901	1	Vergaserstutzen enth.: (-> 2, 3)	Manifold incl. (-> 2, 3)	Pipe d'admission y inclus (-> 2, 3)	Munon carburador incl. (-> 2, 3)
3	00 20 101	2	Sechskantmutter M5 <-)	Nut <-)	Écrou frein M5 <-)	Tuerca <-)
4	00 18 337	2	Zylinderschraube M5x20 mm	Screw	Vis	Tornillo
5	20 61 533	1	Vergaserdichtung	Carburetor gasket	Joint de carburateur	Junta carburador
6	23 00 865 10	1	Vergaser WT 945 D-Cut	Carburetor	Carburateur	Carburador
7	20 74 600	1	Haltering	Ring	Bague de retient	Anillo
8	25 00 811	1	Filtergehäuse enth. (-> 8 - 11)	Filter housing incl. (-> 8 - 11)	Carter filtre y inclus (-> 8 - 11)	Carter de filtro incl. (-> 8 - 11)
9	40 43 106	1	Chokeklappe	Choke flap	Volet choke	Mariposa
10	20 74 966	1	Chokeknopf	Knob	Bouton	Boton
11	00 33 371	2	Distanzhülse ->)	Distance sleeve ->)	Entretoise ->)	Casquillo ->)
12	00 18 378	2	Zyl. Schraube M5x55 mm	Screw	Vis	Tornillo
13	00 72 140	1	Scheibe 5,2x12x0,5 mm	Washer	Rondelle	Arandela
14	00 61 360	1	Scheibe 6,8x10x1,2 mm	Washer	Rondelle	Arandela
15	00 34 100	1	Sicherungsscheibe 5mm	Safety washer	Rondelle de sécurité	Arandela seguridad
16	25 00 816	1	Luftfilter	Air filter	Filtre à air	Filtro de aire
17	20 74 650	1	Luftfiltergehäuse Oberteil	Filter lid	Chapeau filtre	Tapa de filtro
18	00 18 366	2	Vierkantschraube M5x58 mm	Screw	Vis	Tornillo
19	20 45 764	1	Isolierblech	Isolation plate	Tôle	Chapa
20	20 61 198	1	Auspuffdichtung	Exhaust gasket	Joint d'échappement	Junta escape
21	25 00 836	1	Auspuff	Exhaust	Échappement	Escape
23	00 72 144	4	Sicherungsscheibe 5 mm	Tension washer	Rondelle de tension	Arandela elastica
24	00 28 137	2	Sechskantmutter M5	Nut	Écrou frein m5	Tuerca
25	43 00 278	1	Tankschutzblech	Tank protection plate	Plaque de protection de reservoir	Chapa de proteccion del tanque
26	00 18 337	1	Zylinderschraube M5x20 mm	Screw	Vis	Tornillo
27	00 28 157	1	Blechmutter M5	Nut	Écrou	Tuerca
28	00 68 370	1	Selbstklebeschild "Choke"	Sticker "Choke"	Autocollant "Choke"	Adhesivo "Choke"
29	05 10 984	1	Reparatursatz - Vergaser	Repair-kit - carburetor	Kit de réparation - carbureteur	Juego de reparacion - carburador



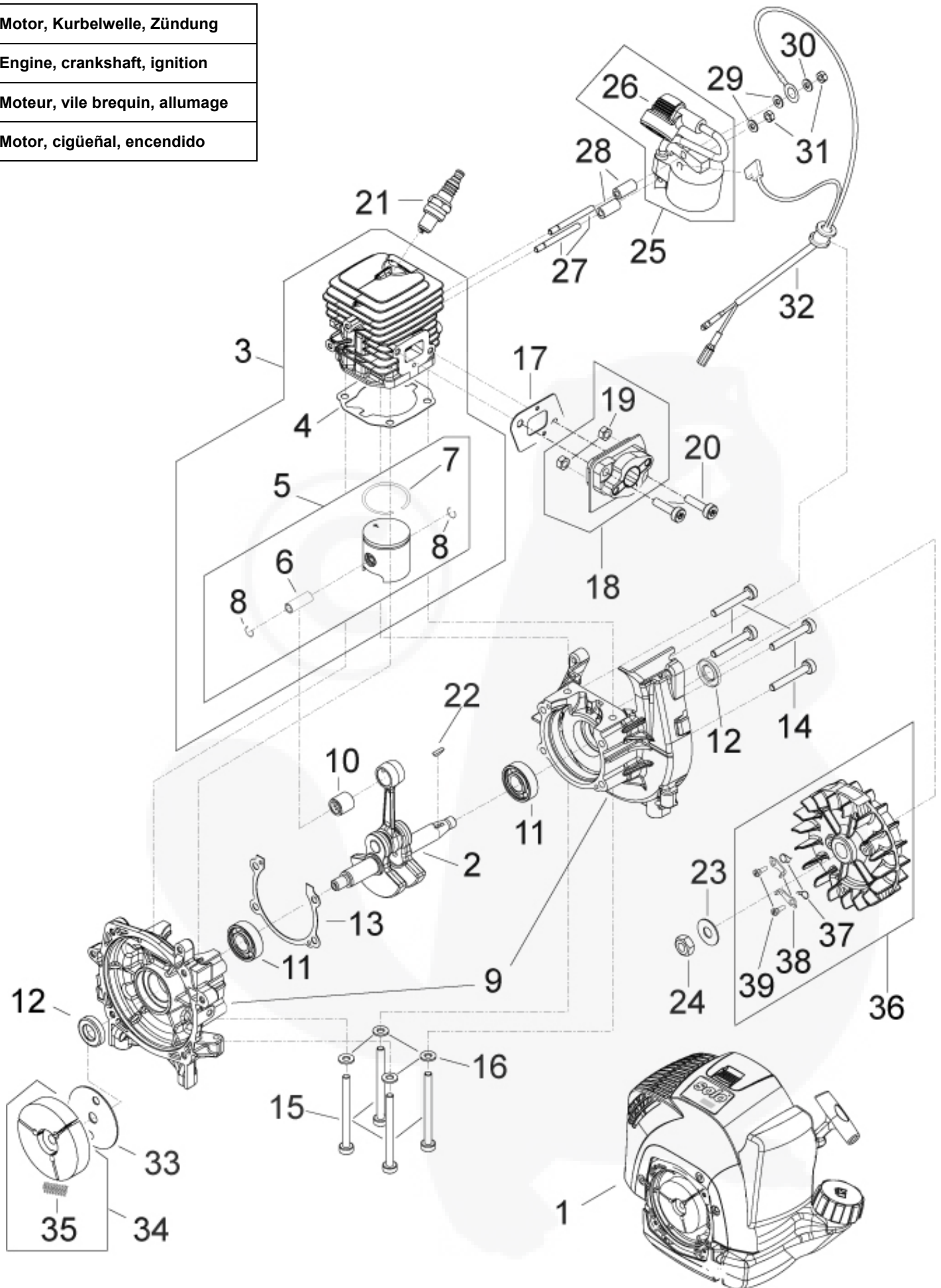

Bild-Nr. Pos.-No. No.Pos. Pos.-No.	Bestell-Nr. Order-No. No. de Cde Ref.-Nr.	Menge Quantity Nombres Cantidad	<b>Benzintank</b>	<b>Fuel tank</b>	<b>Réservoir à essence</b>	<b>Deposito</b>
1	27 00 450	1	Benzintank enth. (-> 1 - 9	Fuel tank incl. (-> 1 - 9	Réservoir à essence y inclus (-> 1 - 9	Deposito incl. (-> 1 - 9
2	60 63 342	1	Schlauch 3x164 mm Kraftstoff	Fuel hose	Tuyau	Tubo
3	27 00 434	1	Schlauch Entlüftung	Ventilation hose	Tuyau d'aération	Tubo
4	00 64 419	1	Schlauch 3x1,5x85 mm Benzinrücklauf	Hose	Tuyau	Tubo
5	00 94 277	4	Dämpfungsgummi	AV element	Amortisseur	Elemento AV
6	20 74 141	4	Distanzhülse	Distance sleeve	Entretoise	Casquillo
7	27 00 187	1	Tankverschluss enth. (-> 7, 8	Tank lid incl. (-> 7, 8	Bouchon de réservoir y inclus (-> 7, 8	Cierre de deposito incl. (-> 7, 8
8	00 62 345	1	O-Ring 29x4 mm <-)	O-ring <-)	Joint torique <-)	Anillo <-)
9	27 00 141	1	Filter Benzinsucher <-)	Fuel pick-up <-)	Crépine d'essence <-)	Filtro <-)
11	00 30 102	4	Scheibe 5,3 mm	Washer	Rondelle	Arandela
12	00 18 339	4	Zylinderschraube M5x30 mm	Screw	Vis	Tornillo
13	20 73 696	1	Stützleiste	Support ledge	Liston de support	Liston de soporte
14	00 18 344	4	Zylinderschraube M6x10 mm	Screw	Vis	Tornillo
15	20 74 899 52	1	Klemme	Clamp	Collier	Abrazadera
16	00 18 363	1	Linsenschraube 5x20 mm	Screw	Vis	Tornillo

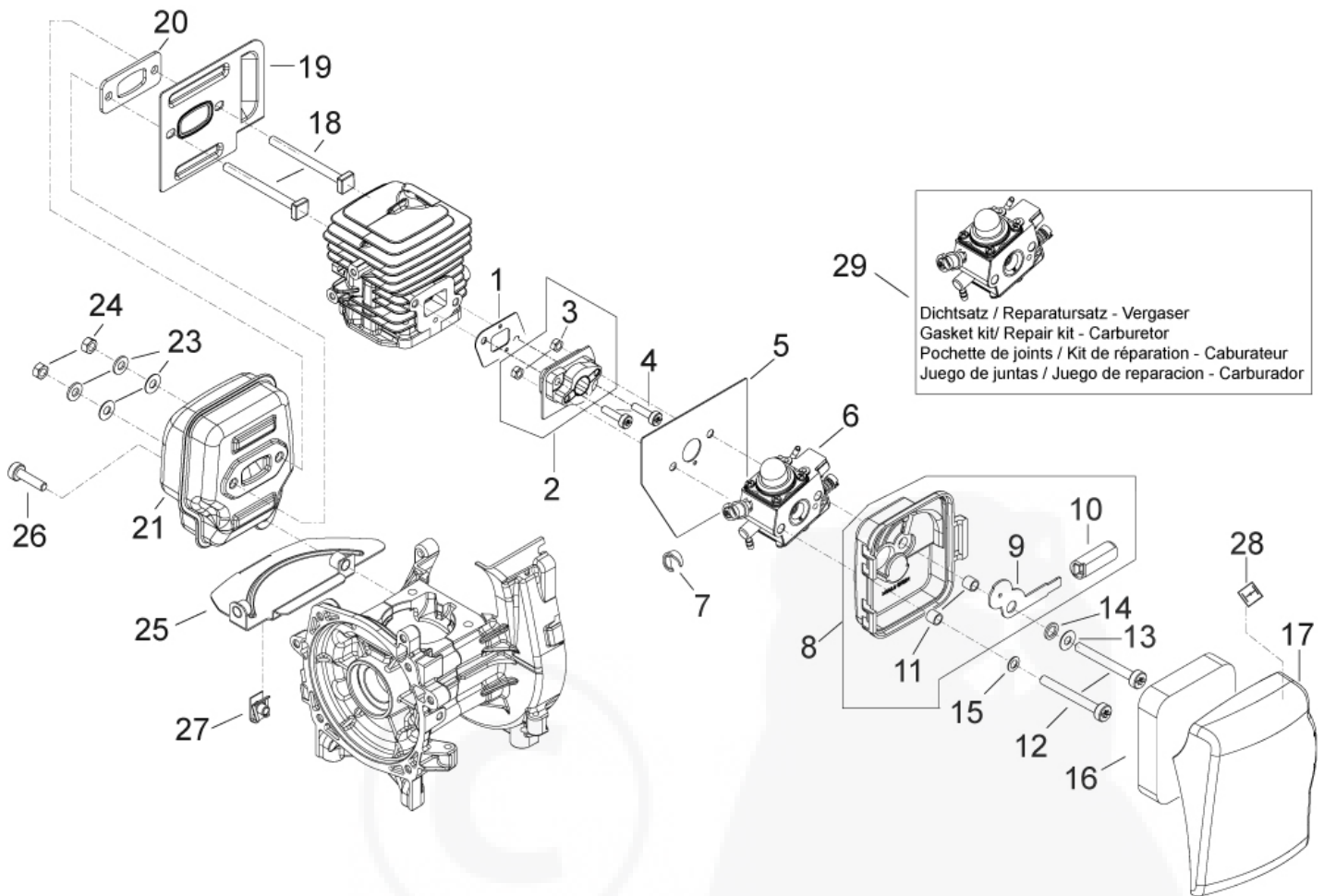

Bild-Nr. Pos.-No. No.Pos. Pos.-No.	Bestell-Nr. Order-No. No. de Cde Ref.-Nr.	Menge Quantity Nombres Cantidad	Starter	Starter	Lanceur	Arranque
1	20 73 697	1	Luffführung	Air guide	Conduit d'air	Guia aire
2	21 00 935	1	Motor-Abdeckhaube	Cover	Capot	Cubierta
3	00 28 157	2	Blechmutter M5	Nut	Écrou	Tuerca
4	26 00 350	1	Starter enth. (-> 4 - 6)	Starter incl. (-> 4 - 6)	Lanceur y inclus (-> 4 - 6)	Arranque incl. (-> 4 - 6)
5	20 74 360	1	Startergriff	Starter grip	Poignée lanceur	Empunadura
6	00 63 185	1	Starterseil 3x1050 gewachst <-)	Starter rope <-)	Câble lanceur <-)	Cuerda de arranque <-)
7	00 68 630	1	SKS SOLO	Decal	Autocollant Solo	Adhesivo
8	00 18 338	4	Zylinderschraube M5x25 mm	F.H. screw	Vis	Tornillo

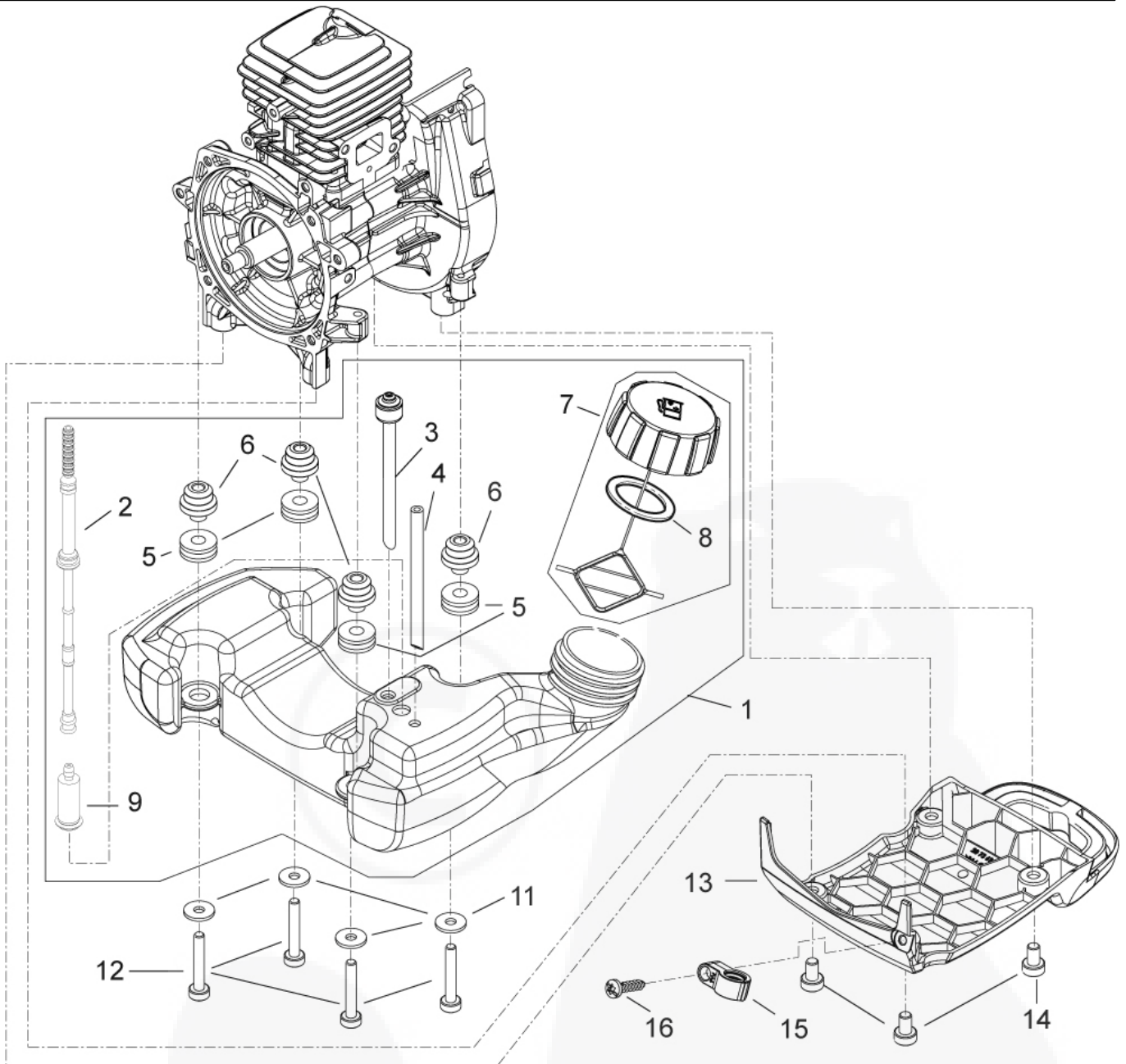

Bild-Nr. Pos.-No. No.Pos. Pos.-No.	Bestell-Nr. Order-No. No. de Cde Ref.-Nr.	Menge Quantity Nombres Cantidad	Gehäuse-Anbauteile	Attachment parts - housing	Pièces de montage du carter	Cárter - y piezas adicionales
1	43 00 278	1	Tankschutzblech	Tank protection plate	Plaque de protection de reservoir	Chapa de proteccion del tanque
2	00 28 157	1	Blechmutter M5	Nut	Écrou	Tuerca
3	20 43 325	1	Widerlager	Counter bearing	Roulement butée	Cojinete de tope
4	00 18 449	1	Zylinderschraube M5x12 mm	Screw	Vis	Tornillo
7	00 11 105	1	Verstellschraube M6x14 mm	Adjust screw	Vis	Tornillo
8	00 20 116	1	Sechskantmutter M6	Nut	Écrou frein m5	Tuerca
9	20 73 698	1	Lufthaube	Air cover	Conduit d'air capot	Guia aire cubierta
10	00 18 335	1	Zylinderschraube M5x12 mm	Screw	Vis	Tornillo
11	20 73 697	1	Lufführung	Air guide	Conduit d'air	Guia aire
12	21 00 935	1	Motor-Abdeckhaube	Cover	Capot	Cubierta
13	20 73 699	1	Seitenhaube	Knee part	Piece angulaire	Pieza angular
14	00 18 337	5	Zylinderschraube M5x20mm	Screw	Vis	Tornillo
15	00 68 331	1	Selbstklebeschild SOLO 107	Decal	Autocollant	Adhesivo
16	00 28 157	2	Blechmutter M5	Nut	Écrou	Tuerca
17	20 74 612	1	Zündkerzenabdeckung	Spark plug cover	Capuchon de bougie	Tapa de bujia
18	26 00 350	1	Starter	Starter	Lanceur	Arranque
19	00 18 338	4	Zylinderschraube M5x25 mm	F.H. screw	Vis	Tornillo
20	20 73 696	1	Stützleiste	Support ledge	Liston de support	Liston de soporte
21	00 18 344	4	Zylinderschraube M6x10 mm	Screw	Vis	Tornillo
22	20 74 899 52	1	Klemme	Clamp	Collier	Abrazadera
23	00 18 363	1	Linsenschraube 5x20 mm	Screw	Vis	Tornillo
24	00 68 630	1	SKS SOLO	Decal	Autocollant Solo	Adhesivo
26	00 31 626	1	Scheibe 8,1x32x1 mm	Washer	Rondelle	Arandela
27	35 00 465	1	Fliehkraftkupplung M8x1 enth.: (-> 27, 28	Centrifugal clutch incl. (-> 27, 28	Embrayage centrifuge y inclus (-> 27, 28	Embrague centrifugal incl. (-> 27, 28
28	06 10 572	1	Kupplungsfeder <-)	Clutch spring <-)	Ressort d'embrayage <-)	Resorte de embrague <-)

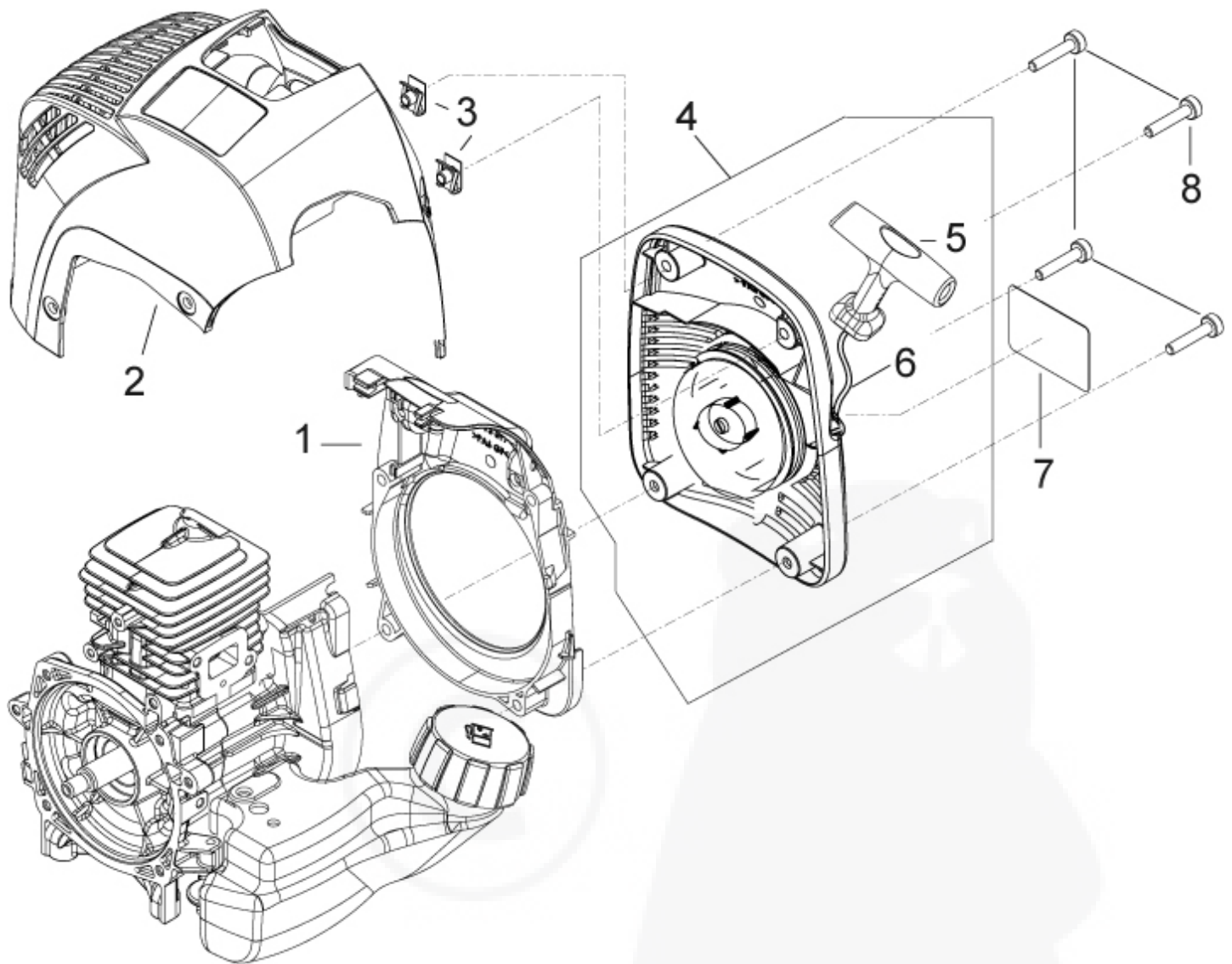

Bild-Nr. Pos.-No. No.Pos. Pos.-No.	Bestell-Nr. Order-No. No. de Cde Ref.-Nr.	Menge Quantity Nombres Cantidad	Schaftrohr, Gasgriff, Loopgriff	Shaft tube, throttle grip, handle "loop	Tube, poignée acc, poignée "loop	Tubo, acelerador, mango "loop
1	21 00 938	1	Flanschgehäuse kpl.	Flange housing	Boîtier bride	Caja de brida
2	63 00 383	1	Schaftrohr	Shaft tube	Tube	Tubo
5	60 35 337	1	Welle M7 x 798mm	Drive shaft	Arbre	Arbol
7	00 18 337	4	Zylinderschraube M5 x 20 mm	F.H. screw	Vis	Tornillo
10	00 66 670	1	Schelle Griffrohr 22d	Clamp	Collier	Abrazadera
11	00 66 671	1	Schelle Griffrohr 24d	Clamp	Collier	Abrazadera
12	00 18 400	4	Zylinderschraube M6 x 35 mm	F.H. screw	Vis	Tornillo
15	60 74 527	1	Halter 24 Bowdenzug Gas.	Cable clip	Clip cable de gaz	Soporte
16	20 73 689	1	Holmbefestigung	Handle bar support	Fixation de longeron	Soporte
17	60 00 330	1	Tragegurt	Carrying strap	Bretelle	Cinturon portador
20	68 00 411	1	Griff 19 Bike komp. enth. (-> 20 - 24	Handle incl. (-> 20 - 24	Poignée cpl. y inclus (-> 20 - 24	Empunadura incl. (-> 20 - 24
21	60 35 148	1	Griffrohr 22x1,5al.bike	Handle tube 22x1,5 al. Bike	Tube de poignée	Tubo de la empunadura
22	68 00 413	1	Griff 24 Gas R.kpl.	Handle	Poignée	Empunadura
23	68 00 414	1	Griff 24 L.kpl.	Handle	Poignée	Empunadura
24	50 74 100	1	Halter 22 Bowdenzug. <-)	Bowden cable clamp <-)	Clip cable de <-)	Soporte <-)
35	21 00 127 52	1	Kupplungsmuffe kompl. enth. (-> 35 - 41	Clutch sleeve cpl. incl. (-> 35 - 41	Manchon d'accouplement cpl. y inclus (-> 35 - 41	Manguito de embrague cpl. incl. (-> 35 - 41
36	00 18 347	1	Zylinderschraube M6x20 mm	Screw	Vis	Tornillo
37	0020 102	1	Sechskantmutter M6	Nut	Écrou	Tuerca
38	68 00 289	1	Rastbolzen mit Rastsperr	bolt	boulon	perno
39	00 18 337	1	Zylinderschraube M5x20mm	Screw	Vis	Tornillo
40	00 94 133	1	Flügelmutter M6	Nut	Écrou	Tuerca
41	00 12 125	1	Schraube M6x35mm <-)	Screw <-)	Vis <-)	Tornillo <-)



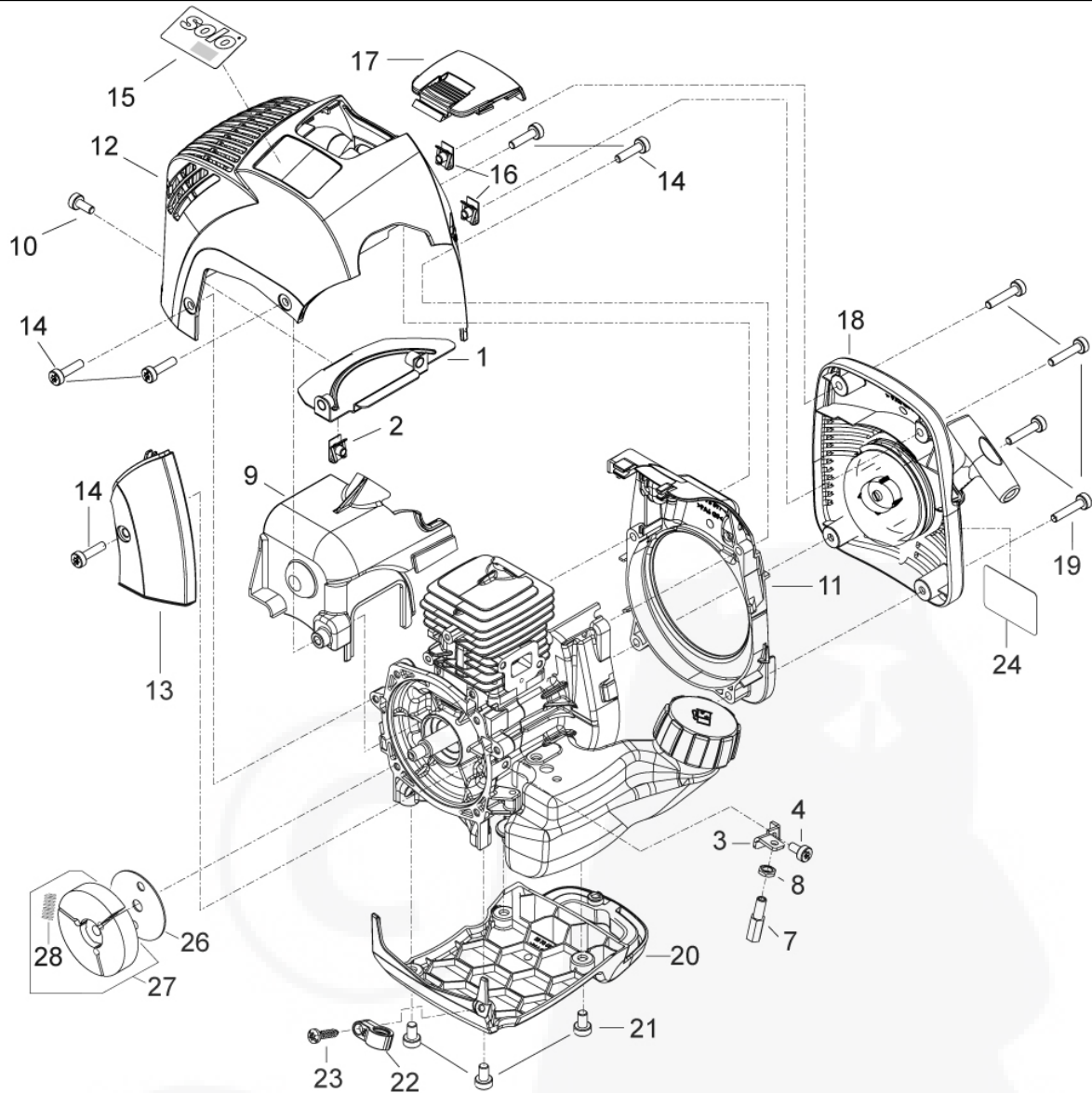

Bild-Nr. Pos.-No. No.Pos. Pos.-No.	Bestell-Nr. Order-No. No. de Cde Ref.-Nr.	Menge Quantity Nombres Cantidad	Getriebe, Schutz, Schneidwerkzeug	Gear, protection, cutter	Engrenage, protection, outil de coupe	Engranaje, proteccion, herramienta de corte
1	63 00 266	1	Schaftrohr enth.: (->1 - 9	Shaft tube incl. (->1 - 9	Tube y inclus (->1 - 9	Tubo incl. (->1 - 9
2	60 35 336	1	Welle 7 x 757 mm	Drive shaft	Arbre	Arbol
3	00 69 381	1	Aufkleber Warnhinweise	Decal	Autocollant	Adhesivo
4	30 00 220 25	1	Getriebe, ZWP enth. (-> 4 - 8	Gear incl. (-> 4 - 8	Engrenage y inclus (-> 4 - 8	Engranaje incl. (-> 4 - 8
5	20 74 904	1	Zwischenstück Wickelschutz	Anti-clogging device	Protecteur d'enroulement	Protec. De arrollamiento
6	00 18 335	3	Zylinderschraube M5x12 mm	Screw	Vis	Tornillo
7	00 31 210	1	Scheibe 12x18x1,2 mm	Washer	Rondelle	Arandela
8	30 31 999	1	Druckstück (-)	Pressure part(-)	Pièce de pression(-)	Pieza de presion (-)
9	20 33 137	1	Verbindungsstück (-)	Hollow shaft connexion (-)	Arbre creux de connexion (-)	Arbol hueco (-)
10	60 73 618 25	1	Schutz	Protection	Protection	Proteccion
11	60 42 848	1	Fadenbegrenzungsmesser	Knife	Couteau	Cuchilla
12	00 30 102	1	Scheibe 5,3 mm	Washer	Rondelle	Arandela
13	00 18 274	1	Linsenschraube 5x16 mm	Screw	Vis	Tornillo
14	60 43 440	2	Schelle	Clamp	Collier	Abrazadera
15	00 21 241	2	Vierkantmutter M5	Nut	Ecrou	Tuerca
16	00 18 339	2	Zylinderschraube M5x30 mm	Screw	Vis	Tornillo
17	69 00 651 7	1	Fadenkopf enth. (->17 - 23	Nylon head incl. (->17 - 23	Tête fils y inclus : (->17 - 23	Cabecal de hilo incl. (->17 - 23
18	20 74 886 45	1	Wickelschutz	Anti-clogging device	Protecteur d'enroulement	Proteccion de arrollamiento
19	06 10 595	1	Gehäuse Oberteil	Cover upper	Carter superieur	Caja superieur
20	06 10 598	1	Seilrolle kpl.	Rope pulley		
21	06 10 600	2	Seilführung	Rope guide	Guide de corde	Guia de cuerda
22	06 10 602	1	Gehäuse Unterteil	Housing sub-frame		
23	69 00 942	15 m	Ersatzfaden Ø 2,4 mm (-)	Replacement line (-)	Recharge fils (-)	Hilo de recambio (-)
24	60 73 977 25	1	Schutzleiste	Protection rail	Listeau de protection	Liston de proteccion
27	30 31 998	1	Druckscheibe	Washer	Rondelle	Disco
28	30 43 427	1	Lauffeller	Nut protector	Disque de glissement	Plato de motriz
29	00 20 223	1	Mutter M10x1,25 mm	Nut	Écrou	Tuerca
			<b>Zubehör</b>	<b>Accessories</b>	<b>Accesorios</b>	<b>Accesorios</b>
30	69 00 948	1	Grasschneideblatt, 4 Zähne Ø 230 mm	Grass cutt. Blade 4-t	Lame herbe, 4-dents	Hoja de corte, 4 dientes
31	60 73 534	1	Transportschutz bis Ø 250 mm	Transport protection	Protection transport	Proteccion transporte

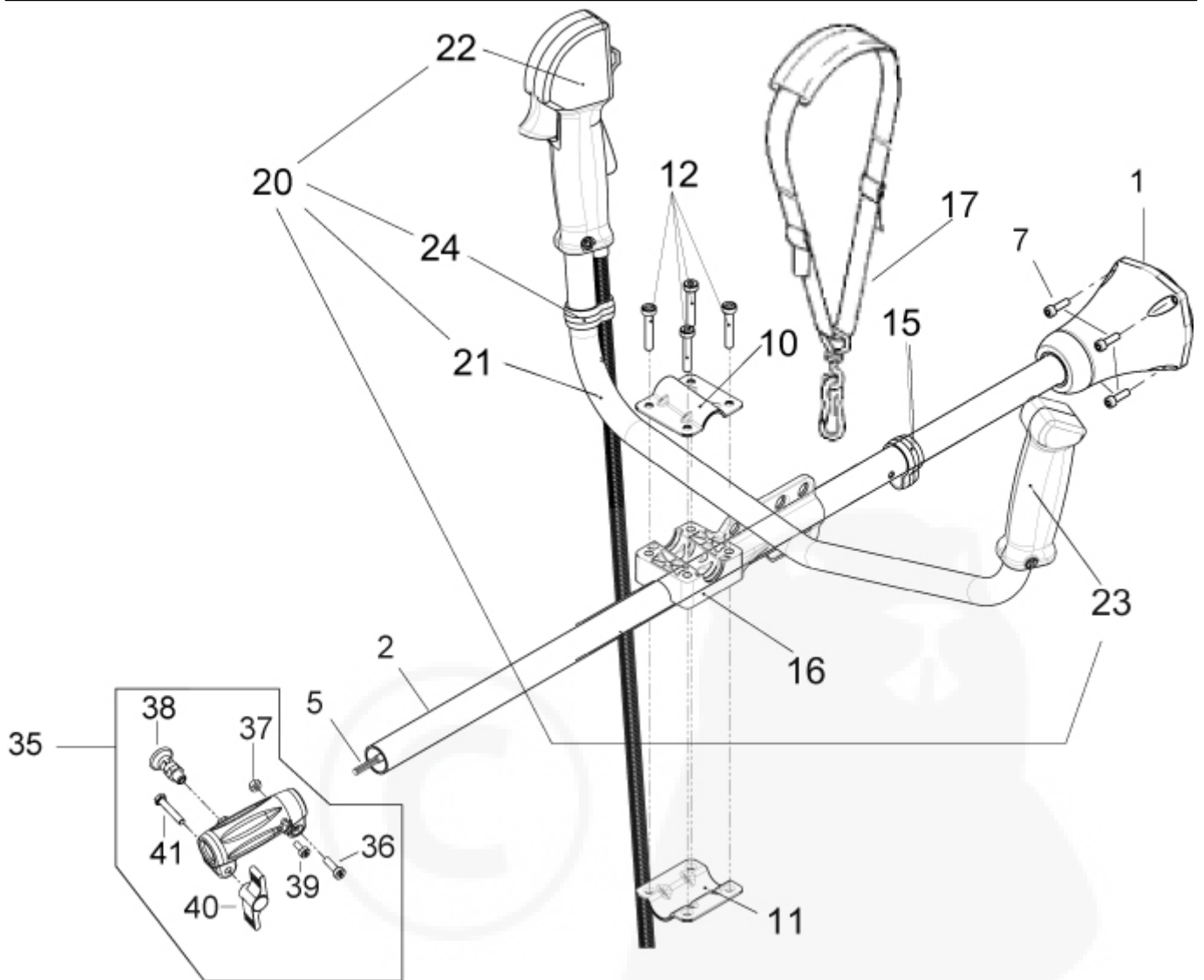
Bestell-Nr. Order-No. No. de Cde Ref.-Nr.	Menge Quantity Nombres Cantidad	Seite Page Page Pagina
00 11 105	1	7
00 12 125	1	8
00 15 299	2	2
00 18 274	1	9
00 18 335	1	7
00 18 335	3	9
00 18 337	2	2
00 18 337	2	4
00 18 337	1	4
00 18 337	5	7
00 18 337	4	8
00 18 337	1	8
00 18 338	4	6
00 18 338	4	7
00 18 339	4	5
00 18 339	2	9
00 18 342	4	2
00 18 344	4	5
00 18 344	4	7
00 18 347	1	8
00 18 363	1	5
00 18 363	1	7
00 18 366	2	4
00 18 378	2	4
00 18 400	4	8
00 18 412	4	2
00 18 449	1	7
00 18 454	2	2
00 20 101	2	2
00 20 101	2	4
00 20 116	1	7
00 20 223	1	9
00 21 241	2	9
00 21 258	1	2
00 28 118	2	2
00 28 137	2	4
00 28 157	1	4
00 28 157	2	6
00 28 157	1	7
00 28 157	2	7
00 30 101	1	2
00 30 102	4	5

Bestell-Nr. Order-No. No. de Cde Ref.-Nr.	Menge Quantity Nombres Cantidad	Seite Page Page Pagina
00 30 102	1	9
00 31 210	1	9
00 31 626	1	2
00 31 626	1	7
00 33 371	2	4
00 33 401	2	2
00 34 100	1	4
00 50 174	2	2
00 52 226	1	2
00 54 278	2	2
00 55 278	2	2
00 61 360	1	4
00 62 345	1	5
00 63 185	1	6
00 64 419	1	5
00 66 670	1	8
00 66 671	1	8
00 68 331	1	7
00 68 370	1	4
00 68 630	1	6
00 68 630	1	7
00 69 381	1	9
00 72 140	1	4
00 72 144	4	2
00 72 144	4	4
00 72 148	2	2
00 72 176	1	2
00 73 449	2	2
00 75 100	1	2
00 84 744	1	2
00 84 894	1	2
00 94 133	1	8
00 94 277	4	5
0020 102	1	8
05 10 984	1	4
06 10 572	1	2
06 10 572	1	7
06 10 595	1	9
06 10 598	1	9
06 10 600	2	9
06 10 602	1	9
20 00 683251	1	2

Bestell-Nr. Order-No. No. de Cde Ref.-Nr.	Menge Quantity Nombres Cantidad	Seite Page Page Pagina
20 31 902 25	1	2
20 33 137	1	9
20 42 896	2	2
20 43 325	1	7
20 45 764	1	4
20 48 346	1	2
20 61 198	1	4
20 61 226	1	2
20 61 227	1	2
20 61 518	1	2
20 61 518	1	4
20 61 533	1	4
20 73 689	1	8
20 73 696	1	5
20 73 696	1	7
20 73 697	1	6
20 73 697	1	7
20 73 698	1	7
20 73 699	1	7
20 74 141	4	5
20 74 360	1	6
20 74 600	1	4
20 74 612	1	7
20 74 650	1	4
20 74 886 45	1	9
20 74 899 52	1	5
20 74 899 52	1	7
20 74 904	1	9
20 74 966	1	4
21 00 127 52	1	8
21 00 258	1	2
21 00 935	1	6
21 00 935	1	7
21 00 938	1	8
22 00 303	1	2
22 00 422	1	2
22 00 423	1	2
23 00 865 10	1	4
23 00 867	1	2
23 00 888	1	2
23 00 901	1	2
23 00 901	1	4

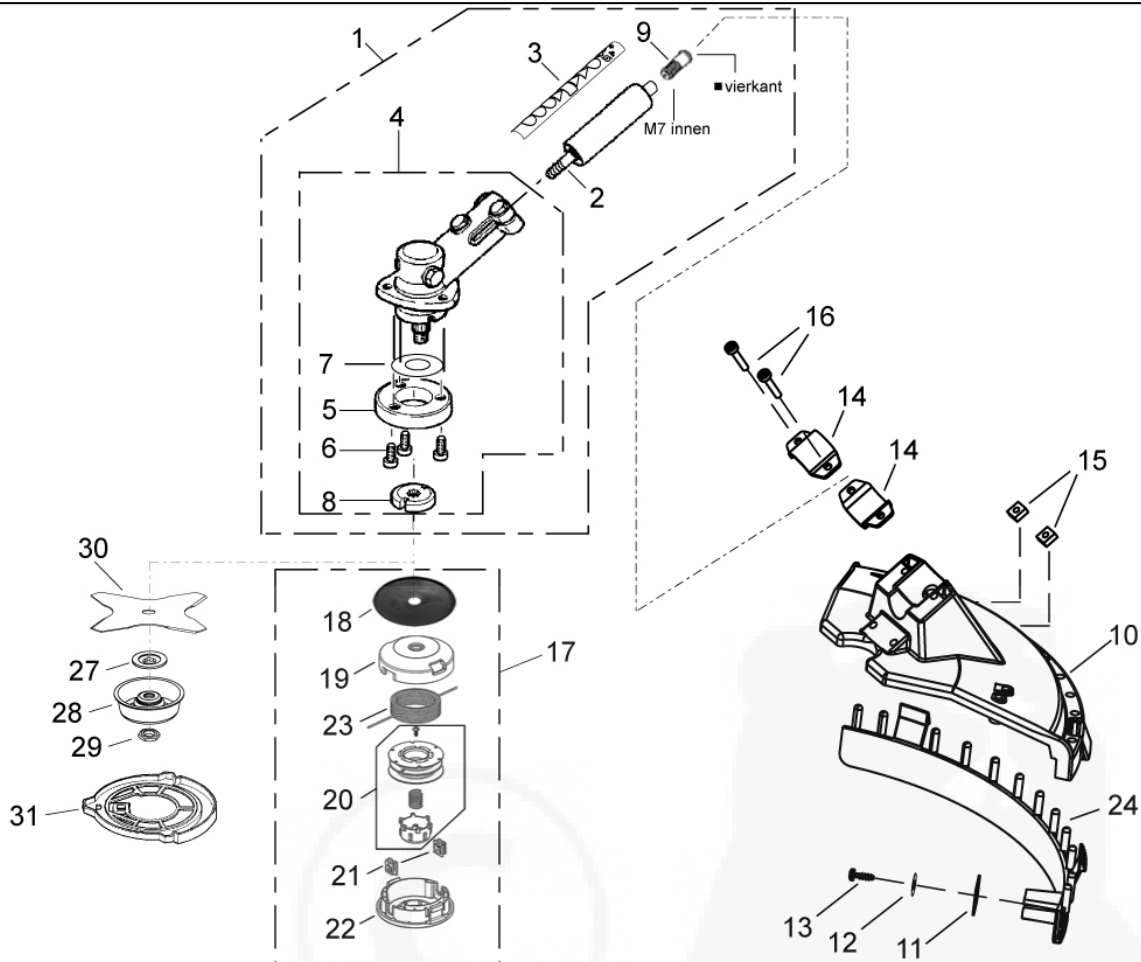
Bestell-Nr. Order-No. No. de Cde Ref.-Nr.	Menge Quantity Nombres Cantidad	Seite Page Page Pagina
24 00 330	1	2
25 00 811	1	4
25 00 816	1	4
25 00 836	1	4
26 00 350	1	6
26 00 350	1	7
27 00 141	1	5
27 00 187	1	5
27 00 434	1	5
27 00 450	1	5
30 00 220 25	1	9
30 31 998	1	9
30 31 999	1	9
30 43 427	1	9
35 00 465	1	2
35 00 465	1	7
40 43 106	1	4
43 00 278	1	4
43 00 278	1	7
50 74 100	1	8
60 00 330	1	8
60 35 148	1	8
60 35 336	1	9
60 35 337	1	8
60 42 848	1	9
60 43 440	2	9
60 63 342	1	5
60 73 534	1	9
60 73 618 25	1	9
60 73 977 25	1	9
60 74 527	1	8
63 00 266	1	9
63 00 383	1	8
68 00 289	1	8
68 00 411	1	8
68 00 413	1	8
68 00 414	1	8
69 00 651 7	1	9
69 00 942	15 m	9
69 00 948	1	9

**D**

**Allgemeine Richtlinien für die Bestellung von Original SOLO Ersatzteilen:**

Voraussetzung für eine reibungslose Erledigung sind folgende Angaben:

1. Ersatzteil-Bestellnummer
2. Gewünschte Anzahl
3. Typenbezeichnung des Geräts

Diese Ersatzteilliste ist für die Lieferung und Ausstattung von SOLO Erzeugnissen unverbindlich. Im Interesse der technischen Weiterentwicklung bleiben Konstruktionsänderungen vorbehalten.

**GB**

**General Directions for Ordering Original SOLO Spare Parts:**

For correct and diligent processing of your order, please give the following information:

1. Spare Part number
2. Quantity
3. Model and serial number
4. Shipping instructions

Delivery is made in accordance with our general sales and delivery conditions. This spare parts list is non-committal for us with regard to delivery and layout of SOLO products. In favour of technical improvements, design modifications are subject to change without notice.

**F**

**Directives générales pour les commandes de pièces de rechange d'origine SOLO:**

Il est indispensable de préciser dans toutes les commandes de pièces:

1. le numéro de référence de la pièce
2. la quantité
3. le type de la machine
4. le mode d'expédition

Les livraisons sont effectuées dans le cadre de nos conditions générales de vente. Toutes modifications réservées.

**E**

**Directivas Generales de pedido de la firma SOLO:**

Por adelantado de un arreglo sin dificultades necesitamos siguientes indicaciones:

1. Número de repuesto
2. Numero de cantidad
3. Modelo y número de serial
4. Instrucción de Envío

Esta lista de repuestos no es obligatoria para los envíos y/o forma de equipo de los productos SOLO. En el interés del constante desarrollo debemos reservarnos el derecho de cambios.