

<b>(D)</b>	<b>Ersatzteilliste</b>	<b>Trennschleifer</b>	<b>881-12</b>	<b>Inhaltsverzeichnis</b>	<b>Seite</b>
				Trennschleifer	
				Motor und Schneidvorrichtung	2
				Griff- und Gehäusebereich	4
				Baugruppen	6
				Motoreinheit	6
				Starter	8
				Antriebseinheit	9
				Griffeinheit	10
				Federlagerungen, Expansionskammer, Mittelkonsole, Haube Anschlussstück	11
				ET-SET „Erstausrüstung“	13
				Ersatzteile, Richtlinien für die Bestellung	14
<b>(GB)</b>	<b>Spare parts list</b>	<b>Cut-Off Machine</b>	<b>881-12</b>	<b>Table of contents</b>	<b>Page</b>
				Cut-Off-Machine	
				Engine and Drive Unit	2
				Grip Unit	4
				Assembly	6
				Engine	6
				Starter	8
				Drive unit	9
				Grip	10
				Support, Suction elbow, Console, Cover, Connection	11
				Spare part set "initial"	13
				Spare parts, Directions for Ordering	14
<b>(F)</b>	<b>Liste de pièces de rechange</b>	<b>Découpeuse à disque</b>	<b>881-12</b>	<b>Table des matières</b>	<b>Page</b>
				Découpeuse à disque	
				Moteur, Unite de Commande	2
				Poignee	4
				Assemblage	6
				Moteur	6
				Lanceur	8
				Unite de commande	9
				Poignee	10
				Pied ressort, Coude d' aspiration, Console, Couvercle, Connection	11
				Pièces de rechange fixé « initiale »	13
				Pièces de rechange, Directives pour les commandes	14
<b>(E)</b>	<b>Lista de piezas de recambio</b>	<b>Tronzadora de muela</b>	<b>881-12</b>	<b>Índice</b>	<b>Página</b>
				Tronzadora de muela	
				Motor, Unidad de Mando	2
				Empuñadura	4
				Ensamblaje	6
				Motor	6
				Arranque	8
				Unidad de mando	9
				Empuñadura	10
				Soporte, Codo de aspiración, Consola, Cubierta, Conexión	11
				Piezas de recambio establecer "inicial"	13
				Piezas de recambio, Directivas de pedido	14

\* Baugruppe  
 Assembly  
 Assemblage  
 Ensamblaje

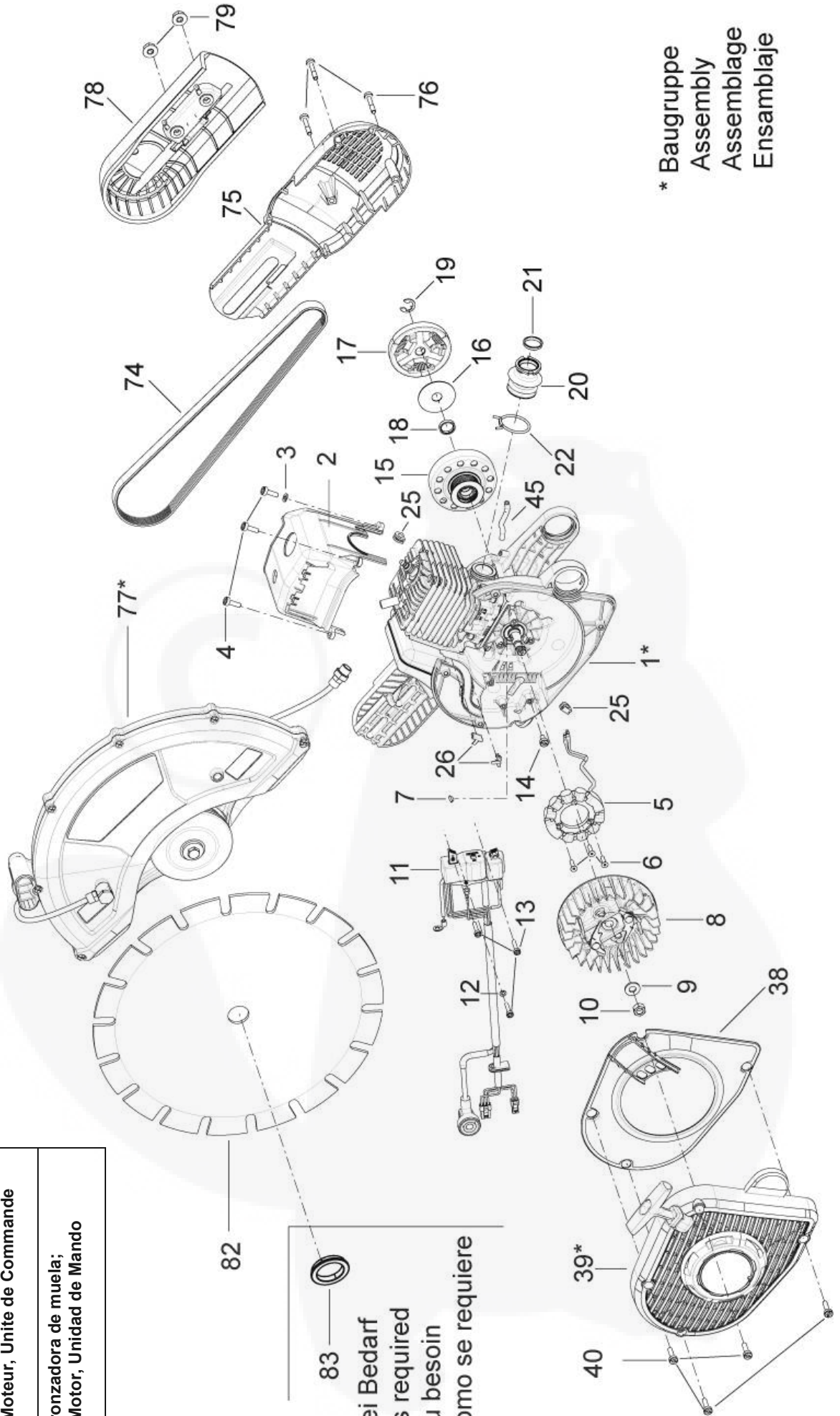

Trennschleifer; Motor und Schneidvorrichtung
Cut-Off Machine; Engine and Drive Unit
Découpeuse à disque ; Moteur, Unite de Commande
Tronzadora de muela; Motor, Unidad de Mando

83 — bei Bedarf  
 as required  
 au besoin  
 como se requiere

Bild-Nr. Pos.-No. No.Pos. Pos.-No.	Bestell-Nr. Order-No. No. de Cde Ref.-Nr.	Menge Quantity Nombres Cantidad	<b>Trennschleifer; Motor und Schneidvorrichtung</b>	<b>Cut-Off Machine; Engine and Drive Unit</b>	<b>Découpeuse à disque ; Moteur, Unite de Commande</b>	<b>Tronzadora de muela; Motor, Unidad de Mando</b>
1*	21 00 676	1	Motoreinheit	Engine	Moteur	Motor
2	60 73 540	1	Zylinderhaube	Cylinder cover	Capot cylindre	Tapa del cilindro
3	00 30 108	1	Scheibe 5,3	Washer	Rondelle	Arandela
4	00 18 336	3	Zyl. Shr. M5x16	Screw	Vis	Tornillo
5	23 00 447	1	Generator	Generator	Generateur	Generador
6	00 13 287	3	Senk Shr. M4x16	Screw	Vis	Tornillo
7	00 75 101	1	Scheibenfeder 3x3,7	Woodruff key	Clavette demi lune	Chaveta
8	24 00 328	1	Lüfferrad	Flywheel	Turbine	Rueda de ventilación
9	00 72 145	1	Si. Scheibe 8	Circlip	Rondelle crantee	Arandela
10	00 20 145	1	6kt. Mu. M8x1	Nut	Écrou	Tuerca
11	23 00 696	1	Zünder	Ignition	Bobine	Bobina
12	00 30 101	1	Scheibe 4,3	Washer	Rondelle	Arandela
13	00 18 327	3	Zyl. Shr. M4x20	Screw	Vis	Tornillo
14	00 18 334	1	Zyl. Shr. M5x10	Screw	Vis	Tornillo
15	35 00 483	1	Kupplungsglocke	Clutch drum	Cloche embrayage	Campana embrague
16	60 42 850	1	Fuehrungsscheibe 12,1x44,6x1	Washer	Rondelle	Arandela
17	35 00 470	1	Kupplung M12x11. Fliehkraft	Centrifugal clutch	Embrayage centrifuge	Embrague centrífugo
18	00 33 429	1	Distanzbuchse 15x18,6x4,2	Spacer tube	Tube entretoise	Tubo espaciador
19	00 55 161	1	Si. Scheibe 9	Washer	Circlips	Clip
20	60 63 324	1	Ansaugschlauch"	Manifold	Tube d'aspiration	Tubo de aspiración
21	60 43 137	1	Einsatz-Ansaugschlauch	Suction hose	Tube d'aspiration	Tubo de aspiración
22	00 73 451	1	Schlauchklemme	Clamp		Abrazadera
25	00 66 335	2	Tuelle 6,5/9x2,2/6,2	Grommet	Passe fil	Boca
26	00 66 678	2	U-Klammer	Clamp	Crampon	Abrazadera
38	60 73 541	1	Luftführung	Air guide	Guide d'air	Guía de aire
39*	26 00 257	1	Starter	Starter	Lanceur	Arranque
40	00 18 337	4	Zyl. Shr. M5x20	F.h. screw	Vis	Tornillo
45	00 64 245	1	Impulsschlauch 3,1X1,3x65mm	Impulse hose	Tuyau	Tubo flex. de pulso
74	00 57 114	1	Rippenband	Belt	Cinture	Correa
75	60 73 710	1	Abdeckung Kupplung	Cover clutch	Couvercle	Tapa
76	00 18 460	3	Schaftschraube M5x30	Screw	Vis	Tornillo
77*	33 00 112	1	Antriebseinheit	Drive unit	Unite de commande	Unidad de mando
78	61 00 338	1	Abdeckung Antriebseinheit	Cover	Couvercle	Cubierta
79	00 24 106	2	Flanschmutter M8	Nut	Écrou	Tuerca
82	00 80 112	1	Trennscheibe 12"	Cutting disc	Rondelle	Disco de tronzar
83	60 31 810	1	Adapter 1"	Adapter 1"	Adaptateur 1"	Adaptor 1"

Trennschleifer
Griff- und Gehäusebereich
Cut-Off Machine
Grip Unit
Découpeuse à disque
Poignée
Tronzadora de muela
Empuñadura

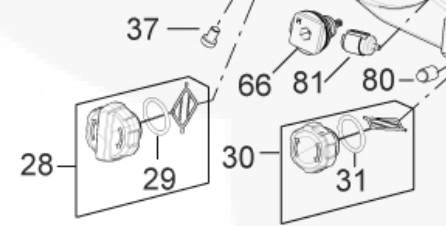
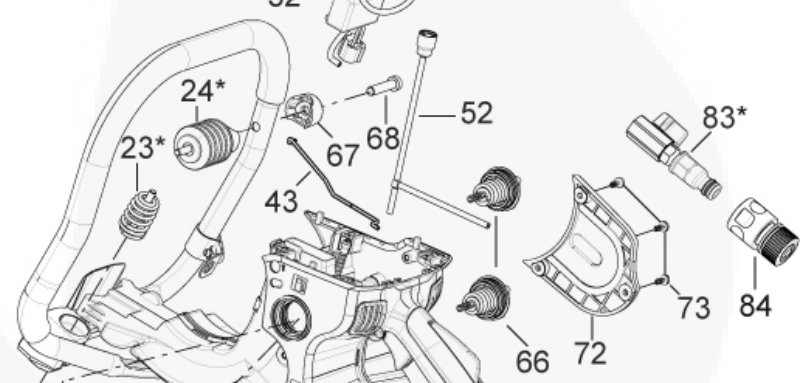
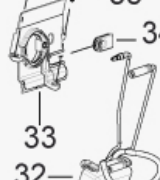
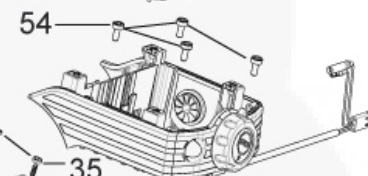
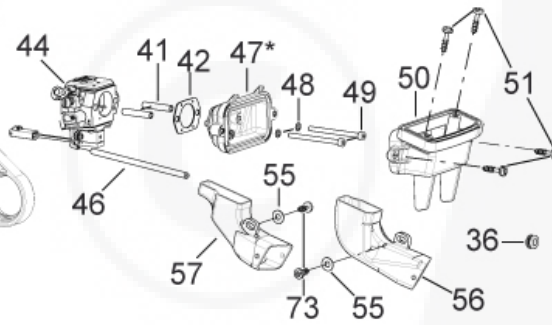
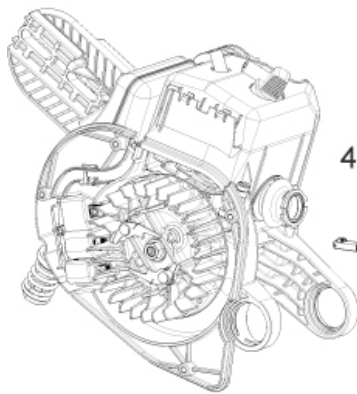
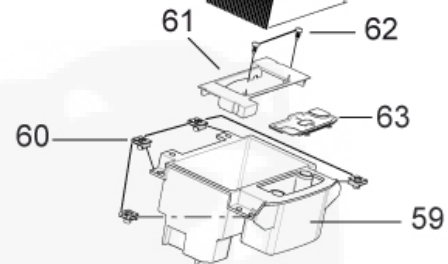
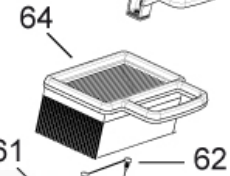
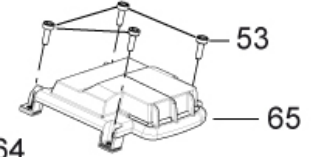
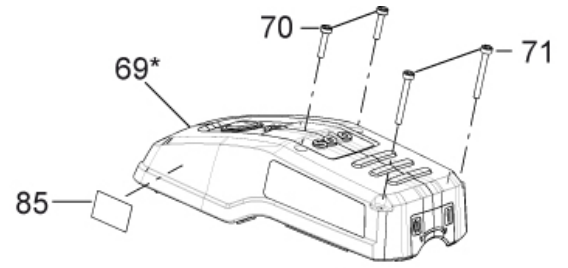

\* Baugruppe  
 Assembly  
 Assemblage  
 Ensamblaje

Bild-Nr. Pos.-No. No.Pos. Pos.-No.	Bestell-Nr. Order-No. No. de Cde Ref.-Nr.	Menge Quantity Nombres Cantidad	<b>Trennschleifer Griff- und Gehäusebereich</b>	<b>Cut-Off Machine Grip Unit</b>	<b>Découpeuse à disque Poignee</b>	<b>Tronzadora de muela Empuñadura</b>
23*	63 00 273	1	Federlagerung Fuß	Support	Pied ressort	Soporte
24*	63 00 275	1	Federlagerung Haltebügel	Support	Support	Soporte
27*	61 00 477	1	Griffeinheit	Grip	Poignee	Depósito
28	27 00 240	1	Tankverschluss Benzin enth. (-> 28, 29	Tank lid incl. (-> 28, 29	Fermeture reservoir y inclus (-> 28, 29	Tapa del deposito incl. (-> 28, 29
29	00 62 347	1	O. Ring 25x3 <-)	O-ring <-)	Anneau <-)	Anillo <-)
30	27 00 241	1	Tankverschluss Öl enth. (-> 30, 31	Tank lid incl. (-> 30, 31	Fermeture reservoir y inclus (-> 30, 31	Tapa del depósito incl. (-> 30, 31
31	00 62 347	1	O. Ring 25x3 <-)	O-ring <-)	Anneau <-)	Anillo <-)
32	00 84 515	1	Elektronikbox	Box	Box	Mando Electrónico
33	60 74 542	1	Flanschring	Flange ring	Anneau de bride	Anillo de brida
34	80 63 249	1	Kabeldurchführung	Cable grommet	Passe-cable	Manguito de cable
35	00 18 355	2	Li. Shr.4x16	Screw	Vis parker	Tornillo
36	00 66 429	1	Tuelle Kabel	Grommet	Passe-cable	Manguito de cable
37	00 10 362	1	Zyl. Shr.M8x12	F.h. screw	Vis	Tornillo
41	00 64 328	2	Isolierschlauch 4,0x0,5	Spacer tube	Tuyau d'entretoise	Tubo distanciador
42	20 61 444	1	Vergaserdichtung	Gasket carburettor	Joint de carburateur	Junta carburador
43	20 36 285	1	Gasgestänge	Throttle linkage	Tinglerie	Varilla de gas
44	23 00 874	1	Vergaser HD-55 i-lube	Carburetor	Carburateur	Carburador
46	00 64 246	1	Schlauch fpm 2x1,5x140	Hose	Tuyau	Tubo
47*	23 00 871	1	Expansionskammer	Suction elbow	Coude d' aspiration	Codo de aspiración
48	00 34 152	2	Si. Scheibe 4	Circlip	Rondelle crantee	Arandela estriada
49	00 18 455	2	Zyl. Shr.m4x55	Screw	Vis	Tornillo
50	23 00 872	1	Ansaugkrümmer	Suction elbow	Coude d' aspiration	Codo de aspiración
51	00 18 274	4	Li. Shr.5x16	Lens head screw	Vis parker	Tornillo
52	27 00 214	1	Entlueftungsschlauch	Ventilation hose	Tuyau de ventilation	Tubo de ventilación
53	00 18 336	4	Zyl. Shr. M5x16	Screw	Vis	Tornillo
54	00 18 335	4	Zyl. Shr. M5x12	Screw	Vis	Tornillo
55	00 72 140	2	Scheibe 5,2x12x0,5	Disc spring	Rondelle belleville	Arandela
56	80 74 746	1	Schnorchel Rechts	Snorkel right	Respirateur	Respirador
57	80 74 747	1	Schnorchel Links	Snorkel left	Respirateur	Respirador
58*	61 00 486	1	Mittelkonsole	Console	Console	Consola
59	60 74 870	1	Filtergehäuse	Filter housing	Carter filtre	Cárter de filtro
60	00 28 156	4	Blechmutter M5	Speed nut m5	Ecrou m5	Tuerca m5
61	80 74 772	1	Filterkastenblende	Screen	Masque	Tapa
62	00 13 285	2	Li. Bl. Shr.3,5x9,5	Screw	Vis	Tornillo
63	25 00 771	1	Siebeinsatz	Screen insert	Insertion de tamis	Inserción de tamiz
64	25 00 793	1	Luftfilter	Main filter	Filtro principal	Filtro principal
64	25 00 794	10	Luftfilter	Main filter	Filtro principal	Filtro principal
64	25 00 795	20	Luftfilter	Main filter	Filtro principal	Filtro principal
65	25 00 510	1	Filterdeckel	Filter cover	Couvercle filtre	Tapa de filtro
66*	63 00 274	3	Federlagerung Tankgehäuse	Spring support	Support de ressort	Soporte de resorte
67	60 74 832	1	Klemmstück	Clamp	Collier	Abrazadera
68	00 10 264	1	Zyl. Shr.M8x35	Screw	Vis	Tornillo
69*	61 00 240	1	Haube Trennschleifer	Cover	Couvercle	Cubierta
70	00 18 338	2	Zyl. Shr. M5x25	F.h. screw	Vis	Tornillo
71	00 18 389	2	Zyl. Shr. M5x45	F.h. screw	Vis	Tornillo
72	60 74 453	1	Abdeckung Federelement	Cover	Couvercle	Tapa
73	00 18 361	5	Li. Shr.5x12	Screw	Vis parker	Tornillo
80	67 00 121	1	Oelsieb	Oil strainer	Tamis d' huile	Tamiz de aceite
81	27 00 135	1	Filter Benzin	Filter fuel pick-up	Fitre essence	Filtro gasolina
83*	00 65 324	1	Anschlussstück 1/4"	Connection	Connection	Conexión
84	00 65 325	1	Schlauchkupplung	Hose coupling	Raccord symetrique	Acoplamineto de tubo
85	00 68 440	1	Sks intelligent lubrication	Decal	Plaque d' identification	Adhesivo



Bild-Nr. Pos.-No. No.Pos. Pos.-No.	Bestell-Nr. Order-No. No. de Cde Ref.-Nr.	Menge Quantity Nombres Cantidad	Baugruppe Motoreinheit	Assembly Engine	Assemblage Moteur	Ensamblaje Motor
1	21 00 676	1	Motoreinheit enth. (-> 1 - 30	Engine incl. (-> 1 - 30	Moteur y inclus (-> 1 - 30	Motor incl. (-> 1 - 30
2	21 00 677	1	Kurbelgehäuse enth. (-> 2 - 5	Crankcase incl. (-> 2 - 5	Carter-moteur y inclus (-> 2 - 5	Carter cigüeñal incl. (-> 2 - 5
3	00 42 196 25	2	Huelse 7x10	Sleeve	Douille	Casquillo
4	60 11 430	1	Kurbelgehäuse Zünderseite	Crankhousing ignition side	Carter	Cárter de cigüeñal
5	60 11 431	1	Kurbelgehäuse Abtriebseite <-)	Crankhousing outlet side <-)	Carter <-)	Cárter de cigüeñal <-)
6	20 61 531	1	Dic. Kurbelgehäuse 0,5dick	Gasket crankcase	Joint de carter	Junta del cárter
7	00 50 102 1	1	Kug. Lag.15x35x11	Ball bearing	Roulement a billes	Cojinete de bolas
8	00 54 159	1	Wd. Ring15x24x7	Oil seal	Joint spy	Reten
9	00 50 202	1	Kug. Lag.17x40x12	Ball bearing	Roulement a billes	Cojinete de bolas
10	00 54 143	1	Wd. Ring17x28x5/5,5	Oil seal	Joint spy	Reten
11	22 00 684	1	Kurbelwelle	Crankshaft	Vilebrequin	Cigüeñal
12	00 18 339	5	Zyl. Shr.M5x30	F.h. screw	Vis	Tornillo
13	00 34 201	5	Si. Scheibe 5	Circlip	Rondelle crantee	Arandela
14	00 52 236	1	Nadelkäfig 12x16x13	Needle cage	Cage a aiguilles	Jaula de agujas
15	22 00 211	1	Zylinder + Kolben, Reparatursatz enth.: (-> 15 - 21	Cylinder + piston, repair kit incl. (-> 15 - 21	Cylindre + piston, kit de reparation y inclus (-> 15 - 21	Cilindro + pistón, juego de reparación incl. (-> 15 - 21
16	20 61 532	1	Dic. Zyl. Fuss	Cylinder foot gasket	Joint de cylindre	Junta del cilindro
17	22 00 212	1	Kolben Ø 52 mm enth. (-> 17 - 20	Piston incl. (-> 17, 20	Piston y inclus (-> 17, 20	Pistón incl. (-> 17, 20
18	20 31 233 25	1	Kolbenbolzen 12/8x32	Piston pin	Axe de piston	Bulon de pistón
19	20 48 258	2	Kolbenring 52x1,2	Piston ring	Anneau de piston	Clip
20	00 55 297	2	Si. Ring12x1,0 <-)	Safety ring <-)	Anneau de securite <-)	Anillo de pistón <-)
21	00 67 120 25	1	Impulsanschluss 5x17 <-)	Impulse connection <-)	Connecteur d'impulses <-)	Conexión de impulsos <-)
22	00 34 201	4	Si. Scheibe5	Circlip	Rondelle crantee	Arandela
23	00 10 604	4	Zyl. Shr.M5x22	Screw	Vis	Tornillo
24	28 00 881	1	Ventil Deko	Decompression valve	Soupape deko	Válvula de decompresión
25	23 00 730	1	Zuendkerze	Spark plug	Bougie d'allumage	Bujía
26	25 00 758	1	Auspuff enth. (-> 26 - 29	Exhaust incl. (-> 26 - 29	Echappement y inclus (-> 26 - 29	Escape incl. (-> 26 - 29
27	20 48 320	1	Funkenschutzsieb	Spark arrestor	Protection de etincelles	Proteccion de chispas
28	25 00 759	1	Funkenschutzblech	Spark aresstor screen	Plaque de protection	Tamiz de chispa
29	20 61 536	1	Auspuffdichtung <-)	Exhaust gasket <-)	Joint d' echappement <-)	Junta del escape <-)
30	00 18 336	1	Zyl. Shr. M5x16 <-)	Screw <-)	Vis crantee <-)	Tornillo <-)



Bild-Nr. Pos.-No. No.Pos. Pos.-No.	Bestell-Nr. Order-No. No. de Cde Ref.-Nr.	Menge Quantity Nombres Cantidad	<b>Baugruppe Starter</b>	<b>Assembly Starter</b>	<b>Assemblage Lanceur</b>	<b>Ensamblaje Arranque</b>
1	26 00 257	1	Starter enth. (-> 1 - 10	Starter incl. (-> 1 - 10	Lanceur y inclus (-> 1 - 10	Arranque incl. (-> 1 - 10
2	26 00 234	1	Startergehaeuse	Starter housing	Carter lanceur	Cárter de arranque
3	26 00 353	1	Rueckhofeder	Rewind spring	Ressort en arriere	Resorte retroceso
4	60 74 923	1	Seilrolle	Rope pulley	Poulie	Roldana
5	00 63 181	1	Starterseil 4x1300 beschichtet	Starter rope 4x1300	Corde de lanceur 4x1300	Cuerda de arranque 4x1300
6	20 74 640	1	Seilfuehrung	Rope guide	Guide de corde	Guia de cuerda
7	20 74 361	1	Startergriff gross	Starter grip	Poignée lanceur	Empuñadura arranque
8	00 31 473	1	Scheibe 15x21x0,5	Washer 15x21x0,5	Rondelle 15x21x0,5	Arandela 15x21x0,5
9	00 55 136	1	Si. Ring15	Circlip	Circlips ext.	Clip
10	00 68 459	1	Sks solo starter (-)	Decal starter (-)	Autocollant (-)	Adhesivo (-)



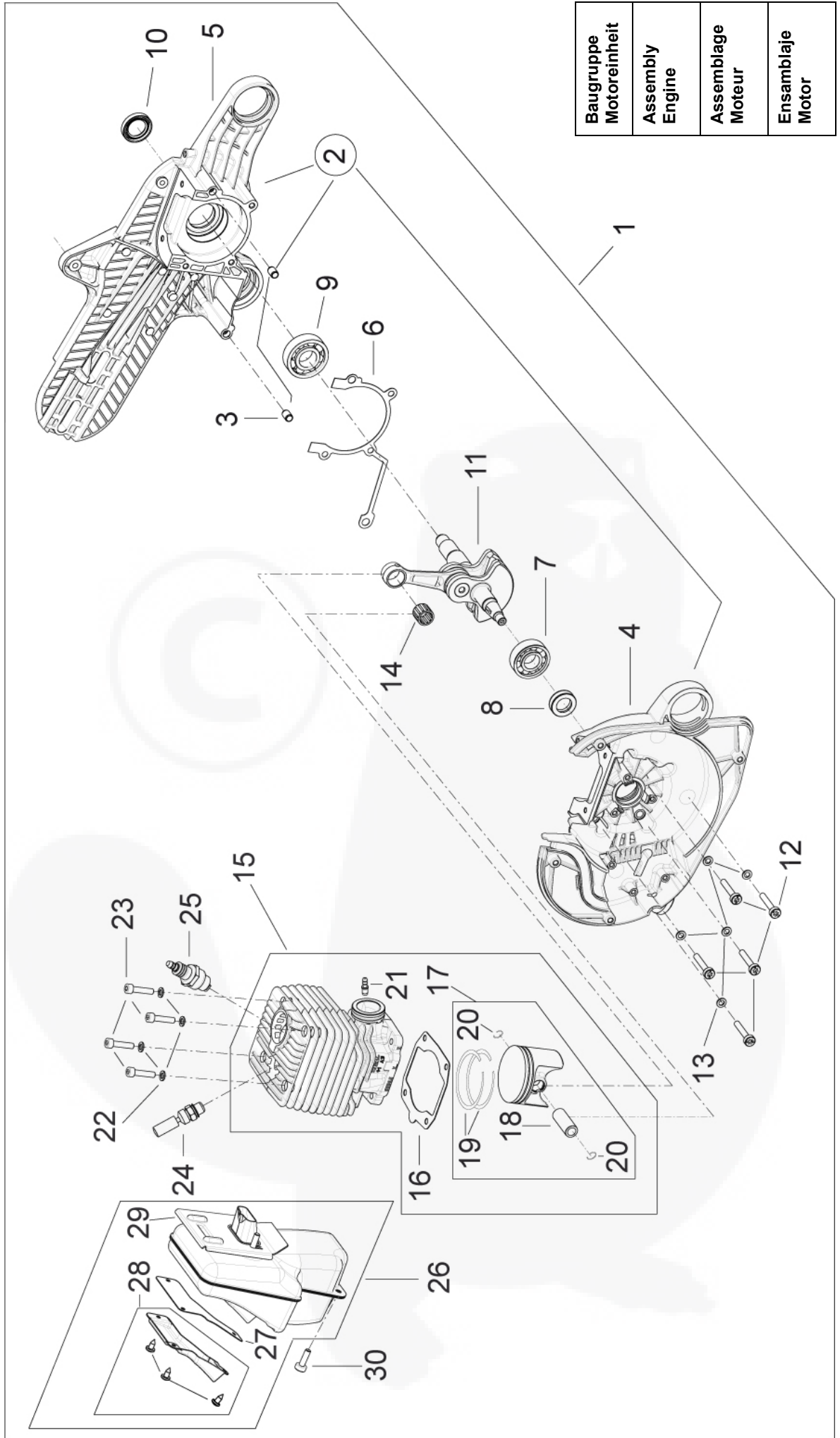

Bild-Nr. Pos.-No. No.Pos. Pos.-No.	Bestell-Nr. Order-No. No. de Cde Ref.-Nr.	Menge Quantity Nombres Cantidad	Baugruppe Antriebseinheit	Assembly Drive unit	Assemblage Unite de commande	Ensamblaje Unidad de mando
1	33 00 112	1	Antriebseinheit enth. (-> 1 - 30)	Drive unit incl. (-> 1 - 30)	Unite de commande y inclus (-> 1 - 30)	Unidad de mando incl. (-> 1 - 30)
2	20 11 861	1	Antriebseinheit	Drive unit carrier	Unite de commande	Tapa
3	00 12 259	2	6Kt. Shr. M8x35	Hex. Screw	Vis	Tornillo hex.
4	60 31 478	1	Lagerachse	Shaft bladedrive	Axe	Eje
5	00 50 151	2	Kug. Lag. 15x35x11	Ball bearing	Roulement a billes	Cojinete de bolas
6	00 33 302	1	Distanzrohr Kug. Lag.	Spacer ballbearing	Tube d' entretoise	Tubo espaciador
7	00 55 106	1	Si. Ring 35	Circlip 35	Circlips int. 35	Anillo de seguridad 35
8	60 11 436	1	Riemenscheibe 12" / 14"	Belt pulley 12" / 14"	Poulie de courroie 12"/14"	Polea para correa 12" / 14"
9	00 10 172	2	6Kt Kombi Schraube M8x18	Screw	Vis	Tornillo
10	00 31 442	2	Reibscheibe	Sliding disc	Rondelle	Arandela
11	80 74 755	2	Reibring	Slide ring	Anneau	Anillo
12	81 00 118	1	Schutzhaube 12"	Sa guard mg 12"	Couvercle de protection	Cubierta de protección
13	00 55 143	1	Si. Ring a20x1,2	Circlip	Circlips ext.	Anillo de seguridad
14	60 11 440	1	Druckring	Pressure ring	Anneau de pression	Anillo de presión
15	00 73 161	4	Feder Antriebseinheit	Spring blade-carrier	Ressort	Resorte
16	00 18 135	4	Schraube Antriebseinheit	Screw blade carrier	Vis	Tornillo
17	00 31 396	4	Scheibe 8x14x1,2	Washer	Rondelle 8x14x1.2	Arandela
18	20 16 459	2	Spannflansch	Clamping flange	Bride	Brida
19	60 74 804	1	Verstellgriff	Guard adjustment knob	Serrure	Cierre
20	00 18 337	2	Zyl. Shr. M5x20	F.h. screw	Vis torx	Tornillo
21	00 24 107	1	Hutmutter M5	Nut	Écrou	Tuerca
22	00 18 335	1	Zyl. Shr.M5x12	F.h. screw	Vis torx m5x12	Tornillo
23	00 68 460	2	Sks Schutzhaube 12"	Decal guard 12"	Autocollant	Adhesivo
24	00 68 454	1	Sks Vorsicht Schutz Rechts	Decal guard right	Autocollant	Adhesivo
25	00 68 453	1	Sks Vorsicht Schutz Llinks	Decal guard left	Autocollant	Adhesivo
26	00 65 321	0,350 m	Pu-Schlauch 6/4 mm schwarz	Hose 6/4 mm black	Tuyau 6/4 mm	Tubo 6/4 mm
27	00 65 321	0,200 m	Pu-Schlauch 6/4 mm schwar	Hose 6/4 mm black	Tuyau 6/4 mm	Tubo 6/4 mm
28	00 65 326	1	Schnellverschraubung gerade 1/4"x6/4	Screwing 1/4"x6/4	Raccord a vis 1/4"x6/4	Racor 1/4"x6/4
29	00 65 320	1	T-schnellverschraubung 1/8"x6/4	T-screwing 1/4"x6/4	Raccord a vis 1/4"x6/4	Racor 1/8"x6/4
30	00 65 322	1	L-schnellverschraubung 1/8"x6/4 (-)	T-screwing 1/4"x6/4 (-)	Raccord a vis 1/4"x6/4 (-)	Racor 1/8"x6/4 (-)

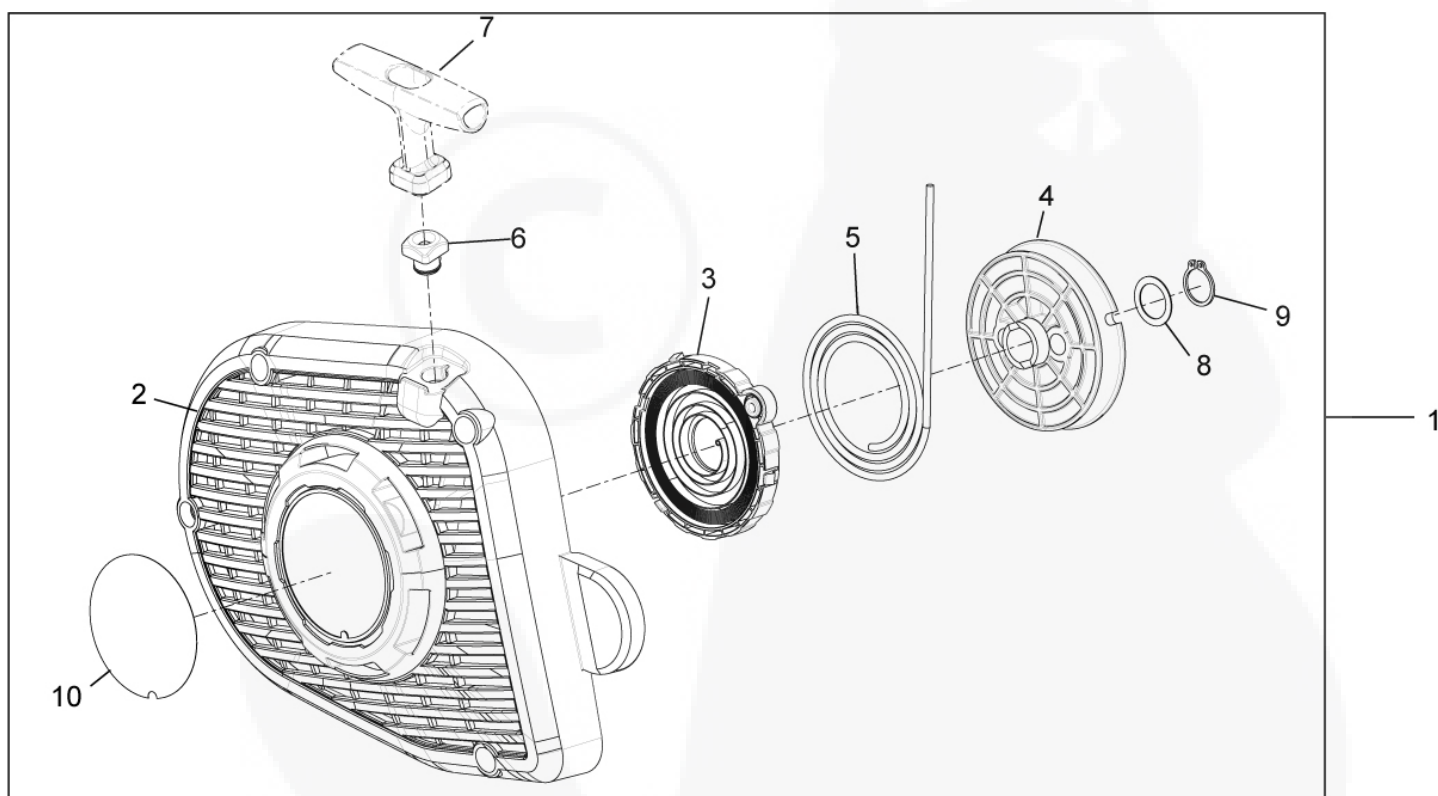

Bild-Nr. Pos.-No. No.Pos. Pos.-No.	Bestell-Nr. Order-No. No. de Cde Ref.-Nr.	Menge Quantity Nombres Cantidad	Baugruppe Griffeinheit	Assembly Grip	Assemblage Poignee	Ensamblaje Empuñadura
1	61 00 477	1	Griffeinheit enth. (-> 1 - 37)	Grip incl. (-> 1 - 37)	Poignee y inclus (-> 1 - 37)	Empuñadura incl. (-> 1 - 37)
2	61 00 315	1	Tankgehäuse	Tank housing	Carter reservoir	Carter del deposito
3	60 74 810	1	Gashebel	Throttle lever	Levier de gaz	Gatillo de gas
4	60 74 811	1	Sicherungshebel	Safety lever	Levier de securite	Palanca de seguridad
5	00 40 186	3	Stift 3 M6x24	Pin	Goupille	Perno
6	00 73 445	1	Schenklfeder	Spring throttle	Ressort	Resorte
7	60 73 706	1	Griffschale	Back handle cover	Capsule poignee	Tapa
8	68 00 167	1	Haltebügel	Handle bar	Etrier	Asa
13	00 18 377	2	Li. Shr.6x30	Screw	Vis parker	Tornillo
14	00 18 370	2	Li. Shr.6x20	Screw	Vis parker	Tornillo
15	20 11 767	1	Standfuss	Foot	Support	Soporte
16	60 63 294	2	Gummifuss	Rubber foot	Pied de gomme	Pie de goma
17	00 30 108	2	Scheibe5,3	Washer	Rondelle	Arandela
18	00 18 402	2	Zyl. Shr.10-24x18	F.h. screw	Vis t.c.	Tornillo
19	60 63 295	1	Gummifuss Griffgehäuse	Rubber foot	Pied de gomme	Pie de goma
20	00 21 215	2	4kt. Mutter M4	Square nut	Ecrou	Tuerca
21	00 72 148	2	Si. Scheibe 4	Disc spring	Rondelle de tension	Arandela
22	00 18 280	2	Zyl. Shr. M4x12	Screw	Vis	Tornillo
23	64 00 234	1	Ölpumpe	Oil pump	Pompe d' huile	Bomba de aceite
24	00 18 361	1	Li. Shr.5x12	Screw	Vis parker	Tornillo
25	00 28 156	4	Blechmutter M5	Speed nut m5	Ecrou m5	Tuerca m5
26	80 63 248	1	Tuelle3/8,5/10x2/6,8	Grommet	Passe fil	Boca
27	00 66 381	1	Winkelstützen3x12,5	Elbow	Raccord coude	Codo
28	00 64 484	110mm	Schlauch 2x1,5	Tube	Tuyau	Tubo
29	27 00 414	1	Belueftungsstützen	Ventilation socket	Soupape d'aeration	Válvula
30	80 74 744	1	Blende Rechts	Screen	Panneau	Tapa
31	80 74 745	1	Blende Links	Screen	Panneau	Tapa
32	00 66 335	1	Tuelle 6,5/9x2,2/6,2	Grommet	Passe fil	Boca
33	00 18 345	1	Zyl. Shr. M6x12	Screw	Vis	Tornillo
34	80 42 508	1	Befestigungsplatte	Plate	Plaque	Chapa
35	00 20 142	1	4kt. Mu. M6	Square nut	Ecrou	Tuerca
36	60 63 371	1	Kraftstoffschlauch	Fuel line	Tuyau d' essence	Tubo de gasolina
37	60 63 306	1	Oelschlauch (-)	Oil pipe (-)	Tuyau (-)	Tubo de conexion (-)

<b>Baugruppen</b>
Federlagerungen, Expansionskammer, Mittelkonsole, Haube, Wasseranschluss
<b>Assembly</b>
Support, Suction elbow, Console, Cover, Connection
<b>Assemblage</b>
Pied ressort, Coude d' aspiration, Console, Couvercle, Connection
<b>Ensamblaje</b>
Soporte, Codo de aspiración, Consola, Cubierta, Conexión

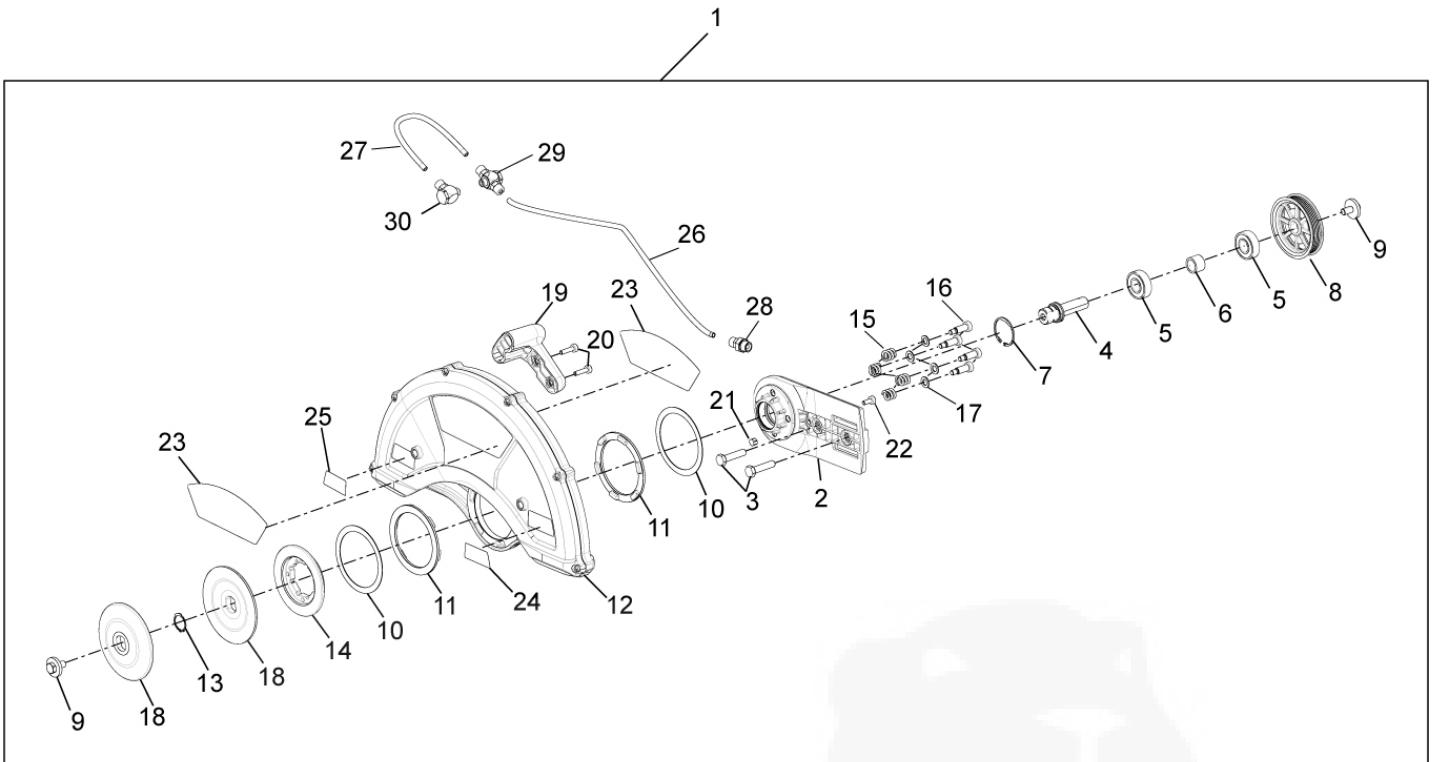

Bild-Nr. Pos.-No. No.Pos. Pos.-No.	Bestell-Nr. Order-No. No. de Cde Ref.-Nr.	Menge Quantity Nombres Cantidad	<b>Baugruppen Federlagerungen, Expansionskammer, Mittelkonsole, Haube, Wasseranschluss</b>	<b>Assembly Support, Suction elbow, Console, Cover, Connection</b>	<b>Assemblage Pied ressort, Coude d' aspiration, Console, Couvercle, Connection</b>	<b>Ensamblaje Soporte, Codo de aspiración, Consola, Cubierta, Conexión</b>
1	63 00 273	1	Federlagerung Fuß enth. (-> 1 - 4	Support incl. (-> 1 - 4	Pied ressort y inclus (-> 1 - 4	Soporte incl. (-> 1 - 4
2	00 73 269	1	Dämpfungsfeder	Spring avs	Ressort d' ammortisseur	Resorte av
3	00 15 111	1	Gewindeinsatz D23,5x7	Insert	Insert	Inserción
4	00 18 345	1	Zyl. Shr. M6x12 (-)	F.h. screw (-)	Vis (-)	Tornillo (-)
5	63 00 275	1	Federlagerung Haltebügel enth. (-> 5 - 11	Support incl. (-> 5 - 11	Support y inclus (-> 5 - 11	Soporte incl. (-> 5 - 11
6	00 73 269	1	Dämpfungsfeder	Spring avs	Ressort d' ammortisseur	Resorte av
7	00 18 347	1	Zyl. Shr.M6x20	F.h. screw	Vis	Tornillo
8	00 30 125	1	Scheibe6,4 9021-140hv zn	Washer	Rondelle a 6	Arandela
9	00 20 109	1	6kt. Mu. M8 934-8zn blau	Hex. Nut	Ecrou	Tuerca
10	60 74 831	1	Klemmstück innen	Clamp	Collier	Abrazadera
11	60 63 287	1	Faltenbalg (-)	Bellow rubber (-)	Soufflet d' intercircularion (-)	Fuelle (-)
12	63 00 274	3	Federlagerung Tankgehäuse enth. (-> 12 - 15	Spring support incl. (-> 12 - 15	Support de ressort y inclus (-> 12 - 15	Soporte de resorte incl. (-> 12 - 15
13	00 36 132	1	Federlagerung Abtriebs. Hinten	Spring seat	Bride de ressort formant palier	Apoyo del resorte
14	00 73 270	1	Dämpfungsfeder	Spring avs	Ressort	Resorte av
15	00 18 370	1	Li. Shr.6x20 (-)	Screw (-)	Vis parker 6x20 (-)	Tornillo (-)
16	23 00 871	1	Expansionskammer vollst. enth. (-> 16 - 20	Suction elbow incl. (-> 16 - 20	Coude d' aspiration y inclus (-> 16 - 20	Codo de aspiración incl. (-> 16 - 20
17	60 74 543	1	Expansionskammer	Chamber	Chambre	Camara
18	00 62 352	1	Moosgummiring 190	Foam rubber ring 190	Anneau de gomme 190	Anillo de goma 190
19	80 74 749	1	Kompensatorkammer	Compensator chamber	Chambre	Camara
20	00 18 354	1	Li. Shr.4x12 (-)	Lens head screw (-)	Vis parker (-)	Tornillo (-)
21	61 00 486	1	Mittelkonsole Vollst ilube enth. (-> 21 - 37	Console incl. (-> 21 - 37	Console y inclus (-> 21 - 37	Consola incl. (-> 21 - 37
22	60 73 707	1	Mittelkonsole	Console	Console	Consola
23	60 74 455	1	Reinigungsknopf	Cleaning knob	Bouton	Botton
24	60 74 454	1	Ratsche	Ratchet	Percoir a rochet	Trinquete
25	00 28 137	1	6kt. Mu. M5	Hex. Nut	Ecrou frein	Tuerca
26	00 18 335	1	Zyl. Shr. M5x12	F.h. screw	Vis	Tornillo
27	27 00 448	1	Primer	Primer	Primer	Cebador
28	00 84 514	1	Kabelbaum Mikroschalter ilube	Microswitch with cable ilube	Interrupteur	Interruptor
29	68 00 403	2	Feder Druckstück	Spring	Ressort	Resorte
30	60 74 456	1	Stop Knopf	Stop knob	Bouton	Boton
31	60 74 723	1	Drehschalter			Caja
32	00 73 163	1	Feder Stoptaster	Spring button stop	Ressort	Resorte
33	60 74 813	1	Halter Mikroschalter	Support	Support	Soporte
34	60 74 814	1	Umschalter	Switch	Interrupteur	Interruptor
35	00 28 156	4	Blechmutter M5	Speed nut m5	Ecrou m5	Tuerca m5
36	00 13 285	2	Li. Bl. Shr.3,5x9,5	Screw	Vis	Tornillo
37	00 68 457	1	Sks Filterreinigung (-)	Decal filter cleaning (-)	Autocollant (-)	Adhesivo (-)
38	61 00 240	1	Haube Trennschleifer vs enth. (-> 38 - 45	Cover incl. (-> 38 - 45	Couvercle y inclus (-> 38 - 45	Cubierta incl. (-> 38 - 45
39	60 73 698	1	Haube	Cover	Capot	Cubierta
40	60 74 717	1	Zündkerzenabdeckung	Spark plug cover	Couvercle de bougie	Tapa de bujía
41	00 18 335	1	Zyl. Shr.M5x12	F.h. screw	Vis	Tornillo
42	60 63 307	1	Abdeckung Dekoventil	Cover decovalve	Couvercle	Tapa
43	20 42 801	1	Hitzeschutzfolie	Protection foil	Feuille de protection	Laminilla de protección
44	00 68 448	1	Sks Warnung Haube	Decal top cover	Autocollant	Adhesivo
45	00 68 444	1	Sks Bedienungshinweise (-)	Sticker (-)	Autocollant (-)	Adhesivo de instrucción(-)
46	00 65 324	1	Zb. Wasseranschluss enth. (-> 46 - 52	Connection incl. (-> 46 - 52	Connection y inclus (-> 46 - 52	Conexion incl. (-> 46 - 52
47	00 65 323	1	Minikugelhahn 1/4" ig	Ball cock 1/4"	Robinet a boisseau sph. 1/4"	Llave de bola 1/4"
48	80 74 769	1	Anschlussstück Kugelhahn	Connection part	Piece de connection	Pieza de conexión
49	00 62 115	1	O. Ring 10x2nabr/perb 70sh.	O-ring	Joint torique	Anillo
50	40 74 922 25	1	Filtereinsatz	Filter cartridge	Insertion de filtre	Cartucho filtrante
51	80 74 768	1	Schlauchkupplung	Connection part	Piece de connection	Pieza de conexión
52	00 62 187	1	O. Ring 10,77x2,62 (-)	O-ring (-)	Joint bague (-)	Anillo o (-)

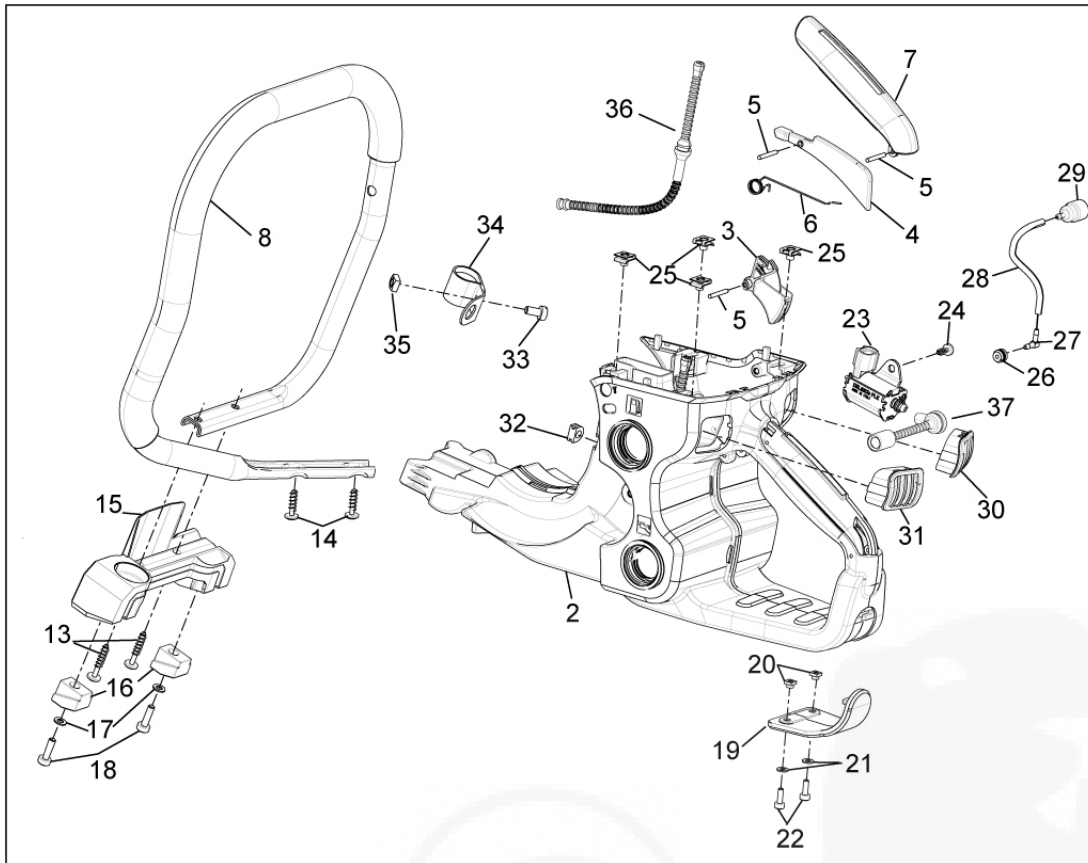

Bild-Nr. Pos.-No. No.Pos. Pos.-No.	Bestell-Nr. Order-No. No. de Cde Ref.-Nr.	Menge Quantity Nombres Cantidad	ET-SET „Erstausrüstung“	Spare part set "initial"	Pièces de rechange fixé « initiale »	Piezas de recambio establecer "inicial"
1	89 00 123	1	ET-SET „Erstausrüstung“ enth. (-> 1 - 15)	Spare part set "initial" incl. (-> 1 - 15)	Pièces de rechange fixé « initiale » y inclus (-> 1 - 15)	Piezas de recambio establecer "inicial" incl. (-> 1 - 15)
2	25 00 771	10	Siebeinsatz	Screen insert	Insertion de tamis	Insercion de tamiz
3	25 00 794	10	Luftfilter	Main filter	Filtro principal	Filtro principal
4	27 00 240	2	Tankverschluss Benzin	Tank lid	Fermeture reservoir	Tapa del depósito
5	27 00 135	2	Filter Benzin	Filter fuel pick-up	Fitre essence	Filtro gasolina
6	27 00 241	2	Tankverschluss Öl	Tank lid	Fermeture reservoir	Tapa del depósito
7	67 00 121	2	Oelsieb	Oil strainer	Tamis d'huile	Tamiz de aceite
8	23 00 730	2	Zuendkerze	Spark plug	Bougie d'allumage	Bujia
9	28 00 881	2	Ventil Deko	Decompression valve	Soupape deko	Valvula de decompression
10	35 00 470	2	Kupplung M12x11. Fliehkraft	Centrifugal clutch	Embrayage centrifuge	Embrague centrifugo
11	35 00 483	2	Kupplungsglocke	Clutch drum	Cloche embrayage	Campana embrague
12	00 57 114	2	Rippenband	Belt	Cinture	Correa
13	20 16 459	4	Spannflansch	Clamping flange	Bride	Arandela
14	00 10 172	2	6Kt Kombi Schraube M8x18	Screw	Vis	Tornillo
15	40 74 922 25	2	Filtereinsatz (-)	Filter cartridge (-)	Insertion de filtre (-)	Cartucho filtrante (-)

Bestell-Nr. Order-No. No. de Cde Ref.-Nr.	Menge Quantity Nombres Cantidad	Seite Page Page Pagina	Bestell-Nr. Order-No. No. de Cde Ref.-Nr.	Menge Quantity Nombres Cantidad	Seite Page Page Pagina	Bestell-Nr. Order-No. No. de Cde Ref.-Nr.	Menge Quantity Nombres Cantidad	Seite Page Page Pagina	Bestell-Nr. Order-No. No. de Cde Ref.-Nr.	Menge Quantity Nombres Cantidad	Seite Page Page Pagina
00 10 172	2	9, 13	00 50 102 1	1	6	20 16 459	2	9	60 42 850	1	2
00 10 264	1	4	00 50 151	2	9	20 16 459	4	13	60 43 137	1	2
00 10 362	1	2, 4	00 50 202	1	6	20 31 233 25	1	6	60 63 287	1	11
00 10 604	4	6	00 52 236	1	6	20 36 285	1	4	60 63 294	2	10
00 12 259	2	9	00 54 143	1	6	20 42 801	1	11	60 63 295	1	10
00 13 285	2	4, 11	00 54 159	1	6	20 48 258	2	6	60 63 306	1	10
00 13 287	3	2	00 55 106	1	9	20 48 320	2	6	60 63 307	1	11
00 15 111	1	11	00 55 136	1	8	20 61 444	1	4	60 63 324	1	2
00 18 135	4	9	00 55 143	1	9	20 61 531	1	6	60 63 371	1	10
00 18 274	4	4	00 55 161	1	2	20 61 532	1	6	60 73 540	1	2
00 18 280	2	10	00 55 297	2	6	20 61 536	1	6	60 73 541	1	2
00 18 327	3	2	00 57 114	1	2	20 74 361	1	8	60 73 698	1	11
00 18 334	1	2	00 57 114	2	13	20 74 640	1	8	60 73 706	1	10
00 18 335	4	4	00 62 115	1	11	21 00 676	1	2, 6	60 73 707	1	11
00 18 335	1	9	00 62 187	1	11	21 00 677	1	6	60 73 710	1	2
00 18 335	1	11	00 62 347	1	4	22 00 211	1	6	60 74 453	1	4
00 18 335	1	11	00 62 347	1	4	22 00 212	1	6	60 74 454	1	11
00 18 336	3	2	00 62 352	1	11	22 00 684	1	6	60 74 455	1	11
00 18 336	4	4	00 63 181	1	8	23 00 447	1	2	60 74 456	1	11
00 18 336	1	6	00 64 245	1	2	23 00 696	1	2	60 74 542	1	4
00 18 337	4	2	00 64 246	1	4	23 00 730	1	6	60 74 543	1	11
00 18 337	2	9	00 64 328	2	4	23 00 730	2	13	60 74 717	1	11
00 18 338	2	4	00 64 484	110mm	10	23 00 871	1	4, 11	60 74 723	1	11
00 18 339	5	6	00 65 320	1	9	23 00 872	1	4	60 74 804	1	9
00 18 345	1	10, 11	00 65 321	0,350 m	9	23 00 874	1	4	60 74 810	1	10
00 18 347	1	11	00 65 321	0,200 m	9	24 00 328	1	2	60 74 811	1	10
00 18 354	1	11	00 65 322	1	9	25 00 510	1	4	60 74 813	1	11
00 18 355	2	4	00 65 323	1	11	25 00 758	1	6	60 74 814	1	11
00 18 361	5	4	00 65 324	1	4, 11	25 00 759	1	6	60 74 831	1	11
00 18 361	1	10	00 65 325	1	4	25 00 771	1	4	60 74 832	1	4
00 18 370	2	10	00 65 326	1	9	25 00 771	10	13	60 74 870	1	4
00 18 370	1	11	00 66 335	2	2	25 00 793	1	4	60 74 923	1	8
00 18 377	2	10	00 66 335	1	10	25 00 794	10	4, 13	61 00 240	1	4, 11
00 18 389	2	4	00 66 381	1	10	25 00 795	20	4	61 00 315	1	10
00 18 402	2	10	00 66 429	1	4	26 00 234	1	8	61 00 338	1	2
00 18 455	2	4	00 66 678	2	2	26 00 257	1	2, 8	61 00 477	1	4, 10
00 18 460	3	2	00 67 120 25	1	6	26 00 353	1	8	61 00 486	1	4, 11
00 20 109	1	11	00 68 440	1	4	27 00 135	1	4	63 00 273	1	4, 11
00 20 142	1	10	00 68 444	1	11	27 00 135	2	13	63 00 274	3	4, 11
00 20 145	1	2	00 68 448	1	11	27 00 214	1	4	63 00 275	1	4, 11
00 21 215	2	10	00 68 453	1	9	27 00 240	1	4	64 00 234	1	10
00 24 106	2	2	00 68 454	1	9	27 00 240	2	13	67 00 121	1	4
00 24 107	1	9	00 68 457	1	11	27 00 241	1	4	67 00 121	2	13
00 28 137	1	11	00 68 459	1	8	27 00 241	2	13	68 00 167	1	10
00 28 156	4	4, 10	00 68 460	2	9	27 00 414	1	10	68 00 403	2	11
00 28 156	4	11	00 72 140	2	4	27 00 448	1	11	80 42 508	1	10
00 30 101	1	2	00 72 145	1	2	28 00 881	1	6	80 63 248	1	10
00 30 108	1	2	00 72 148	2	10	28 00 881	2	13	80 63 249	1	4
00 30 108	2	10	00 73 161	4	9	33 00 112	1	2, 9	80 74 744	1	10
00 30 125	1	11	00 73 163	1	11	35 00 470	1	2	80 74 745	1	10
00 31 396	4	9	00 73 269	1	11	35 00 470	2	13	80 74 746	1	4
00 31 442	2	9	00 73 269	1	11	35 00 483	1	2	80 74 747	1	4
00 31 473	1	8	00 73 270	1	11	35 00 483	2	13	80 74 749	1	11
00 33 302	1	9	00 73 445	1	10	40 74 922 25	1	11	80 74 755	2	9
00 33 429	1	2	00 73 451	1	2	40 74 922 25	2	13	80 74 768	1	11
00 34 152	2	4	00 75 101	1	2	60 11 430	1	6	80 74 769	1	11
00 34 201	5	6	00 80 112	1	2	60 11 431	1	6	80 74 772	1	4
00 34 201	4	6	00 84 514	1	11	60 11 436	1	9	81 00 118	1	9
00 36 132	1	11	00 84 515	1	4	60 11 440	1	9	89 00123	1	13
00 40 186	3	10	20 11 767	1	10	60 31 478	1	9			
00 42 196 25	2	6	20 11 861	1	9	60 31 810	1	2			

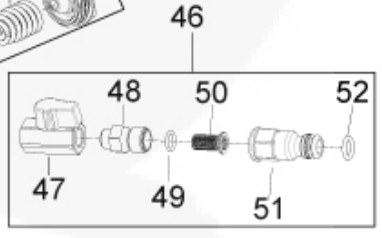
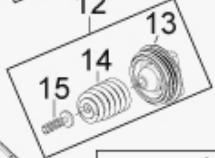
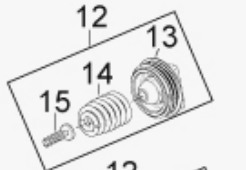
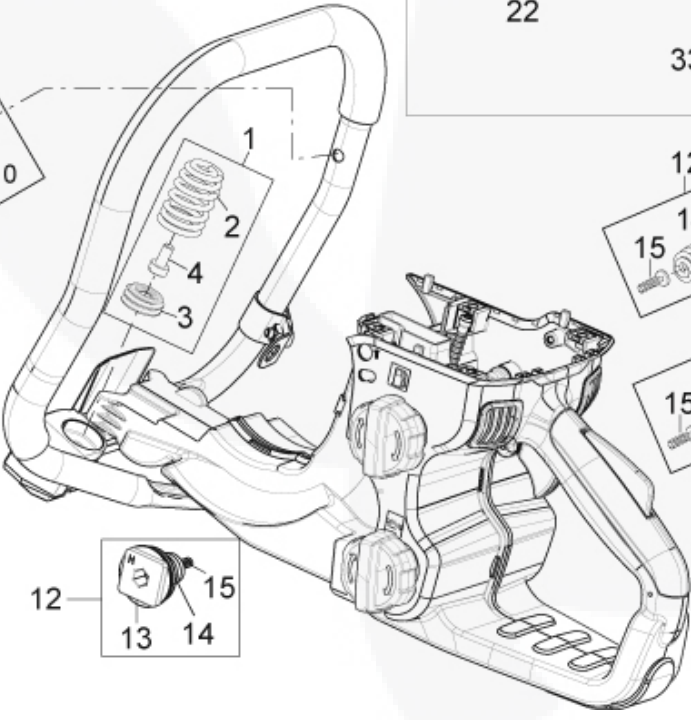
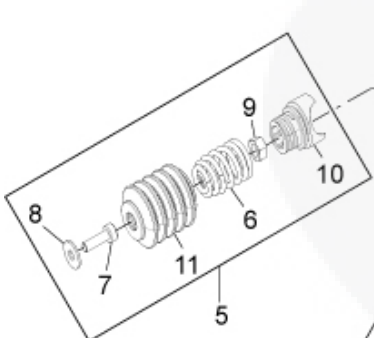
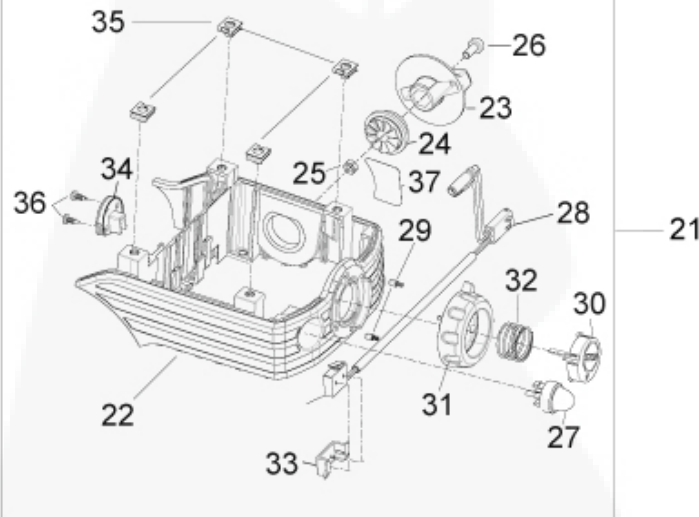
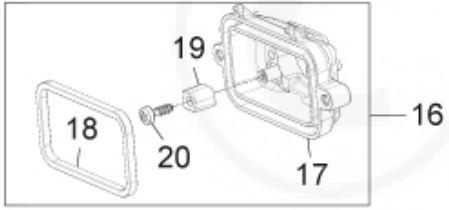
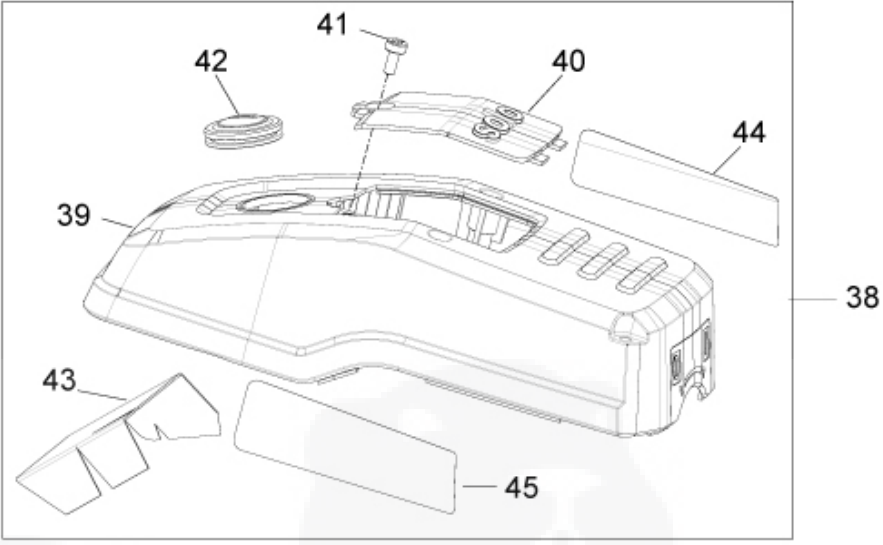
**D****Allgemeine Richtlinien für die Bestellung von Original SOLO Ersatzteilen:**

Voraussetzung für eine reibungslose Erledigung sind folgende Angaben:

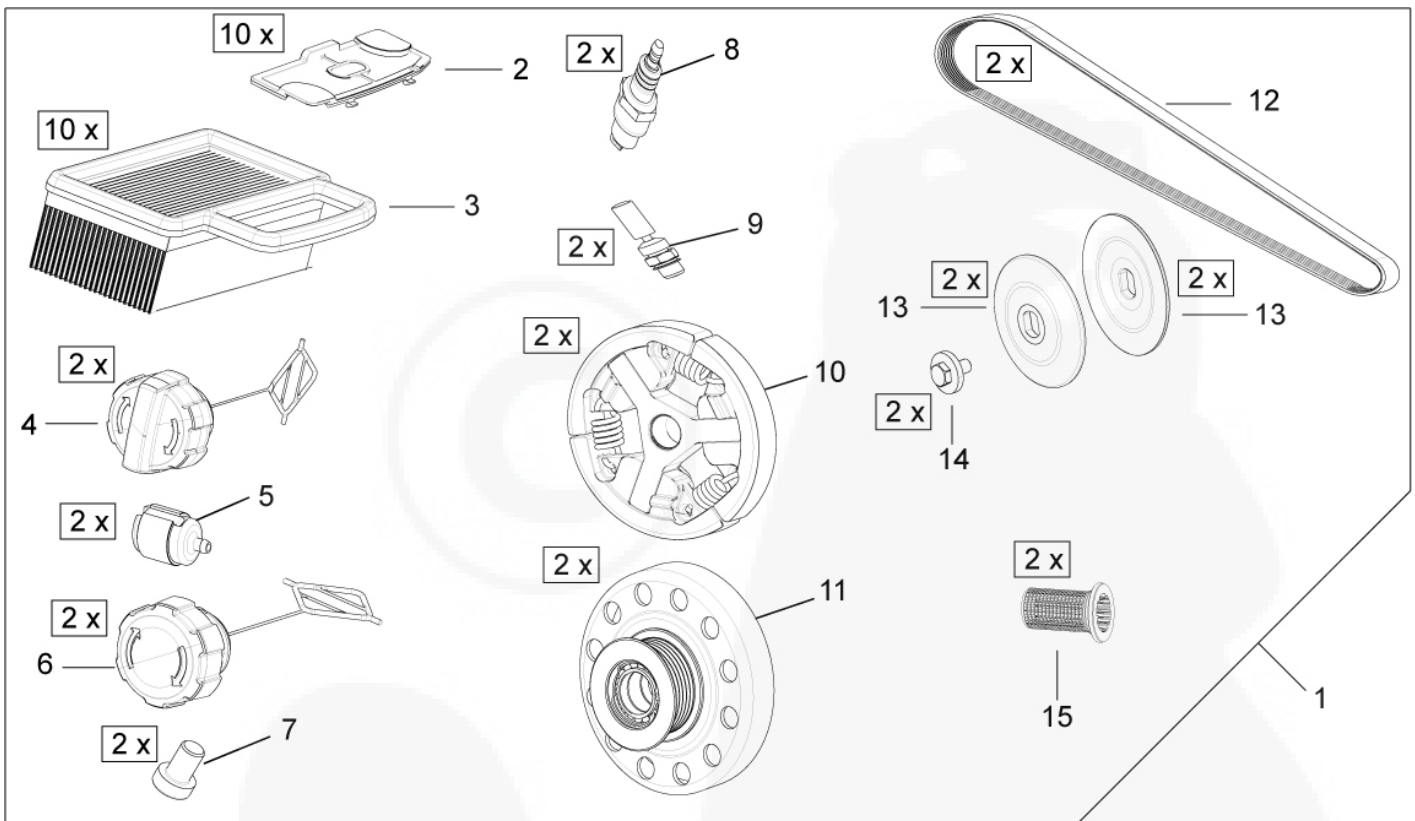
1. Ersatzteil-Bestellnummer
2. Gewünschte Anzahl
3. Typenbezeichnung des Geräts

Diese Ersatzteilliste ist für die Lieferung und Ausstattung von SOLO Erzeugnissen unverbindlich. Im Interesse der technischen Weiterentwicklung bleiben Konstruktionsänderungen vorbehalten.

**GB****General Directions for Ordering Original SOLO Spare Parts:**

For correct and diligent processing of your order, please give the following information:

1. Spare Part number
2. Quantity
3. Model and serial number
4. Shipping instructions

Delivery is made in accordance with our general sales and delivery conditions. This spare parts list is non-committal for us with regard to delivery and layout of SOLO products. In favour of technical improvements, design modifications are subject to change without notice.

**F****Directives générales pour les commandes de pièces de rechange d'origine SOLO:**

Il est indispensable de préciser dans toutes les commandes de pièces:

1. le numéro de référence de la pièce
2. la quantité
3. le type de la machine
4. le mode d'expédition

Les livraisons sont effectuées dans le cadre de nos conditions générales de vente. Toutes modifications réservées.

**E****Directivas Generales de pedido de la firma SOLO:**

Por adelantado de un arreglo sin dificultades necesitamos siguientes indicaciones:

1. Número de repuesto
2. Numero de cantidad
3. Modelo y número de serial
4. Instrucción de Envío

Esta lista de repuestos no es obligatoria para los envíos y/o forma de equipo de los productos SOLO. En el interés del constante desarrollo debemos reservarnos el derecho de cambios.