

Precision

LDT-1002 & LDT1002GY 10 Cu. Ft. Dump Cart

MODEL 2007

ASSEMBLY INSTRUCTIONS

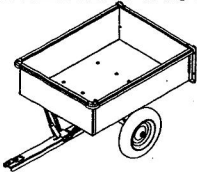

**Painted parts have two part numbers due to the two available colors for this model.

Tools Needed For Cart Assembly:

- Two - 7/16" Wrenches
- Two - 1/2" Wrenches
- One - 9/16" Wrench
- One - Pair Pliers
- One - Large Flat Blade Screw Driver

Parts List for the LDT-1002 & LDT1002GY

Ref. No	Parts No	Description	Qty	Ref. No	Parts No	Description
1	4562B	Body (Black)	1	10	1262	Cotter Pin
**	4562GY	Body (Gray)		11	1264	3/4" Flat Washer
2	4631B	Tow Bar (Black)	1	12	4468	1/4" x 2-3/4" Spacer
**	4631GY	Tow Bar (Gray)		13	1586	5/16" x 3/4" Truss Hd Bolt
3	4560B	Tailgate (Black)	1	14	4497	Spring
**	4560GY	Tailgate (Gray)		15	4552	3/8" x 3/4" Truss Head Bolt
4	4630B	Pedestal (Black)	1	16	1273	3/8" Hex Head Nut
**	4630GY	Pedestal (Gray)		17	1248	5/16" x 3/4" Hex Head Bolt
5	4556B	Undercarriage (Black)	1	18	1275	5/16" Hex Head Nut
**	4556GY	Undercarriage (Gray)		19	1274	3/8" Lock Washer
6	1243P	Clevis (Black)	1	20	1276	5/16" Lock Washer
**	1243GY	Clevis (Gray)		21	4466	1/4" x 3-1/2" HH Bolt
7	1265P	Latch (Black)	1	22	1558	1/4" Lock Nut
**	1265GY	Latch (Gray)		23	1817	1/4" Flat Washer
8	1252	Axle	1	24	1840	1/2" x 1-3/4" Clevis Pin
9	4559	Wheel	2	25	1042	#14 Hitch Pin Clip

1.) Insert 1/4" Spacer (12) through Spring (14) and the hole at bottom of Latch (7). Be sure Spring is attached to Latch as shown. Push Latch down through slot in Tow Bar (2) as shown. **NOTE: Grab the Latch Handle from the other side of the Tow Bar and pull down to align the Spacer with the holes in the sides of the Tow Bar.** Slide 1/4" x 3-1/2" Bolt (21) through side of Tow Bar, Washer (23), Spacer, Washer (23), and other side of Tow Bar. Secure with 1/4" Lock Nut (22).

Attach the Clevis (6) to the Tow Bar using 5/16" x 3/4" Hex Head Bolts (17), 5/16" Lock Washers (20) and 5/16" Hex Head Nuts (18). Insert the 1/2" x 1-3/4" Clevis Pin (24) through the large hole in the Clevis and Tow Bar. Secure the Clevis Pin by inserting the #14 Hitch Pin Clip (25) through the small hole on the end.

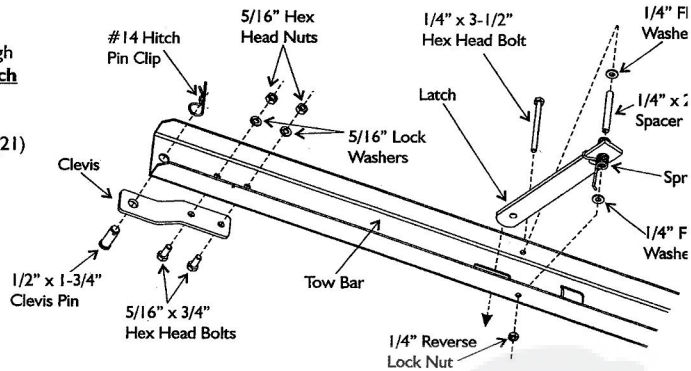

2.) Attach Undercarriage Axle Support (5) on bottom of Body (1). Use 3/8" x 3/4" Truss Head Bolts (15), 3/8" Lock Washers (19), and secure with 3/8" Hex Head Nuts (16).

Bolt the Pedestal (4) at front of Body with 5/16" x 3/4" Truss Head Bolts (13) from inside. On the outside, use 5/16" Lock Washers (20) and secure with 5/16" Hex Head Nuts (18).

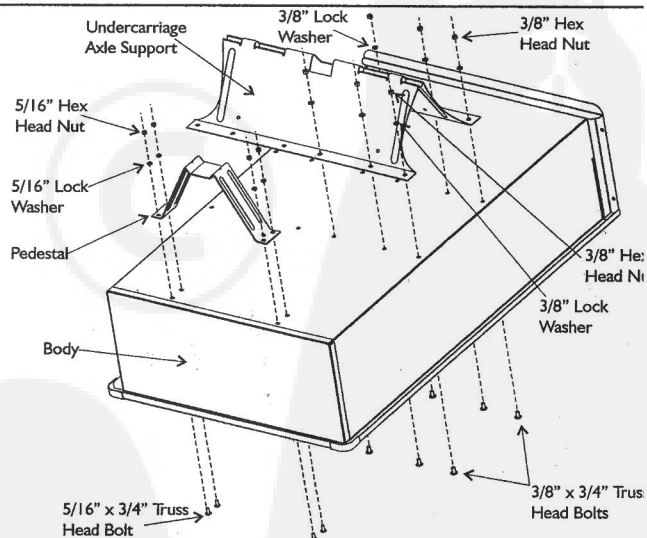

LDT1002 & LDT1002GY ASSEMBLY INSTRUCTIONS Continued

3.) Slide the Axle (8) halfway through the Undercarriage Axle Support. Next, insert the Axle through both holes in the end of the Tow Bar and on through the other side of the Undercarriage Axle Support. Connect the Tow Bar to the Pedestal using the Tow Bar Latch.

Place a 3/4" Flat Washer (11) over the Axle up against the Undercarriage Axle Support. Next, place a Wheel (9) onto the Axle. Place another 3/4" Flat Washer (11) over the Axle and secure the Wheel into place by inserting the Cotter Pin (10) through the hole in the end the Axle and spreading the legs of the Cotter Pin outward. Repeat the Wheel attachment step for the other wheel.

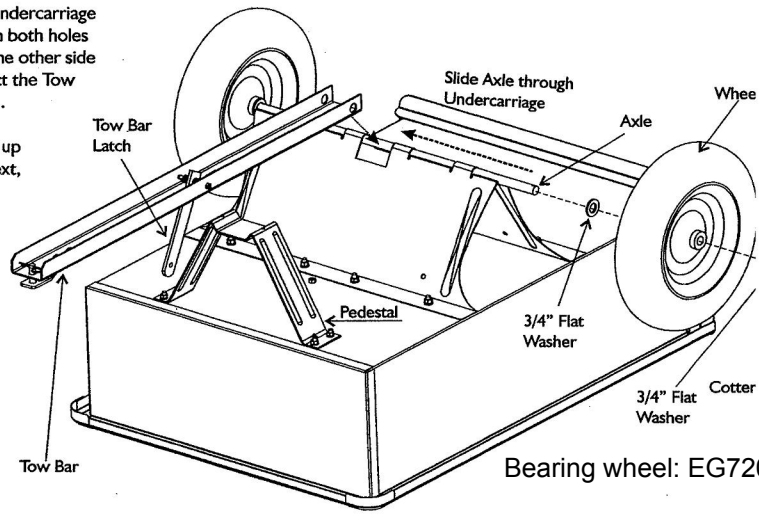

Bearing wheel: EG720-6638

OPERATION

TO DUMP - Pull latch toward mower and Cart Body will tilt back to dump position.
TO RETURN TO PULLING POSITION - Push down on front edge of Cart Body until Latch engages and secures to Tow Bar.
Tractor speed should be governed by weight of load. The heavier the load, the slower the speed for safe operation.

MAINTENANCE

Grease Wheels at regular intervals, at least every six months, more frequently if used regularly.
Check tire pressure at regular intervals.
Proper inflation will prolong life of tire.

NOTE:

650 Lbs. Maximum Capacity
Approximate weight (1) Cu. Ft.
DIRT-150# SAND-125# GRAVEL-110#
Max. Speed 4 MPH

WARNING OF DANGER OF IMPROPER USE OF THIS TRAILER CART. THIS UNIT IS INTENDED FOR USE ONLY WITH RIDING MOWERS OR GARDEN TRACTORS. IT IS DEFINITELY NOT FOR HIGHWAY USE, BEING PULLED AT HIGH SPEEDS, OR TRANSPORTING PASSENGERS OF ANY SORT. SUCH USE COULD RESULT IN INJURIES FOR WHICH WE CANNOT BE HELD RESPONSIBLE.

LIMITED WARRANTY

This unit is warranted against defects in materials and workmanship to the original purchaser, under normal use and service for a period of ninety (90) days from the date of sale. During the Warranty Period, we will repair or replace, at our option, free of charge to the original purchaser, any part of the unit that our examination shows to be defective in workmanship or materials.
This Warranty does not apply to damage in transit or damage caused by misuse, abuse, neglect, normal wear, or alterations by unauthorized persons.

CUSTOMER SUPPORT

At Precision Products, Inc. delivering quality, value and outstanding service is our goal. However, sometimes parts do become damaged or lost during transport from our facilities to the store. **If you have any problems, please do not return this merchandise to the store. Call us and we will take care of any problem you may have with this unit.**

When ordering replacement parts, please have the model number, part description and part number available.

Send To: Precision Products, Inc.
316 Limit Street
Lincoln, IL 62656
Toll Free (800) 225-5891 Ext. #20
Phone (217) 735-1590
Fax (217) 735-2435

Visit us on the web: www.precisionprodinc.co

Latch Handle Assembly Instructions

Tools Needed For Latch Assembly

Two - 7/16" Wrenches

Step 1

Slide Spring over the Latch Handle as shown below.

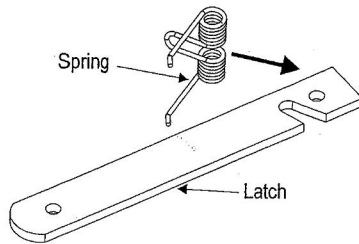

Step 2

Slide the 1/4" x 2-3/4" Spacer through the Spring and Latch as shown below.

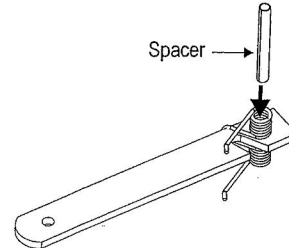

Step 3

Slide the Latch, Spring and Spacer through the Tow Bar. This will cause the Spring to open.

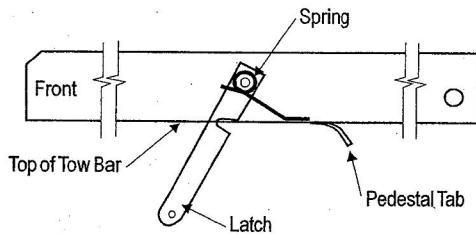

Step 4

Slide a 1/4" Flat Washer on each side of the Spacer.

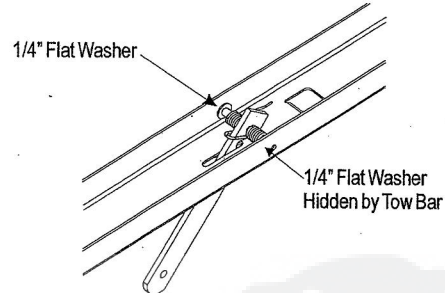

Step 5

Slide a 1/4" x 2-3/4" Hex Head Bolt through the Washers and Spacer and secure with a 1/4" Nylon Lock Nut.

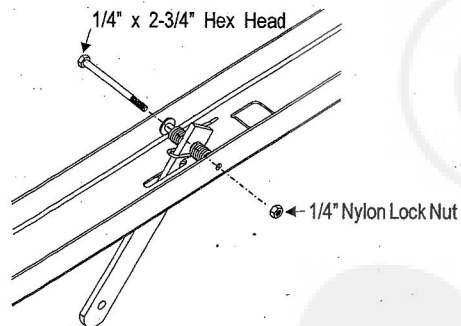

Finish

If assembled correctly the latch should be forced toward the back of the Tow Bar by the spring.

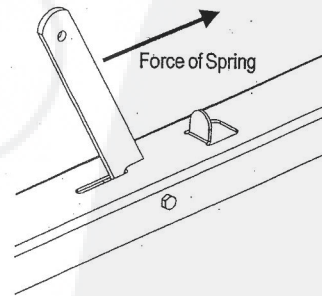

Manufactured by Precision Products Inc., 316 Limit St., Lincoln, Illinois 62656 U.S.A.

#####

06/06
Rev.1

Precision